

Bosch BOVA Split System Heat Pump

Condensing Units Up to 18 SEER

2-3-4-5 Ton Capacity

R410A



BOSCH

Installation Instructions



Table of Contents

1	Key to symbols and safety instructions	4
2	Unit location considerations	6
3	Unit preparation	8
4	Setting the unit	8
5	Refrigerant line considerations	9
6	Refrigerant line routing	10
7	Refrigerant line brazing	11
8	Refrigerant line leak check	13
9	Evacuation	13
10	Service valves	14
11	Electrical - low voltage	15
12	Electrical - high voltage	16
13	Start up	17
14	System charge adjustment	18
15	System operation and troubleshooting	21

1 Key to symbols and safety instructions

1.1 Key to symbols

Warnings



Warnings in this document are identified by a warning triangle printed against a grey background. Keywords at the start of a warning indicate the type and seriousness of the ensuing risk if measures to prevent the risk are not taken.

The following keywords are defined and can be used in this document:

- ▶ **DANGER** indicates a hazardous situation which, if not avoided, will result in death or serious injury.
- ▶ **WARNING** indicates a hazardous situation which, if not avoided, could result in death or serious injury.
- ▶ **CAUTION** indicates a hazardous situation which, if not avoided, could result in minor to moderate injury.
- ▶ **NOTICE** is used to address practices not related to personal injury.

Important information



This symbol indicates important information where there is no risk to people or property.

1.2 Safety

Please read before proceeding



CAUTION:

- ▶ This document is customer property and is to remain with this unit. Please return to service information pack upon completion of work.
- ▶ These instructions do not cover all variations in systems or provide for every possible contingency to be met in connection with the installation.
- ▶ Should further information be desired or should particular problems arise which are not covered sufficiently for the purchaser's purposes, the matter should be referred to your installing dealer or local distributor.



The manufacturer recommends installing only approved matched indoor and outdoor systems. All of the manufacturer's split systems are A.H.R.I. rated only with TXV indoor systems. Some of the benefits of installing approved matched indoor and outdoor split systems are maximum efficiency, optimum performance and the best overall system reliability.



This document contains a wiring diagram and service information. This is customer property and is to remain with this unit. Please return to service information pack upon completion of work.



CAUTION:

- ▶ This information is intended for use by individuals possessing adequate backgrounds of electrical and mechanical experience. Any attempt to repair a central air conditioning product may result in personal injury and/or property damage.



WARNING: HAZARDOUS VOLTAGE

- ▶ Failure to follow this warning could result in property damage, severe personal injury, or death.
- ▶ Disconnect all electric power, including remote disconnects before servicing. Follow proper lockout/tagout procedures to ensure the power cannot be inadvertently energized.

**WARNING: REFRIGERANT OIL**

- ▶ Any attempt to repair a central air conditioning product may result in property damage, severe personal injury, or death. These units use R-410A refrigerant which operates at 50 to 70% higher pressures than R-22. Use only R-410A approved service equipment. Refrigerant cylinders are painted a "Rose" color to indicate the type of refrigerant and may contain a "dip" tube to allow for charging of liquid refrigerant into the system. All R-410A systems with variable speed compressors use a PVE oil that readily absorbs moisture from the atmosphere. To limit this "hygroscopic" action, the system should remain sealed whenever possible. If a system has been open to the atmosphere for more than 4 hours, the compressor oil must be replaced. Never break a vacuum with air and always change the driers when opening the system for component replacement.

**WARNING: SERVICE VALVES**

- ▶ Failure to follow this warning will result in abrupt release of system charge and may result in personal injury and/or property damage. Extreme caution should be exercised when opening the Liquid Line Service valve. Turn valve stem counterclockwise only until the stem contacts the rolled edge. No torque is required.

**WARNING: BRAZING REQUIRED**

- ▶ Failure to inspect lines or use proper service tools may result in equipment damage or personal injury. If using existing refrigerant lines make certain that all joints are brazed, not soldered.

**CAUTION: HOT SURFACE**

- ▶ May cause minor to severe burning. Failure to follow this Caution could result in property damage or personal injury. Do not touch top of compressor.

**WARNING: HIGH CURRENT LEAKAGE**

- ▶ Failure to follow this warning could result in property damage, severe personal injury, or death. Grounding is essential before connecting electrical supply.

**CAUTION: CONTAINS REFRIGERANT**

- ▶ Failure to follow proper procedures can result in personal illness or injury or severe equipment damage. System contains oil and refrigerant under high pressure. Recover refrigerant to relieve pressure before opening system.

**CAUTION: GROUNDING REQUIRED**

- ▶ Failure to inspect or use proper service tools may result in equipment damage or personal injury. Reconnect all grounding devices. All parts of this product that are capable of conducting electrical current are grounded. If grounding wires, screws, straps, clips, nuts, or washers used to complete a path to ground are removed for service, they must be returned to their original position and properly fastened.

**CAUTION: INDOOR UNIT REQUIRED**

- ▶ The indoor units must be matched with TXV. The model of TXV can be changed according to the system capacity.

2 Unit location considerations

2.1 Unit dimensions

Unit Dimensions	
Models	H x W x L (Inches)
BOVA-36	24-15/16 x 29-1/8 x 29-1/8
BOVA-60	33-3/16 x 29-1/8 x 29-1/8

Table 1

The unit's weight values is on the carton box.

When mounting the outdoor unit on a roof, be sure the roof will support the unit's weight. Properly selected isolation is recommended to prevent sound or vibration transmission to the building structure.

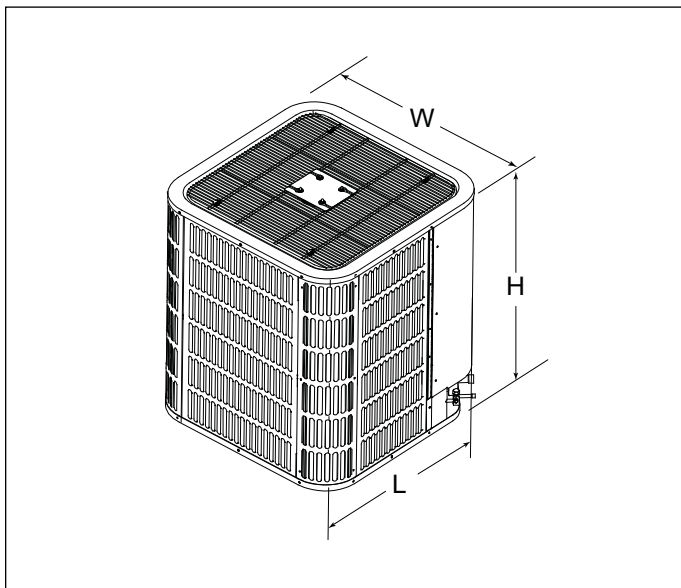

Figure 1

2.2 Refrigerant piping limits

- ▶ Maximum line equivalent length = 100 feet.
- ▶ Maximum vertical equivalent length = 50 feet.
- ▶ Use only the line diameters indicated in Table 5.1.
- ▶ If the suction line sets are greater than 60 feet do not use a larger suction line than recommended.

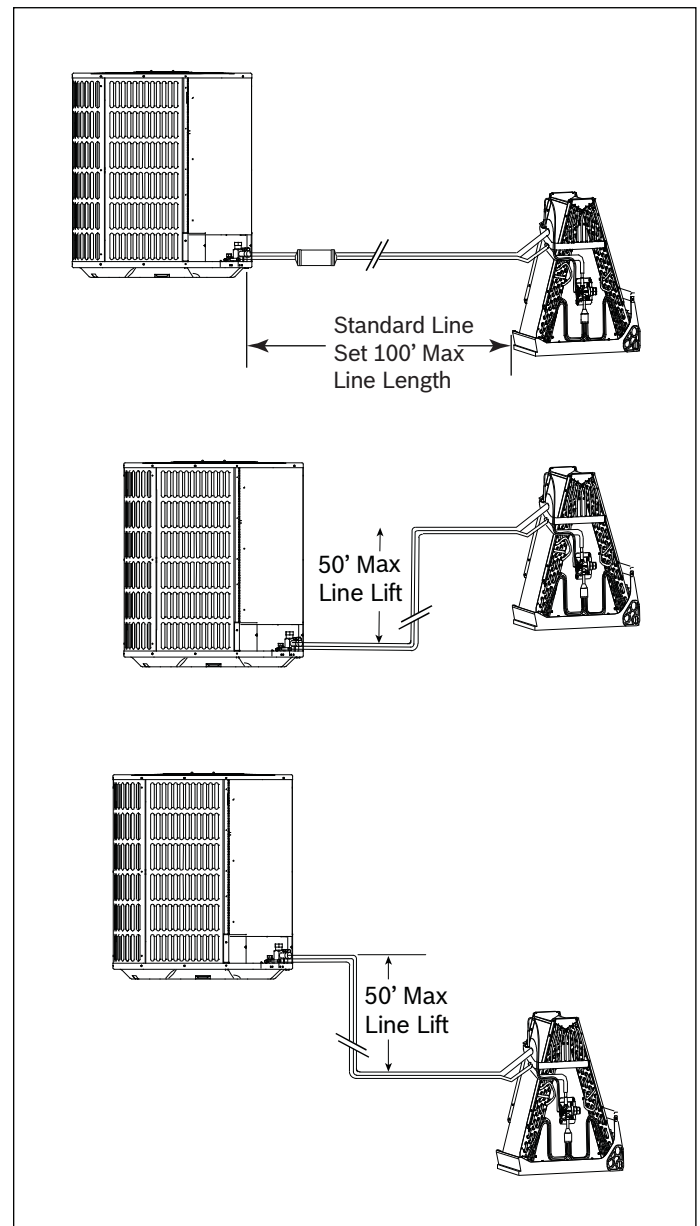

Figure 2

2.3 Location restrictions

Ensure the top discharge area is unrestricted for at least 60 inches above the unit.

Do not locate outdoor unit near bedrooms since normal operational sounds may be objectionable.

Position unit to allow adequate space for unobstructed airflow, wiring, refrigerant lines, and serviceability.

Allow a minimum of 12 in. clearance on one side of access panel to a wall and a minimum of 24 in. on the adjacent side of access panel.

Maintain a distance of 24 in. between units.

Position unit so water, snow, or ice from roof or overhang cannot fall directly on unit.

See Fig. 3 and Fig. 4.

Cold climate considerations (heat pump only)



Precautions must be taken for units being installed in areas where snow accumulation and prolonged below-freezing temperatures occur.

- ▶ Units should be elevated 3-12 inches above the pad or rooftop, depending on local weather. This additional height will allow drainage of snow and ice melted during defrost cycle prior to its refreezing. Ensure that drain holes in unit base pan are not obstructed, preventing drainage of defrost water (Fig. 5).
- ▶ If possible, avoid locations that are likely to accumulate snow drifts. If not possible, a snow drift barrier should be installed around the unit to prevent a build-up of snow on the sides of the unit.

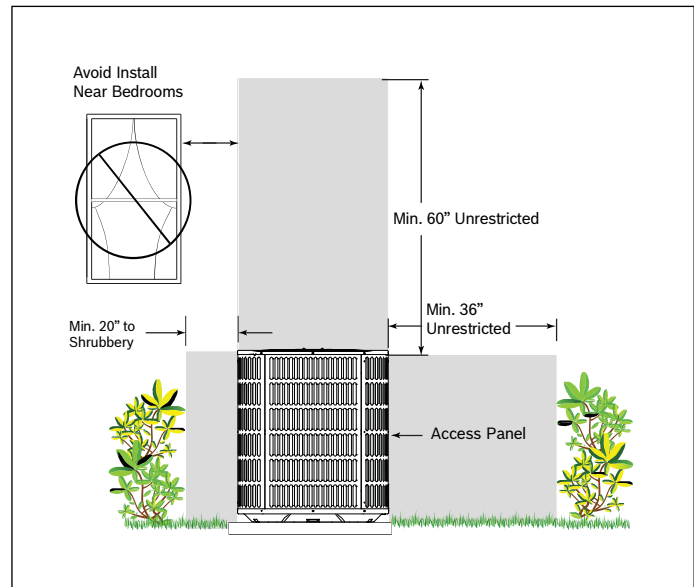

Figure 3

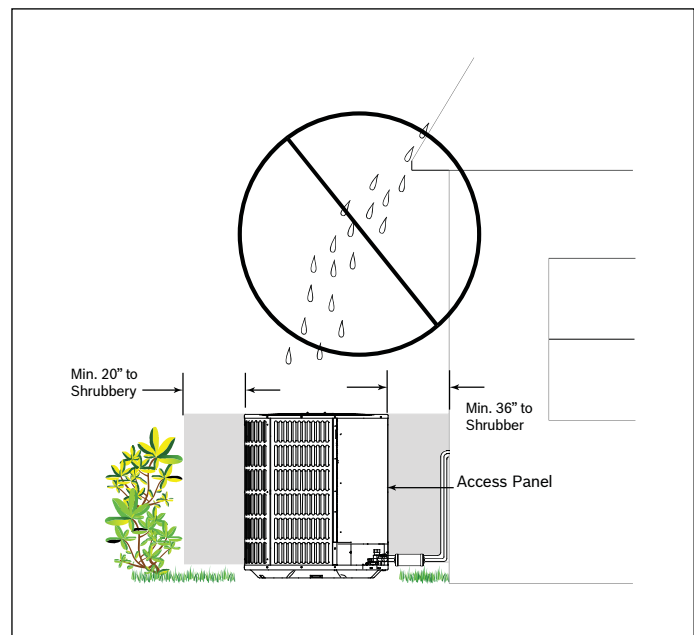

Figure 4

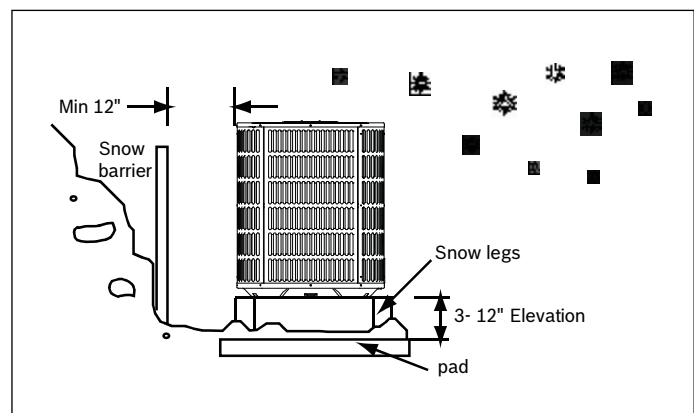

Figure 5

3 Unit preparation

3.1 Prepare the unit for installation

- ▶ STEP 1 - Check for damage and report promptly to the carrier any damage found to the unit (Fig. 6).
- ▶ The charge port can be used to check to be sure the refrigerant charge has been retained during shipment.

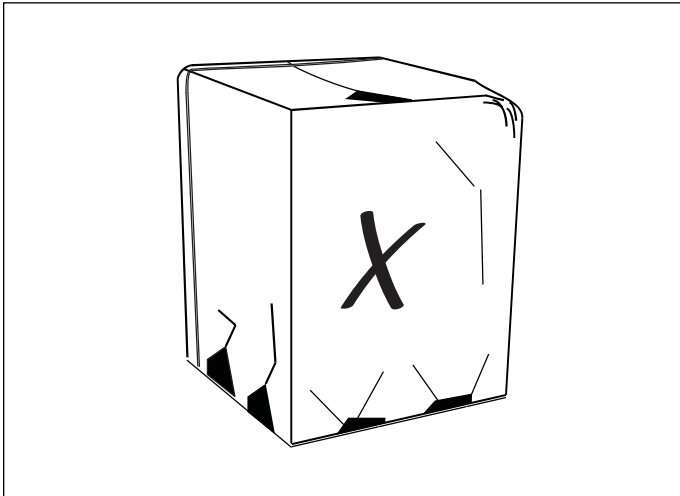

Figure 6

4 Setting the unit

4.1 Pad installation

When installing the unit on a support pad, such as a concrete slab, consider the following:

- ▶ The pad must be at least 1-2" larger than the unit on all sides.
- ▶ The pad must be separate from any structure.
- ▶ The pad must be level.
- ▶ The pad must be high enough above grade to allow for drainage.
- ▶ The pad location must comply with National, State, and Local codes.



These instructions are intended to provide a method to tie-down system to cement slab as a securing procedure for high wind areas. Check Local Codes for tie-down methods and protocols.

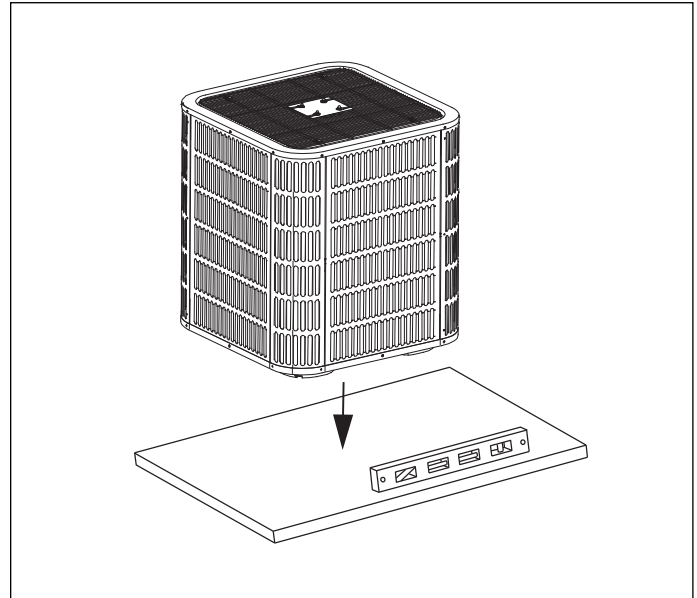

Figure 7

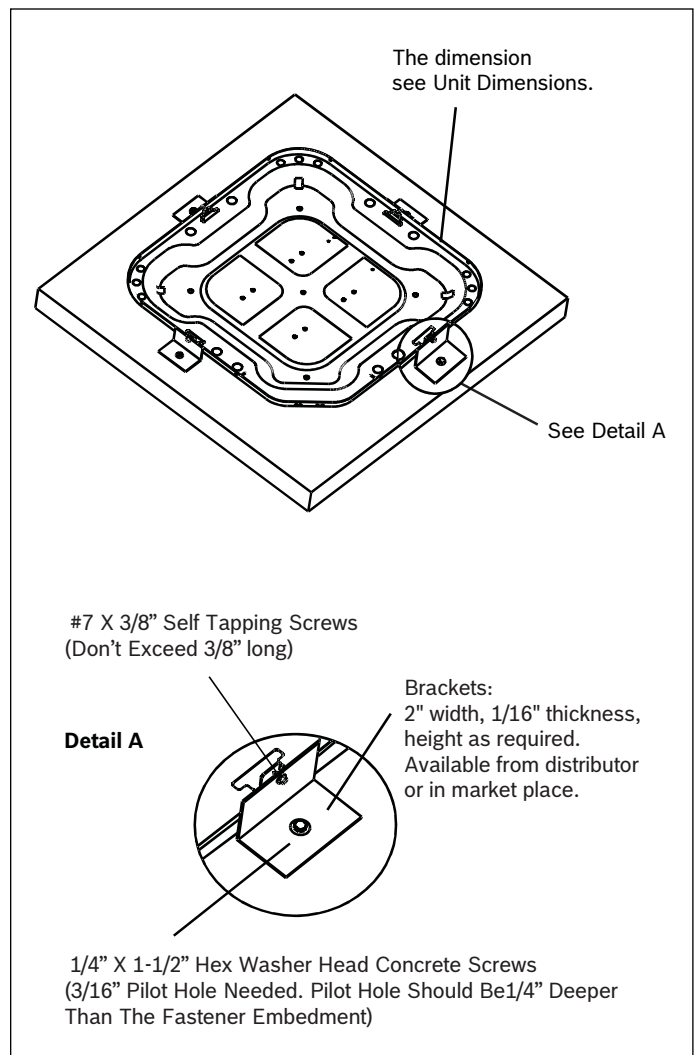

Figure 8

5 Refrigerant line considerations

5.1 Refrigerant line and service valve connection sizes

Models	Suction line	Liquid line	Suction line connection	Liquid line connection
BOVA-36	3/4	3/8	3/4	3/8
BOVA-60	7/8	3/8	7/8	3/8

Table 2

5.2 Required refrigerant line length

Determine required line length (Fig. 9).

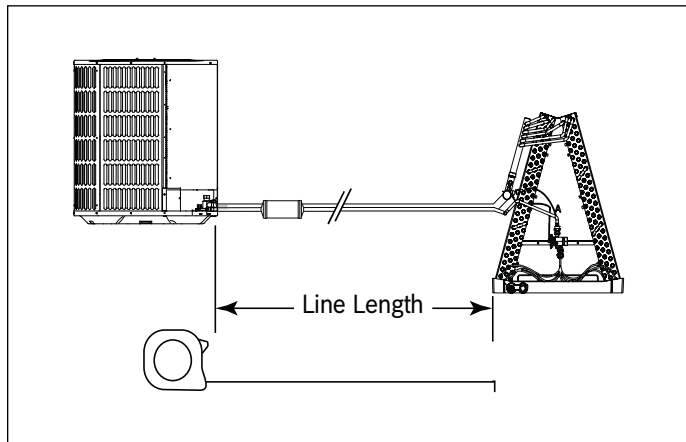

Figure 9

5.3 Refrigerant line insulation

i The Suction Line must always be insulated. DO NOT allow the Liquid Line and Suction Line to come in direct (metal to metal) contact.

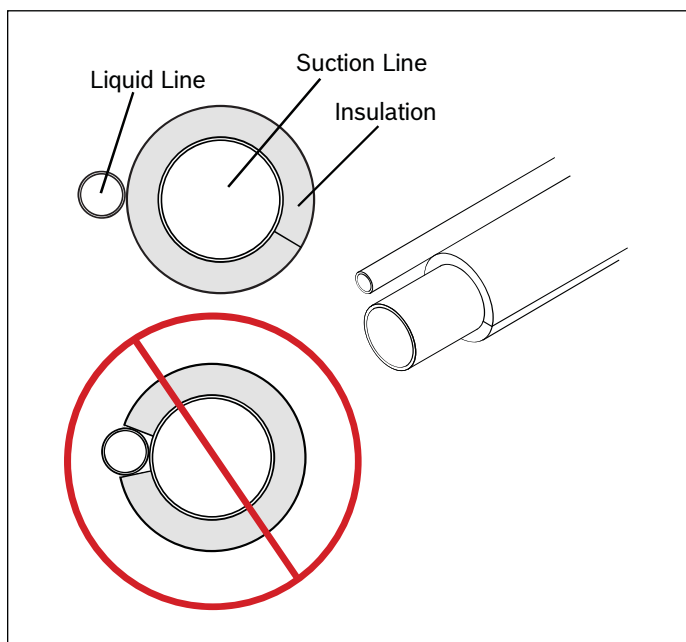

Figure 10

5.4 Reuse existing refrigerant lines



CAUTION:

- ▶ If using existing refrigerant lines make certain that all joints are brazed, not soldered.

For retrofit applications, where the existing refrigerant lines will be used, the following precautions should be taken:

- ▶ Ensure that the refrigerant lines are the correct size. Refer to Section 5.1 listed and Table 2.
- ▶ Ensure that the refrigerant lines are free of leaks, acid, and oil.



The manufacturer recommends installing only approved matched indoor and outdoor systems. All of the manufacturer's split systems are A.H.R.I. rated only with TXV indoor systems. Some of the benefits of installing approved matched indoor and outdoor split systems are maximum efficiency, optimum performance and the best overall system reliability.

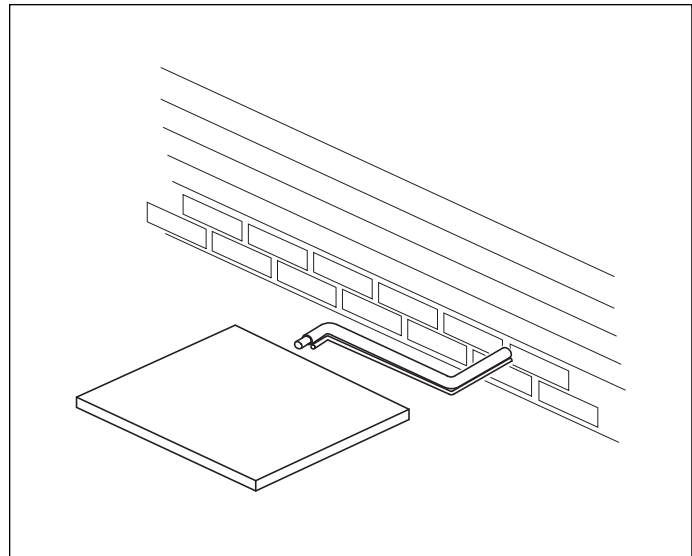

Figure 11

6 Refrigerant line routing

6.1 Precautions



Take precautions to prevent noise within the building structure due to vibration transmission from the refrigerant lines. For Example:

- ▶ When the refrigerant lines have to be fastened to floor joists or other framing in a structure, use isolation type hangers.
- ▶ Isolation hangers should also be used when refrigerant lines are run in stud spaces or enclosed ceilings.
- ▶ Where the refrigerant lines run through a wall or sill, they should be insulated and isolated.
- ▶ Isolate the lines from all ductwork.
- ▶ Minimize the number of 90° turns.



Comply with National, State, and Local Codes when isolating line sets from joists, rafters, walls, or other structural elements.

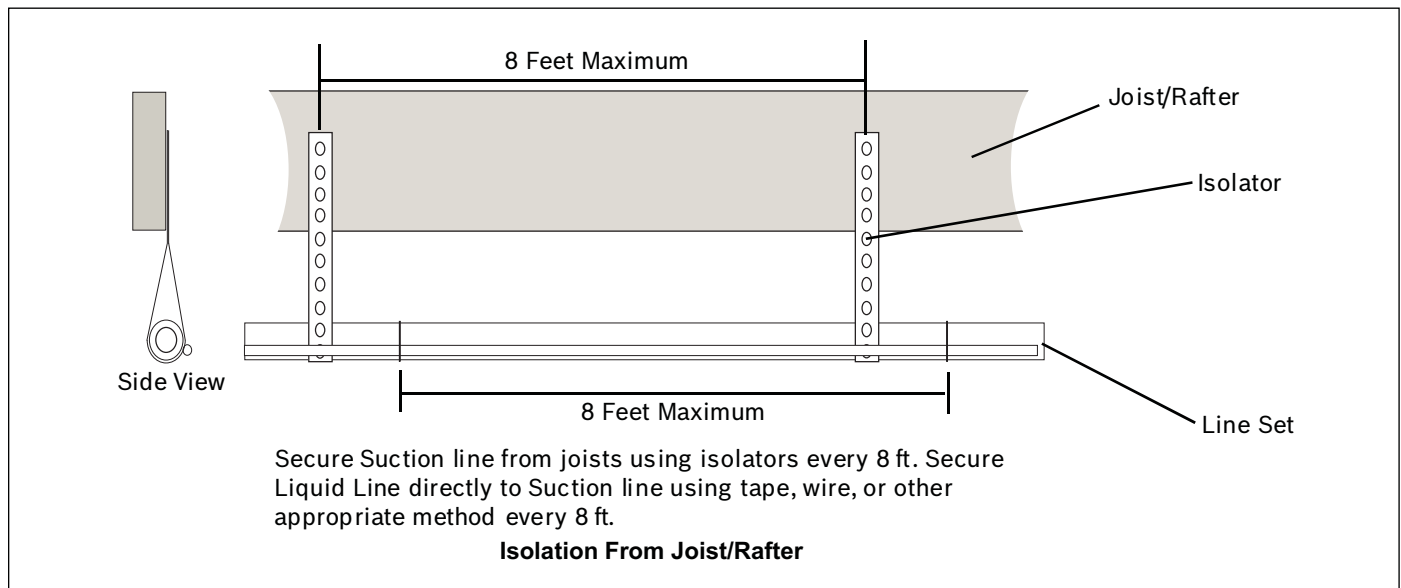

Figure 12

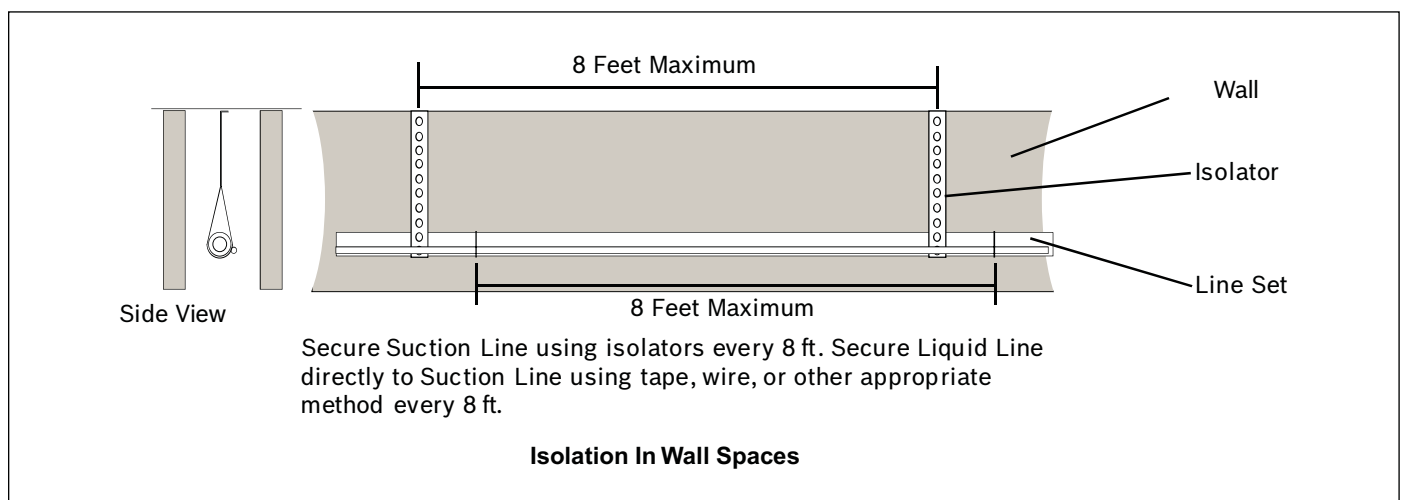

Figure 13

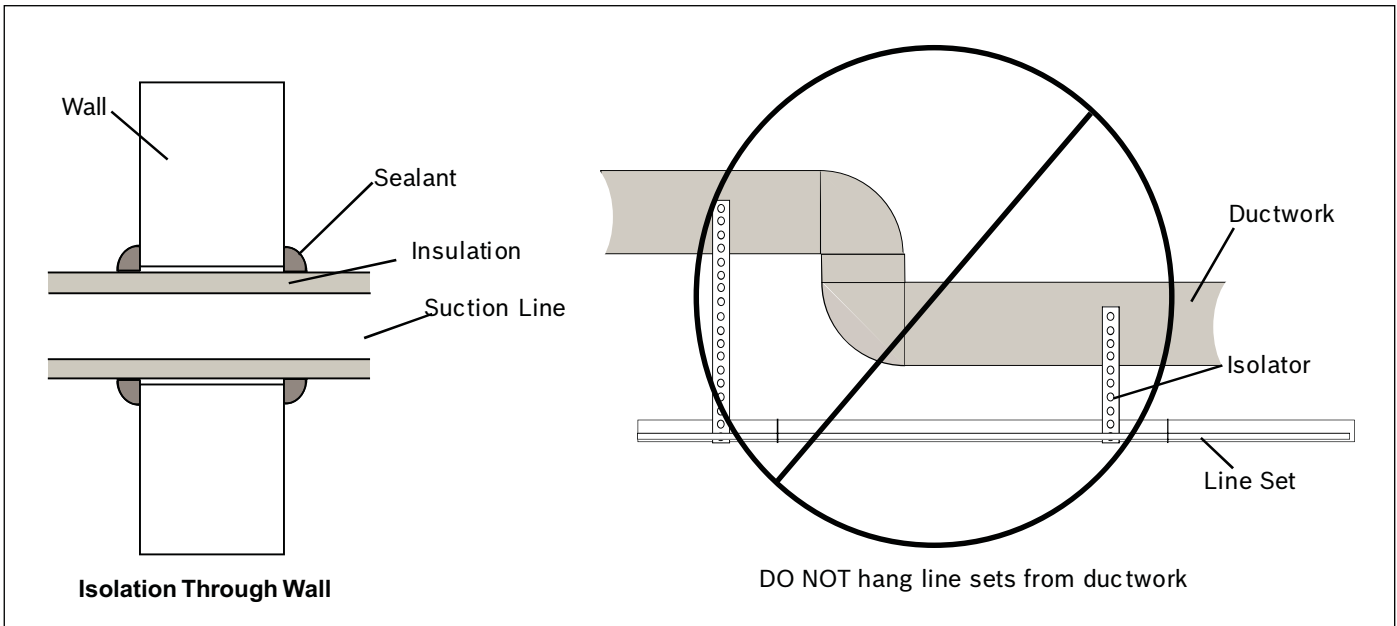

Figure 14

7 Refrigerant line brazing

7.1 Braze the refrigerant lines

1. Remove caps or plugs. Use a deburring tool to deburr the pipe ends. Clean both internal and external surfaces of the tubing using an emery cloth.

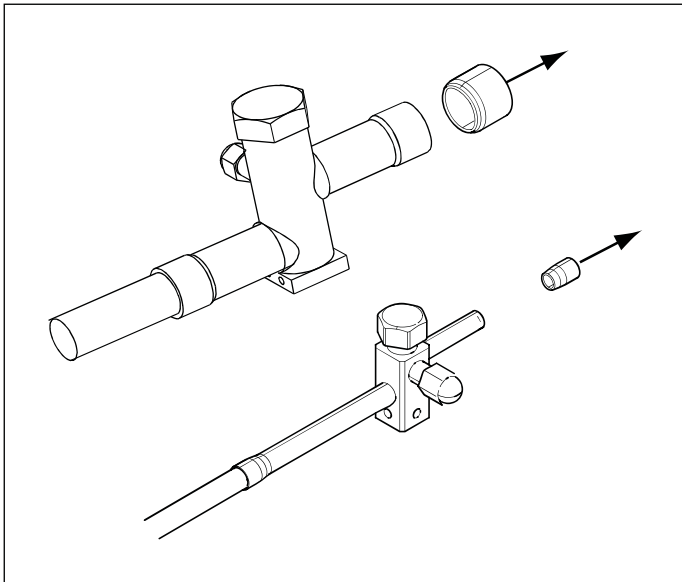

Figure 15

- Remove the pressure tap cap from both service valves.

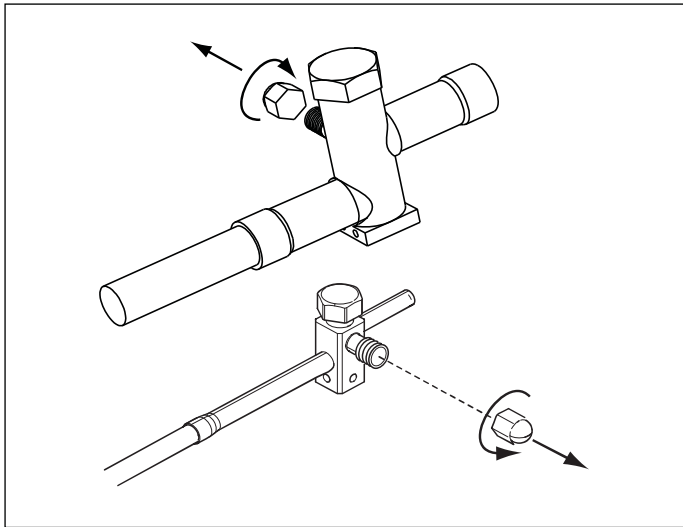

Figure 16

- Purge the refrigerant lines and indoor coil with dry nitrogen.

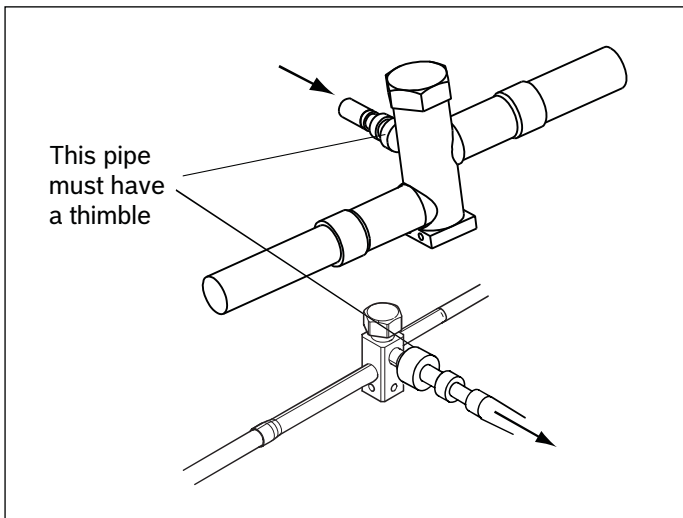

Figure 17

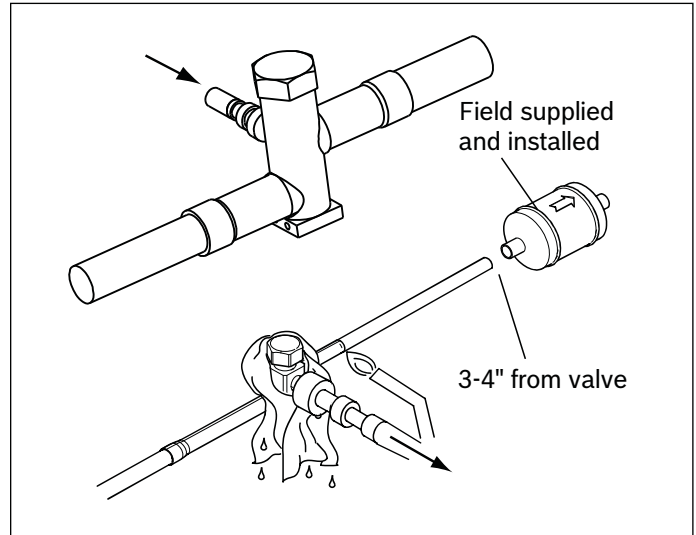

Figure 18

- Replace the pressure tap caps after the service valves have cooled.

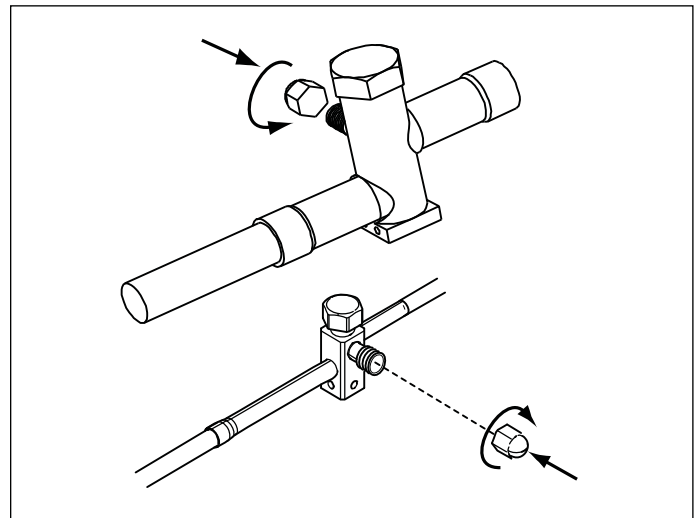

Figure 19

- Wrap a wet rag around the valve body to avoid heat damage and continue the dry nitrogen purge (Fig. 18).

Braze the refrigerant lines to the service valves.

Check liquid line filter drier's directional flow arrow to confirm correct direction of refrigeration flow (away from outdoor unit and toward evaporator coil) as illustrated. Braze the filter drier to the Liquid Line.

Continue the dry nitrogen purge. Do not remove the wet rag until all brazing is completed.



Remove the wet rag before stopping the dry nitrogen purge.

8 Refrigerant line leak check

8.1 Check for leaks

1. Pressurize the refrigerant lines and evaporator coil to 150 PSIG using dry nitrogen.

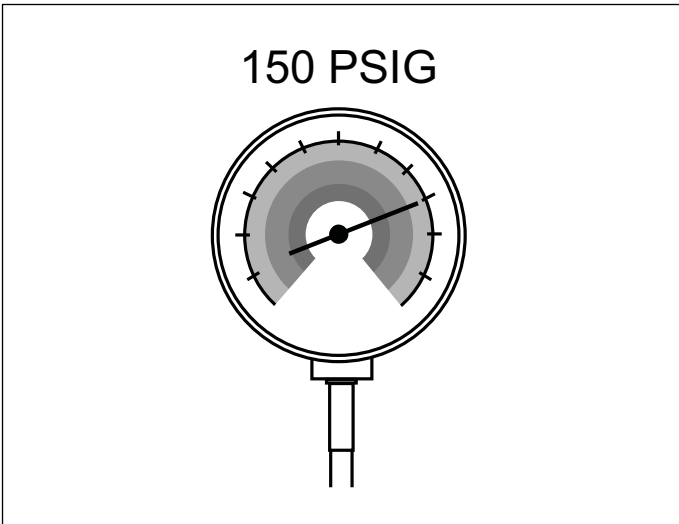

Figure 20

2. Check for leaks by using a soapy solution or bubbles at each brazed location.

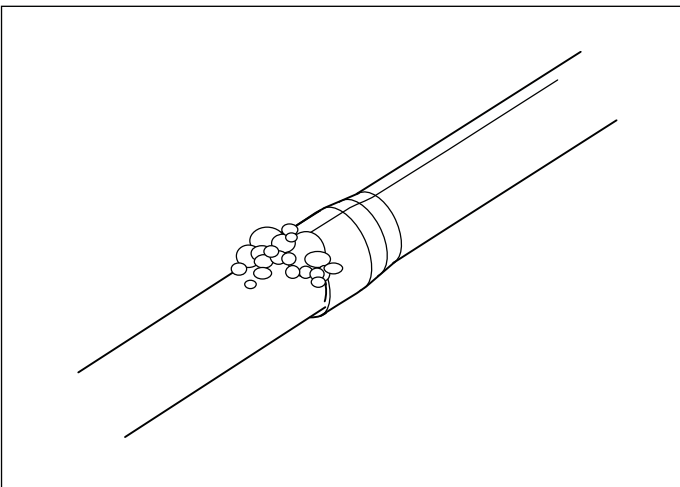

Figure 21

9 Evacuation

9.1 Evacuate the refrigerant lines and indoor coil



Do not open the service valves until the refrigerant lines and indoor coil leak check and evacuation are complete.

1. Evacuate until the micron gauge reads no higher than 350 microns, then close the valve to the vacuum pump.

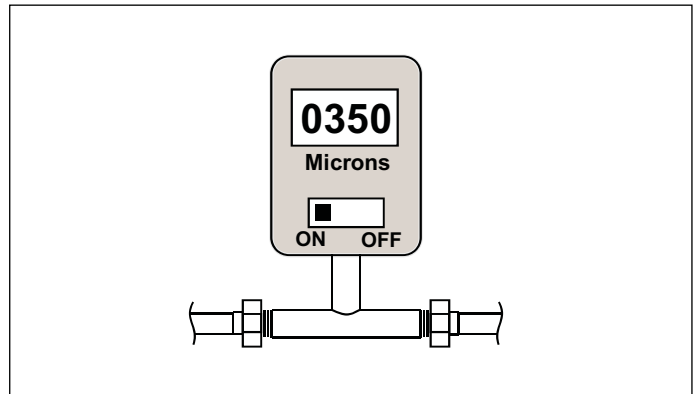

Figure 22

2. Observe the micron gauge. Evacuation is complete if the micron gauge does not rise above 500 microns in one (1) minute.

Once evacuation is complete blank off the vacuum pump and micron gauge, and close the valves on the manifold gauge set.



Figure 23

10 Service valves

10.1 Open the service valves



WARNING:

- ▶ Extreme caution should be exercised when opening the Liquid Line Service Valve. Turn counterclockwise until the valve stem just touches the rolled edge. No torque is required. Failure to follow this warning will result in abrupt release of system charge and may result in personal injury and /or property damage.



Leak check and evacuation must be completed before opening the service valves.



The Suction Service Valve must be opened first BEFORE opening the Liquid Service Valve!

1. Remove service valve cap (Fig 24).
2. Fully insert hex wrench into the stem and back out counterclockwise until valve stem just touches the rolled edge (approximately five (5) turns.)
3. Replace the valve stem cap to prevent leaks. Tighten finger tight plus an additional 1/6 turn.
4. Repeat STEPS 1 - 3 for Liquid Service Valve.

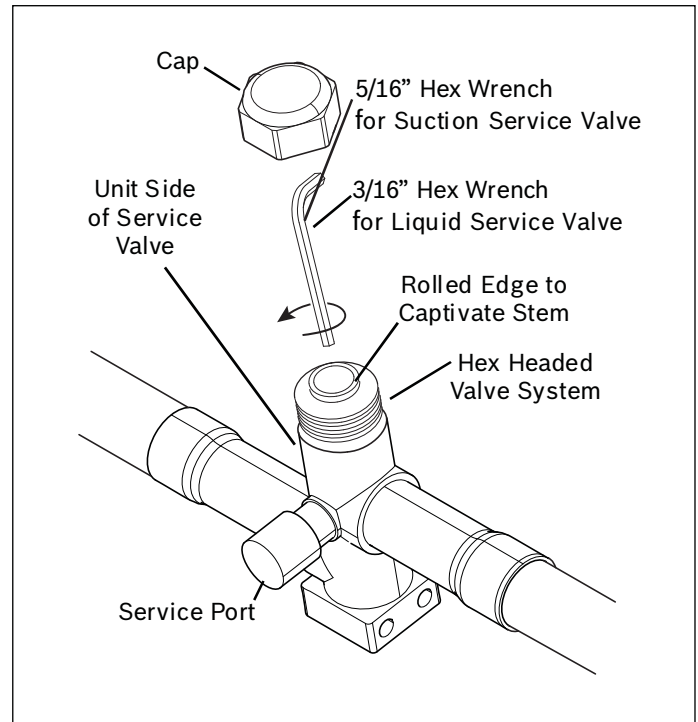

Figure 24

11 Electrical - low voltage

11.1 Low Voltage Maximum Wire Length

Table 3 defines the maximum total length of low voltage wiring from the outdoor unit, to the indoor unit, and to the thermostat.

24 Volts - Wire size	Max. wire length
18 AWG	150 Ft.
16 AWG	225 Ft.
14 AWG	300 Ft.

Table 3

11.2 Low voltage hook-up diagrams

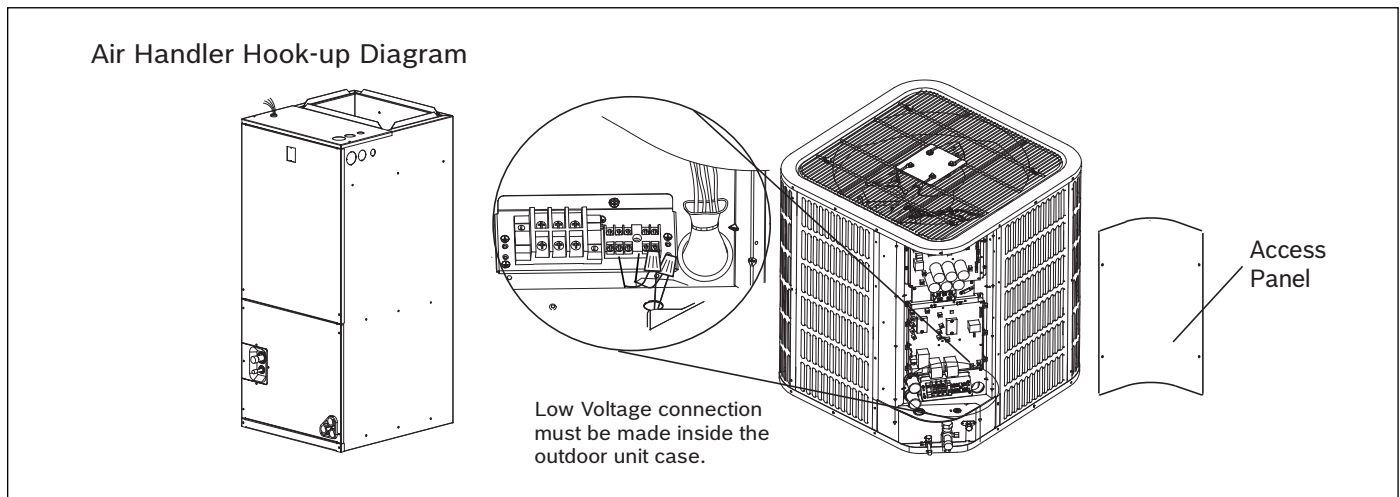

Figure 25

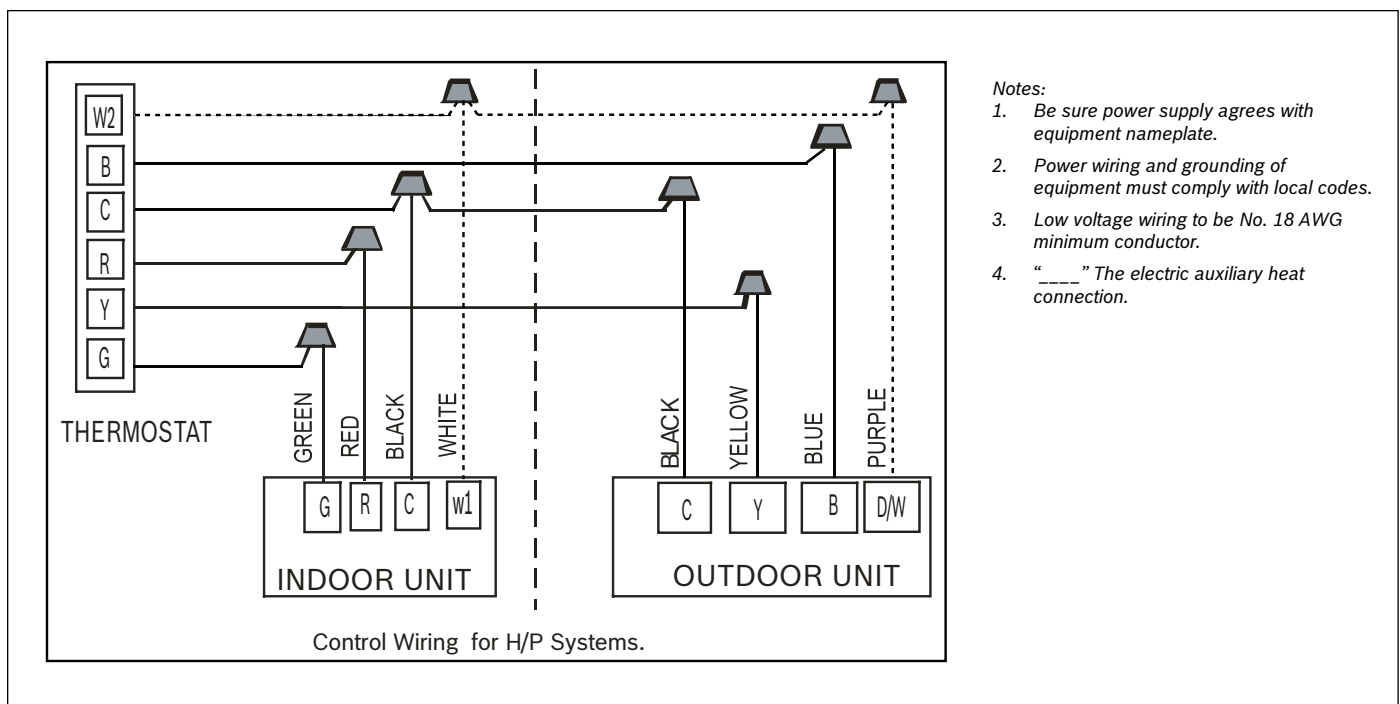

Figure 26

12 Electrical - high voltage

12.1 High voltage power supply



WARNING: LIVE ELECTRICAL COMPONENTS!

- ▶ During installation, testing, servicing, and trouble shooting of this product, it may be necessary to work with live electrical components. Failure to follow all electrical safety precautions when exposed to live electrical components could result in death or serious injury.

The high voltage power supply must agree with the equipment nameplate.

Power wiring must comply with national, state, and local codes.

Follow instructions on unit wiring diagram located on the inside of the control box cover and in the Service Facts document included with the unit.

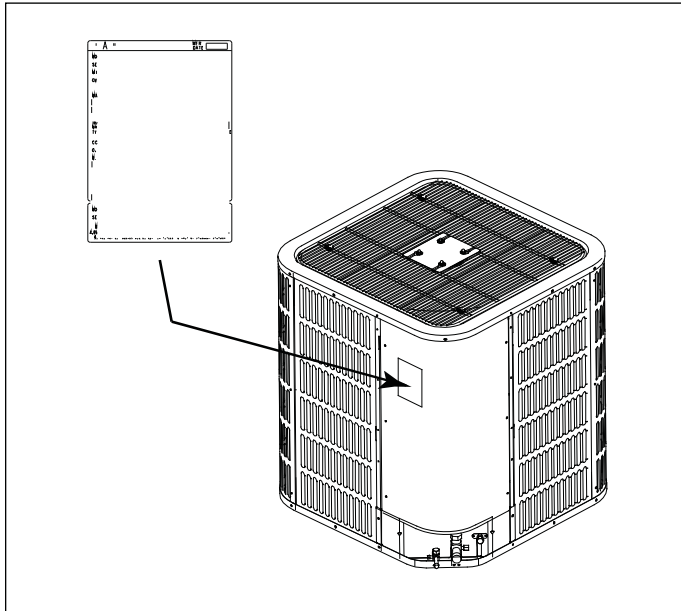

Figure 27

12.2 High voltage disconnect switch

Install a separate disconnect switch at the outdoor unit.

Field provided flexible electrical conduit must be used for high voltage wiring.

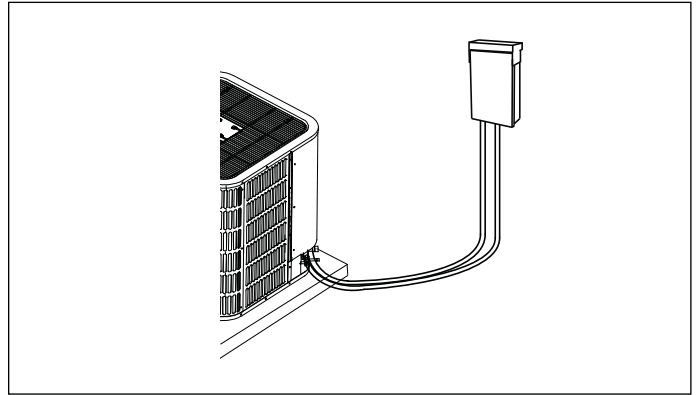

Figure 28

12.3 High voltage ground

Ground the outdoor unit per national, state, and local code requirements.

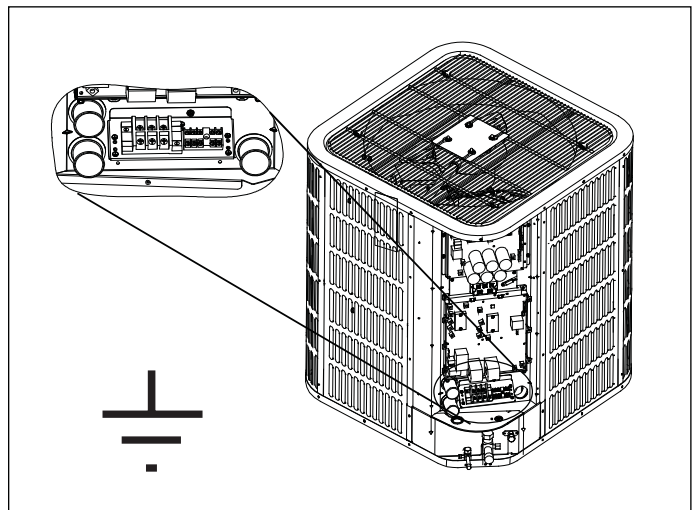

Figure 29

13 Start up

13.1 System start up

1. Ensure Sections 7, 8, 9, 10, 11, 12, and 13 have been completed.
2. Set System Thermostat to OFF.

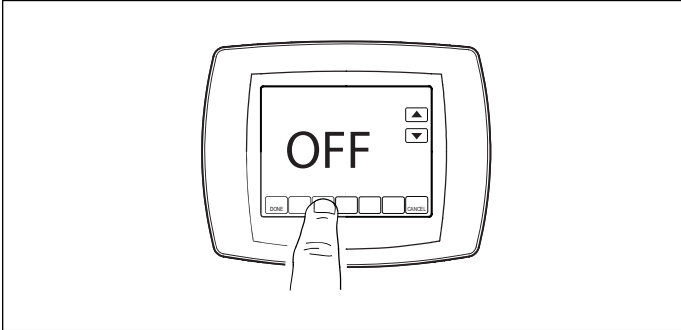

Figure 30

3. Turn on disconnect to apply power to the indoor and outdoor units.

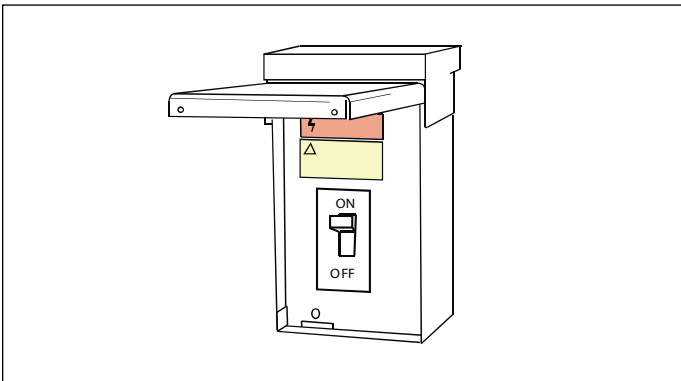

Figure 31

4. Wait one (1) hour before starting the unit if compressor crankcase heater is used and the outdoor ambient temperature is below 70 °F.



Figure 32

5. Set system thermostat to ON.

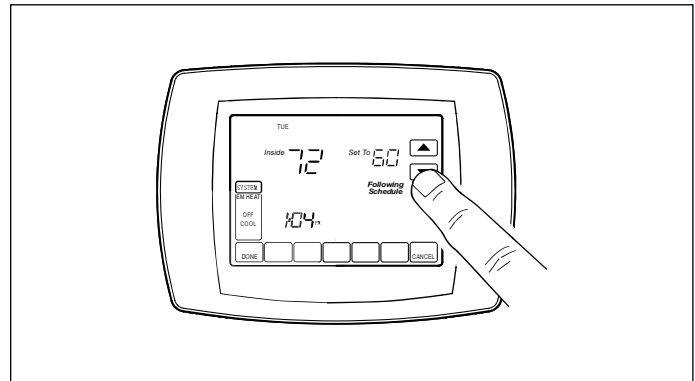

Figure 33

14 System charge adjustment

14.1 Charging: weigh-in method

Weigh-In method can be used for the Initial installation, or anytime a system charge is being replaced. weigh-In Method can also be used when power is not available to the equipment site or operating conditions (indoor/Outdoor temperatures) are not in range to verify with the subcooling charging method.

A	B	C
Model	Factory Charge	Charge multiplier for interconnecting refrigerant tube length
All models	The data on nameplate	0.6 oz/ft

Table 4

i The factory charge in the outdoor unit is sufficient for 15 feet of standard size interconnecting liquid line.

New Installations – Calculating additional charge for lineset greater than 15 ft.

- Total Line Length (ft) = _____(a)
- Standard Lineset (ft) = 15 (b)
- (a) minus (b) = _____(c)
- Refrigerant Multiplier = 0.6 oz/ft (d)
- Refrigerant Adder (c*d) = _____(e)*

*If lineset is less than 15 ft, (e) = 0

Sealed-System Repairs – Calculating total system charge.

- Total Line Length (ft) = _____(a)
- Standard Lineset (ft) = 15 (b)
- (a) minus (b) = _____(c)
- Refrigerant Multiplier = 0.6 oz/ft (d)
- Refrigerant Adder (c*d) = _____(e)*
- Factory Charge (nameplate) = _____(f)
- Total System Charge (e+f) = _____

*If lineset is less than 15 ft, (e) = 0

i The only mode approved for validating system charge is while in Cooling "Charge Mode". Outdoor Temperature must be between 55°F and 120°F with Indoor Temperature kept between 70°F and 80°F.

14.2 Subcooling charging and refrigerant adjustment in cooling (above 55°F outdoor temp.)

- Check the outdoor ambient temperatures.

Subcooling (in cooling mode) is the only recommended method of charging above 55°F outdoor ambient temperatures.

For outdoor ambient temperatures below 55°F, use weigh-in charge method. Note: It is important to return in the spring or summer to accurately charge the system in the cooling mode when outdoor ambient temperature is above 55°F.

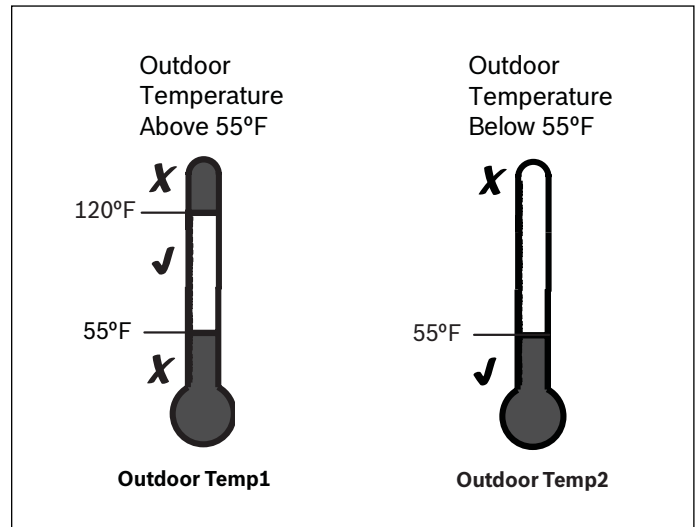

Figure 34

For best results the indoor temperature should be kept between 70°F to 80°F.

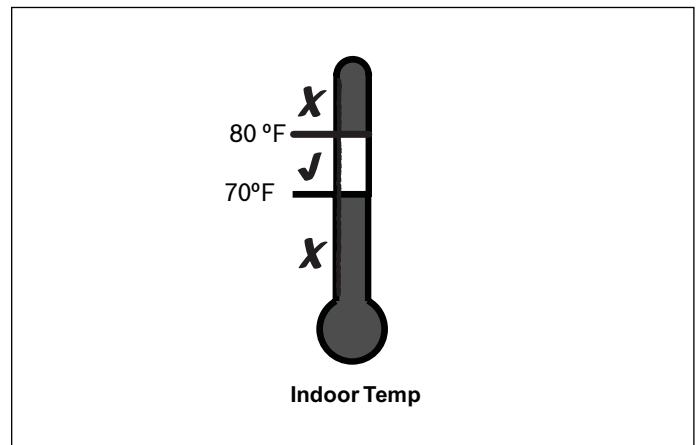

Figure 35

- Ensure Sections 7, 8, 9, 10, and 13 have been completed.
- Stabilize the system.

After starting the system in cooling mode, short press "FORCE" button, and "⊥" symbol appears in 10 minutes, operate the system for a minimum of twenty (20) minutes.

i After twenty (20) minutes stabilization period, maintain continuous operation while adjusting refrigerant charge or TXV, after which operate system for a minimum of five (5) minutes for system to stabilize, otherwise repeat step 3.

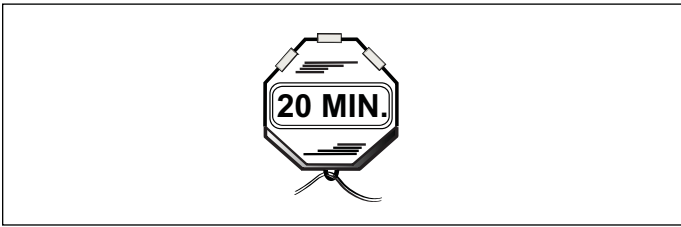

Figure 36

4. Calculate superheat value on suction valves (According to Table 4)

- ▶ Measured Suction Line Temp. = _____ °F
- ▶ Measured Suction Line Pressure = _____ PSIG
- ▶ Calculate superheat value = _____ °F

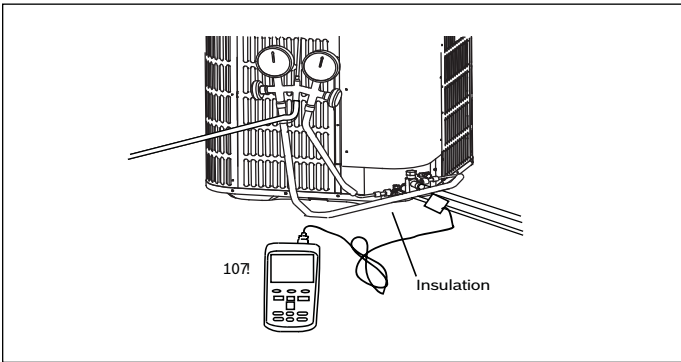

Figure 36

5. Calculate subcooling value on liquid valves (According to Table 5)

- ▶ Measured Suction Line Temp. = _____ °F
- ▶ Measured Suction Line Pressure = _____ PSIG
- ▶ Calculate superheat value = _____ °F

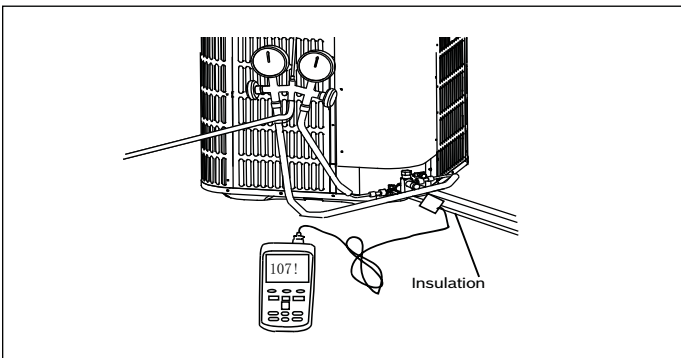

Figure 37

i If calculated subcooling value is lower than the design subcooling value (Table 6), please add refrigerant. Repeat the steps above.

Suction Temp (°F)	Final Superheat (°F)							
	8	10	12	14	16	18	20	22
	Suction Gage Pressure (PSI)							
40	101	97	93	89	86	82	78	75
42	105	101	97	93	89	86	82	78
44	110	105	101	97	93	89	86	82
46	114	110	105	101	97	93	89	86
48	118	114	110	105	101	97	93	89
50	123	118	114	110	105	101	97	93
52	128	123	118	114	110	105	101	97
54	133	128	123	118	114	110	105	101
56	138	133	128	123	118	114	110	105
58	143	138	133	128	123	118	114	110
60	148	143	138	133	128	123	118	114
62	153	148	143	138	133	128	123	118
64	159	153	148	143	138	133	128	123
66	164	159	153	148	143	138	133	128
68	170	164	159	153	148	143	138	133
70	176	170	164	159	153	148	143	138
72	182	176	170	164	159	153	148	143

Table 4 R-410A Refrigerant chart - Final Superheat

Suction Temp (°F)	Final Supercooling(°F)							
	6	7	8	9	10	11	12	13
	Liquid Gage Pressure (PSI)							
55	173	176	179	182	185	188	191	195
60	188	191	195	198	201	204	208	211
65	204	208	211	215	218	221	225	229
70	221	225	229	232	236	239	243	247
75	239	243	247	251	255	259	262	266
80	259	262	266	270	275	279	283	287
85	279	283	287	291	295	300	304	309
90	300	304	309	313	318	322	327	331
95	322	327	331	336	341	346	351	355
100	346	351	355	360	365	370	376	381
105	370	376	381	386	391	397	402	407
110	397	402	407	413	418	424	430	435
115	424	430	435	441	447	453	459	465
120	453	459	465	471	477	483	489	496
125	483	489	469	502	508	515	521	528

Table 5 R-410A Refrigerant chart- Final Subcooling

Model	24/36	48/60
Design subcooling	10°F ± 2°F	8°F ± 2°F

Table 6

6. Adjust refrigerant level to attain proper gage pressure.

i **Add refrigerant** if the design subcooling is lower than the chart value.

- ▶ Connect gages to refrigerant bottle and unit as illustrated (Fig 38).
- ▶ Purge all hoses.
- ▶ Open bottle.
- ▶ Stop adding refrigerant when subcooling matches the charging chart (Table 5) Final Subcooling value.

i **Recover refrigerant** if the design subcooling is lower than the chart value.

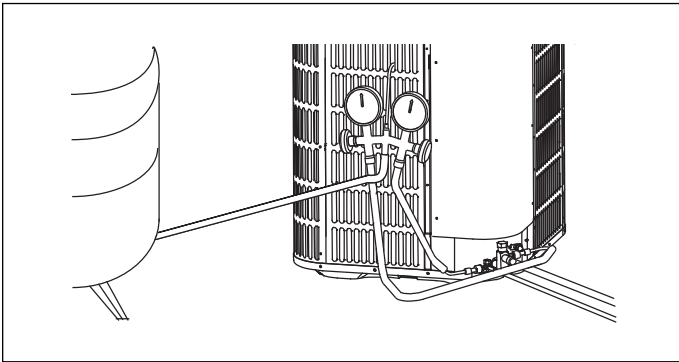

Figure 38

7. Stabilize the system.

- ▶ Wait 5 minutes for the system condition to stabilize between adjustments.

i When the subcooling matches the chart, the system is properly charged.

- ▶ Remove gages.
- ▶ Replace service port caps to prevent leaks. Tighten finger tight plus an additional 1/6 turn.



Figure 39

8. Record System Information for reference (Table 7).
Record system pressures and temperatures after charging is complete.

Description	Value
Outdoor model number	
Measured Outdoor Ambient	°F
Measured Indoor Ambient	°F
Measured Liquid Line Temp	°F
Measured Suction Line Temp	°F
Liquid Gage Pressure	PSIG
Suction Gage Pressure	PSIG

Table 7

15 System operation and troubleshooting

15.1 Control logic description

- ▶ The variable speed system adopts the same 24VAC control as any conventional Heat Pump.
- ▶ The compressor's speed is controlled based on coil pressures monitored by pressure transducer. To insure stable and adequate capacity, the compressor speed will modulate relative to evaporator pressure during cooling operation and relative to condensing pressure during heating operation. The target pressure can auto-matically adjust based on compressor operation so optimal capacity can be achieved. Target pressure can manually be adjusted (SW4) to achieve improved dehumidification and capacity demands.

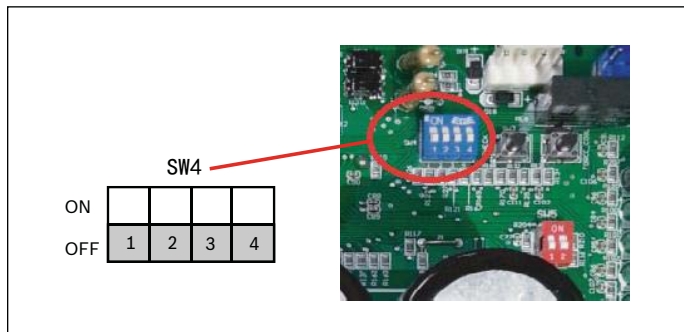

Figure 40

Switch	Description	
SW4-1	Not used	
SW4-2	Not used	
SW4-3	ON	Adaptive capacity output disable
	OFF	Adaptive capacity output enable
SW4-4	ON	Accelerated cooling/heating
	OFF	Normally cooling/heating

Table 8

15.2 Sensors (thermistors/pressure transducer)

- ▶ t3 = Outdoor Coil Temperature (Table 1)
 - High/Low temperature protection
 - Outdoor fan control (cooling mode)
 - Defrost control (heating mode)
 - Ambient Temperature forecast
- ▶ T4 = Ambient Temperature (Table 1)
 - Operating condition permission
 - Defrosting condition permission
 - Outdoor fan control (heating mode)
- ▶ T5 = Compressor Discharge Temperature (Table 2)
 - High/Low temperature protection
 - Electronic Expansion Valve (EEV) control (ODU)

- ▶ TF = IPM Radiator Temperature) (Table 2)
 - Inverter High Temperature Protection
- ▶ Pressure transducer (Table 3)
 - Operating speed control
 - Electronic Expansion Valve (EEV) control (ODU)
 - High pressure protection (heating mode)
 - Low pressure protection (cooling mode)

15.3 Defrost description

- ▶ The Demand Defrost Control (DDC) monitors the ODU coil temperature using thermistor (T3). A second thermistor (T4) monitors outdoor ambient temperature. Based on these parameters, as well as accumulative run time and high pressure, the DDC calculates proper initiation of defrost.
- ▶ The following three conditions are required to enter defrost:
 1. Outdoor coil temperature T3 < 34°F and a corresponding minimum outdoor ambient temperature is met.
 2. After "Minimum Run Time" (MRT) is achieved. MRT is based on outdoor ambient temperature (T4), for example:
 - MRT is 4 hours when: T4 < 23°F
 - MRT is 2 hours when: 23°F ≤ T4 < 42°F
 3. After the high pressure saturation temperature drops below 82°F for 20 minutes.
- ▶ Defrost will terminate once outdoor coil temperature (T3) reaches 64°F for a period of 1 minute or defrost time has exceeded 8 minutes.
- ▶ Defrost Termination Settings (SW5) offers different defrost termination options for enhanced defrost for different geographical &/or outdoor conditions.

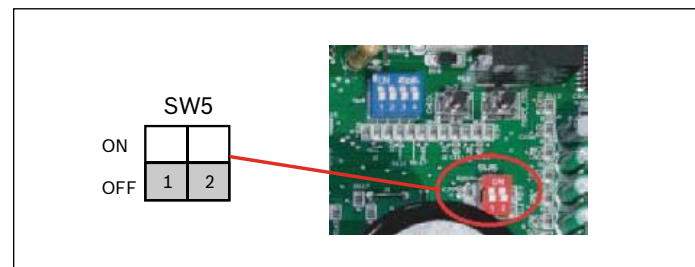

Figure 41

Defrosting choice	SW5-1	SW5-2	Remarks
ON	Operating time is reduced by 10%	Defrosting extended for 60 seconds	
OFF	Normal	Normal	Default
Remarks	Enter defrost	Quit defrost	

Table 8

- ▶ Manual Defrost:
 1. System must have a call for heat and have been operating for a minimum of 8 minutes.
 2. Press "Force" button on inverter board for 6 seconds to begin forced defrost.
 3. Wait approximately 40 seconds for defrost to initiate.
 4. Once defrost initiates, the display will indicate "dF".
 5. Defrost test will terminate automatically, after which the display will indicate running speed.
 6. If a second defrost test is required, repeat step 3 after 5 minutes.

15.4 Compressor crankcase heater description

Refrigerant migration during the OFF cycle can result in noisy start-ups, therefore a crankcase heater (CCH) is used to minimize refrigerant migration thereby minimizing start-up noise and/or bearing "wash out". All CCHs must be installed on the lower half of the compressor shell. Its purpose is to warm the compressor on the OFF cycle, driving refrigerant from compressor. At initial start-up or after extended shutdown periods, allow CCH to be energized for at least 12 hours prior to compressor operation by applying line voltage to heat pump with thermostat OFF.

- ▶ CCH operation energizes:
 1. First time line voltage is applied and compressor discharge temperature $T5 < 104^{\circ}\text{F}$.
 2. In process of defrosting.
 3. Compressor stops running for 4 hours and outdoor ambient temperature $T4 < 50^{\circ}\text{F}$ or $T5 < 104^{\circ}\text{F}$.
- ▶ CCH operation de-energizes:
 1. Compressor discharge temperature $T5 \geq 113^{\circ}\text{F}$.

15.5 Reversing valve operation

- ▶ Reversing valve energizes during heat mode and de-energizes in cool mode.

15.6 Protection functions

- ▶ Outdoor coil temperature protection (T3)
 - i. If $T3 > 143.6^{\circ}\text{F}$, compressor is de-energized
 - ii. If $T3 < 129.2^{\circ}\text{F}$, compressor is energized
- ▶ Ambient temperature protection (T4)
 - i. If $50^{\circ}\text{F} \leq T4 < 140^{\circ}\text{F}$, unit can operate in cooling
 - ii. If $-4^{\circ}\text{F} \leq T4 < 86^{\circ}\text{F}$, unit can operate in heating
 - iii. If $T4 < 6.8^{\circ}\text{F}$, heat pump will provide 24V control to indoor unit energizing electric heat (if installed).
- ▶ Discharge Temperature (DT) protection (T5)
 - i. If $DT > 239^{\circ}\text{F}$ during cooling mode, the compressor will stop.
 - ii. If $DT < 194^{\circ}\text{F}$ during cooling mode, the compressor will restart.
 - iii. If $DT > 221^{\circ}\text{F}$ during heating mode, the compressor will stop.
 - iv. If $DT < 167^{\circ}\text{F}$ during heating mode, the compressor will restart.
- ▶ High pressure protection (HPS) (mechanical open/close pressure switch)
 - i. HPS opens at $P > 580$ PSIG, the compressor and outdoor fan stop.
 - ii. HPS closes at $P < 435$ PSIG, the compressor and outdoor fan restart.
- ▶ Low pressure protection (LP)
 - i. If Low Pressure < 43.5 PSI for 5 minutes during cooling mode, the compressor and outdoor fan will stop. System will attempt to run again after 6 minutes.
- ▶ Module (inverter) protection (TF)
 - i. If $TF > 176^{\circ}\text{F}$, the compressor and outdoor fan will stop.
 - ii. If $TF < 145^{\circ}\text{F}$, the compressor and outdoor fan will restart.

15.7 Fault code table

Code	Fault Description
E4	Temperature sensor fault(T3, T4, T5, TF)
E5	High/low voltage protection
E6	DC fan motor fault
E7	Compressor discharge sensor(T5) is seated fault
E9	EEPROM fault
Eb	System lockup, 2 times (E6) protection in 10 minutes
H0	Communication fault in main control chip
H4	System lockup, 3 times (P6) protection in 60 minutes
H5	System lockup, 5 times (P2) protection in 100 minutes
H8	Pressure transducer(PT) fault
Hb	High pressure(PT) protection in Heating
P0	High module radiator temperature (TF)protection
P1	High pressure switch(HPS)protection
P2	Low pressure(PT) Protection in cooling
P3	Compressor over current protection
P4	High compressor discharge temperature(T5) protection
P5	condensor coil temperature(T3) protection in cooling
P6	The IPM module protection
PH	Low discharge superheat protection
F1	High pressure switch(HPS) fault
C3	The condensor coil sensor(T3) is seated fault in cooling
L0-L9	The IPM module protection (the same as P6,only for analysis)
AtL	Ambient Temperature Limited
System Protection Status Codes	
┆	Indication under charge model
L	Running indication under T3 limited condition
D	Running indication under T5 limited condition
P	Running indication under compressor ratio limited condition
F	Running indication under Tf limited condition
C	Running indication under current limited condition
U	Running indication under low voltage limited condition
H	Running indication under high pressure(PT) limited condition in heating
A	Running indication under return oil model
dF	Running indication under defrost model

Table 9

15.8 Parameter point check table

- ▶ To display system parameters, press the “Check” button to index through the series of parameters available. The first time you press on the “Check” button, it will display the sequence, and after 1 second it will display the value of the parameter. If you press the “Check” button again, it will display the next sequence.
- ▶ Normal Status, last two digits will display under following conditions
 - i. Unit not operating(Standby Mode); “outdoor ambient temperature”.
 - ii. Unit operating; displays “compressor operating frequency”.
- ▶ After 20 seconds on same parameter, display will revert back to normal status.
- ▶ If a system protection is active, first digit will display “status code”.

No.	Point check content	Example	Remark
0	Outdoor unit capacity	H3	H3=Heat Pump 3 ton
1	Outdoor unit mode	2	0 standby, 2 cooling, 3 heating
2	Outdoor unit set compressor speed		
3	Opening of EEV		Actual value
4	T3(outdoor coil temp.) (°F)		
5	T4 (outdoor ambient temp.) (°F)		
6	T5(compressor discharge temp.) (°F)		
7	Reserved		
8	Te (evaporating temp.) (°F)		
9	Tc (condensing temp.) (°F)		
10	Tf (module temp.) (°F)		
11	Pe (evaporating pressure) (PSI)		
12	Pc (evaporating pressure) (PSI)		
13	Compressor discharge superheat (°F)		Actual value
14	Reserved		
15	Reserved		
16	Compressor current (A)		
17	Reserved		
18	Fan speed		
19	Reserved		
20	Reserved		
21	Compressor discharge superheat (only useful for heating mode) (°F)		Target Value
22	Reserved		
23	Last Fault Code		
24	Software version		
25	Remark“--”		

Table 10

15.9 Control board overviews

For 2436 model

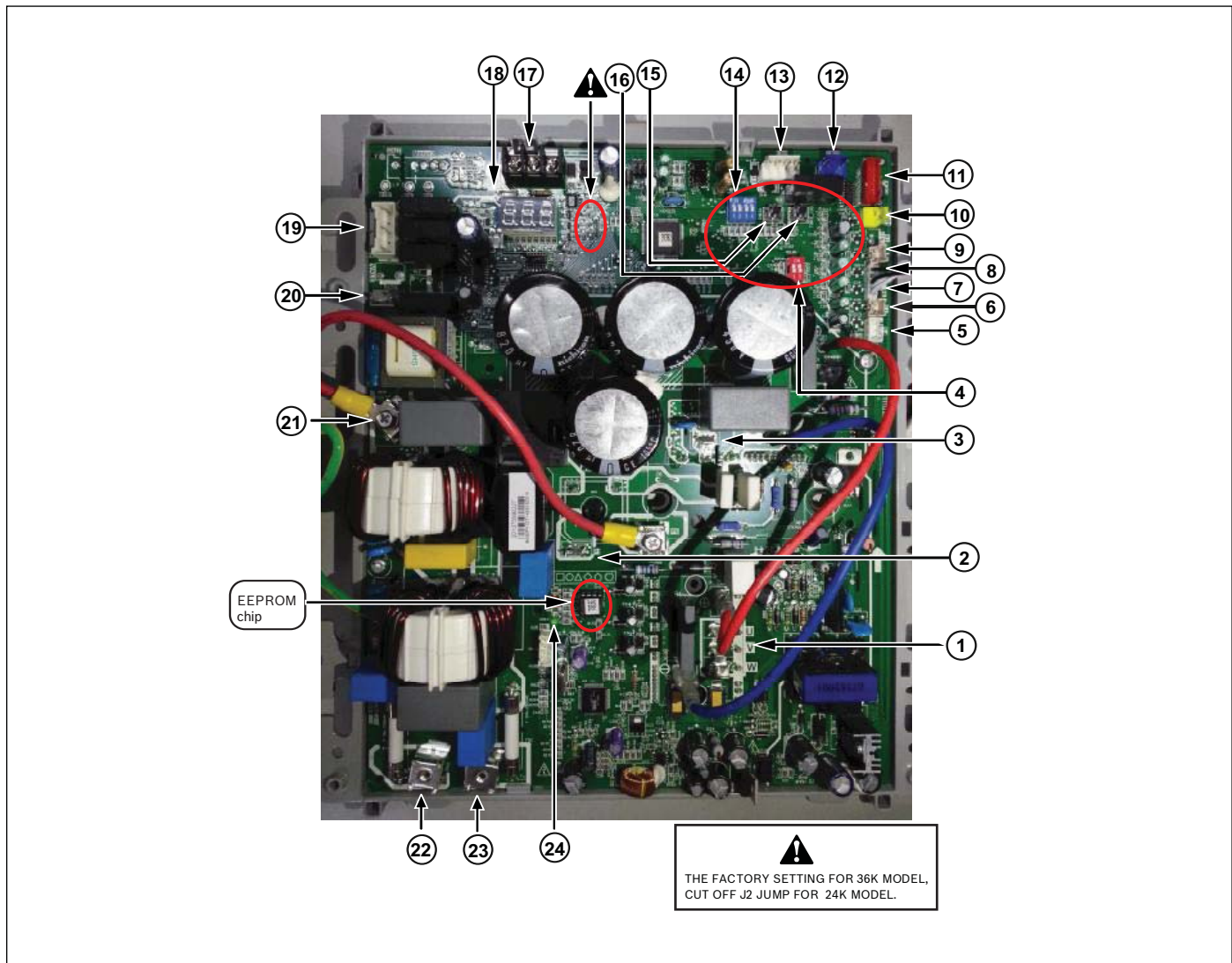

Figure 42

* The photo is just for reference, actual unit will verify.

No.	Function description	No.	Function description
1	Compressor wiring terminal	13	Temp. controller connecting port
2	Reactor wiring terminal(connect a reactor between 2 and 3)	14	Function dial code SW4
3	Reactor wiring terminal(connect a reactor between 2 and 3)	15	Spot check button
4	Defrosting function dial code SW5	16	Forced operation button
5	Pressure transducer port	17	Reserved
6	Air discharge temp.sensor port	18	Digital tube display
7	Outdoor temp.sensor port(HP only)	19	Fan control port
8	Condenser temp.sensor port	20	Crankcase heating zone control terminal
9	Radiator temp.sensor port	21	Short wire
10	High pressure switch port	22	Power supply connecting terminal
11	EEV drive port(HP only)	23	Power supply connecting terminal
12	Reversing valve port	24	Indicator lamp

Table 11

For 4860 model

Main control board

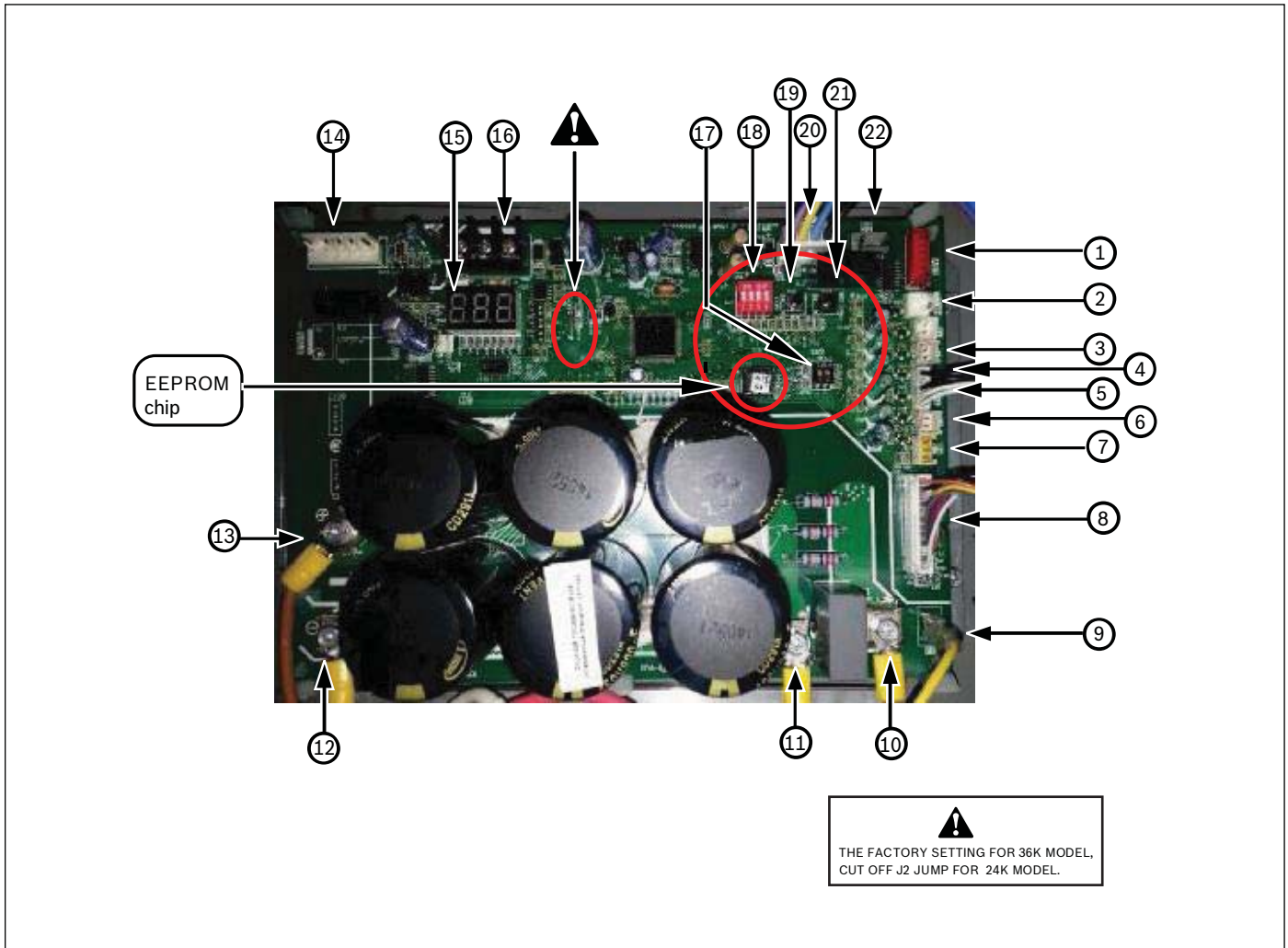

Figure 43

* The photo is just for reference, actual unit will verify.

No.	Function description	No.	Function description
1	EEV driving port (HP only)	12	The voltage between 12 and 13 is 380Vdc (Compressor is running)
2	High pressure switch port	13	The voltage between 12 and 13 is 380Vdc (Compressor is running)
3	Radiator temp. sensor port	14	DC motor control port
4	Condenser temp. sensor port	15	Nixie tube display
5	Outdoor temp. sensor port (HP only)	16	Reserved
6	Air discharge temp. sensor port	17	Defrosting function dial code SW5
7	Pressure transducer	18	Function dial code SW4
8	Connection wire port between main boards	19	Point check button
9	DC motor driving source (15V-P2)	20	Temp. controller connection port
10	The voltage between 10 and 11 is 380Vdc (Compressor is running)	21	Forced operation button
11	The voltage between 10 and 11 is 380Vdc (Compressor is running)	22	4-way valve port (HP only)

Table 12

For 4860 model

Drive board

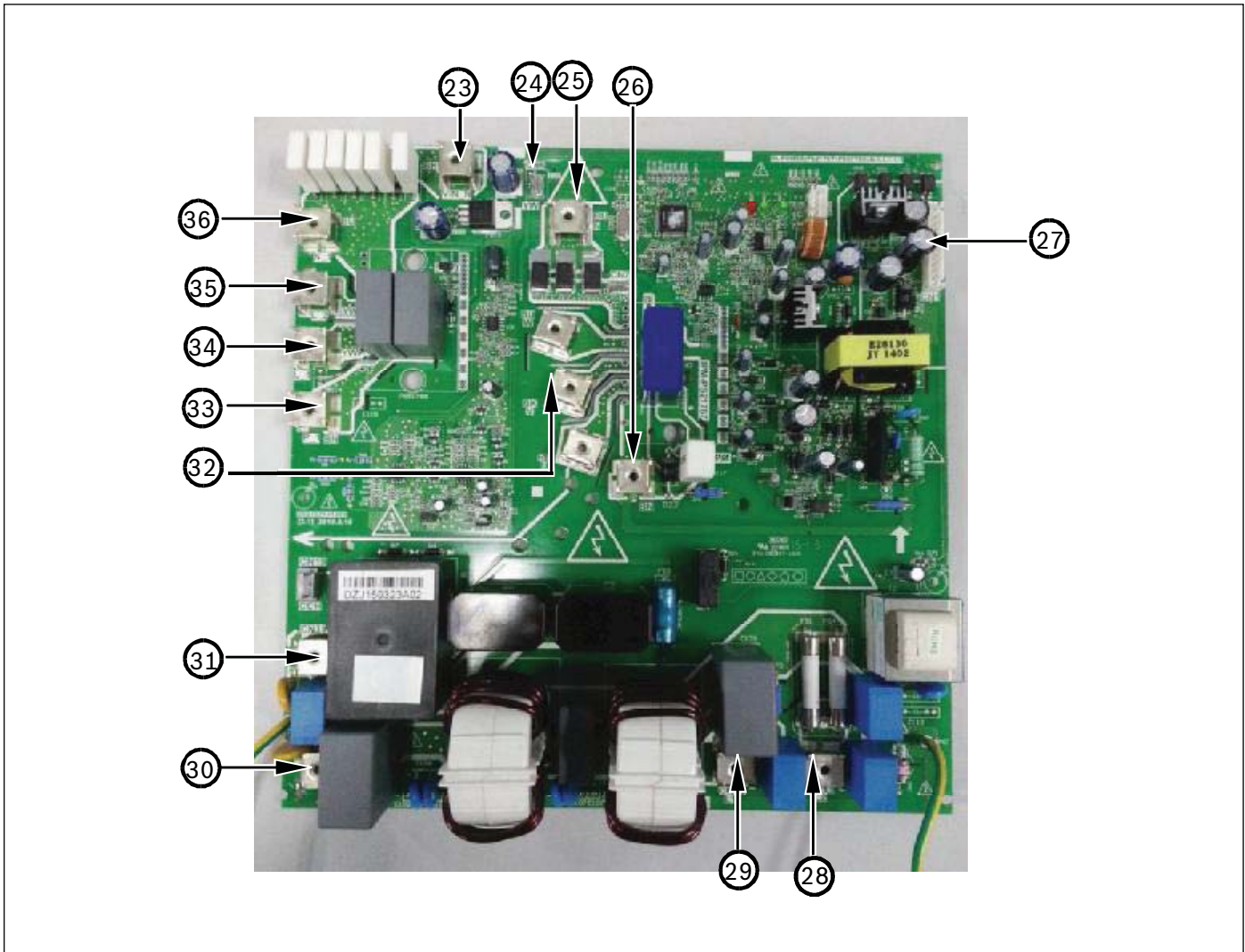

Figure 44

* The photo is just for reference, actual unit will verify.

No.	Function description	No.	Function description
23	Connect the cathode of the rectifier bridge	30	AC power supply output port
24	DC motor driving source(15V-P2)	31	AC power supply output port
25	The voltage between 25 and 26 is 380Vdc (Compressor is running)	32	Compressor connection terminal
26	The voltage between 25 and 26 is 380Vdc (Compressor is running)	33	The voltage between 33 and 36 is 380Vdc (Compressor is running)
27	Connection wire port between main boards	34	Reactor L1 wiring terminal
28	AC power supply input port	35	Reactor L2 wiring terminal
29	AC power supply input port	36	The voltage between 33 and 36 is 380Vdc (Compressor is running)

Table 13

15.10 Error code troubleshooting

Error Code	Description
P1	High pressure switch(HPS)protection
P5	Condenser coil temperature(T3) protection in cooling
Hb	High pressure(PT) protection in Heating
P3	Compressor over current protection

Table 14

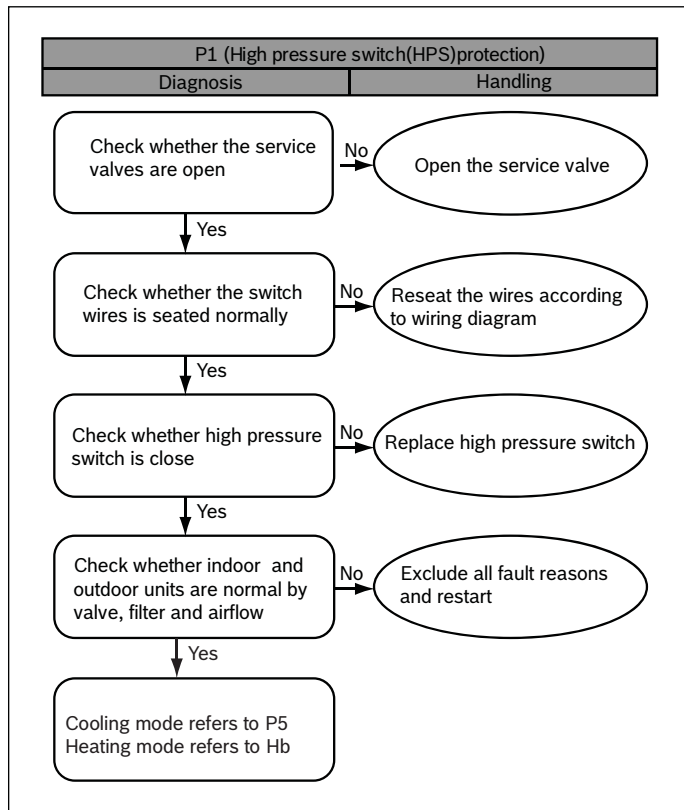

Figure 45

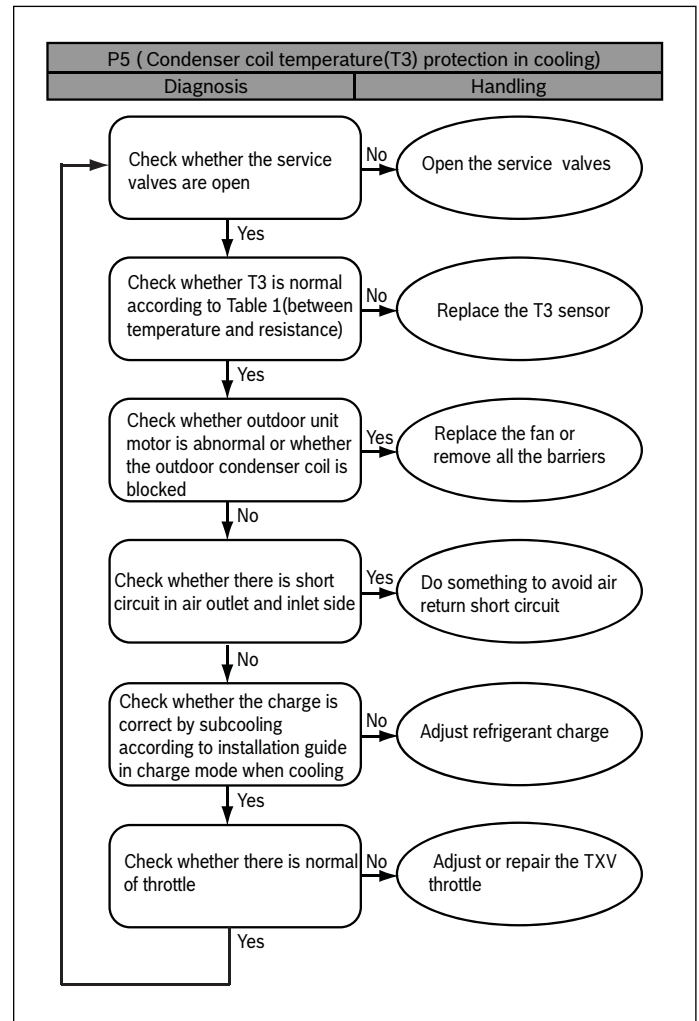

Figure 46

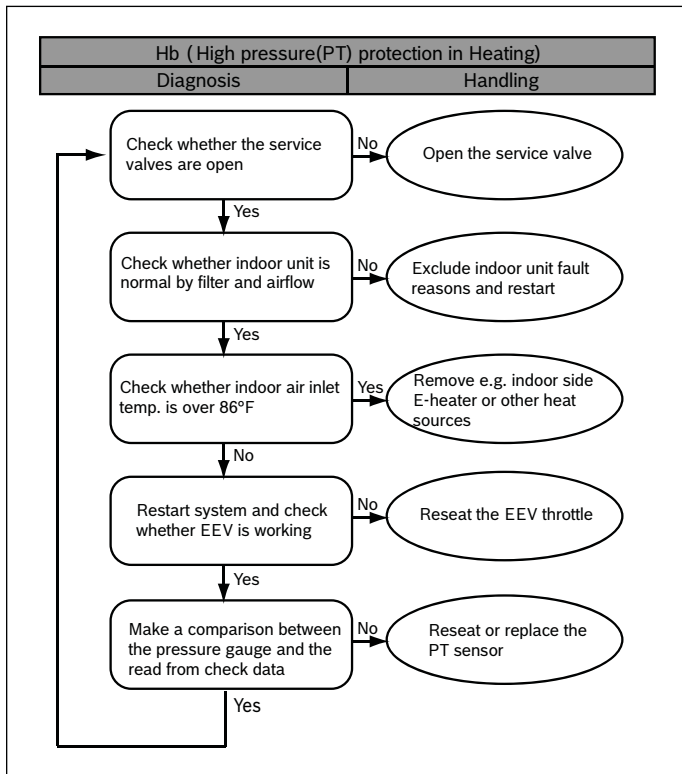

Figure 47

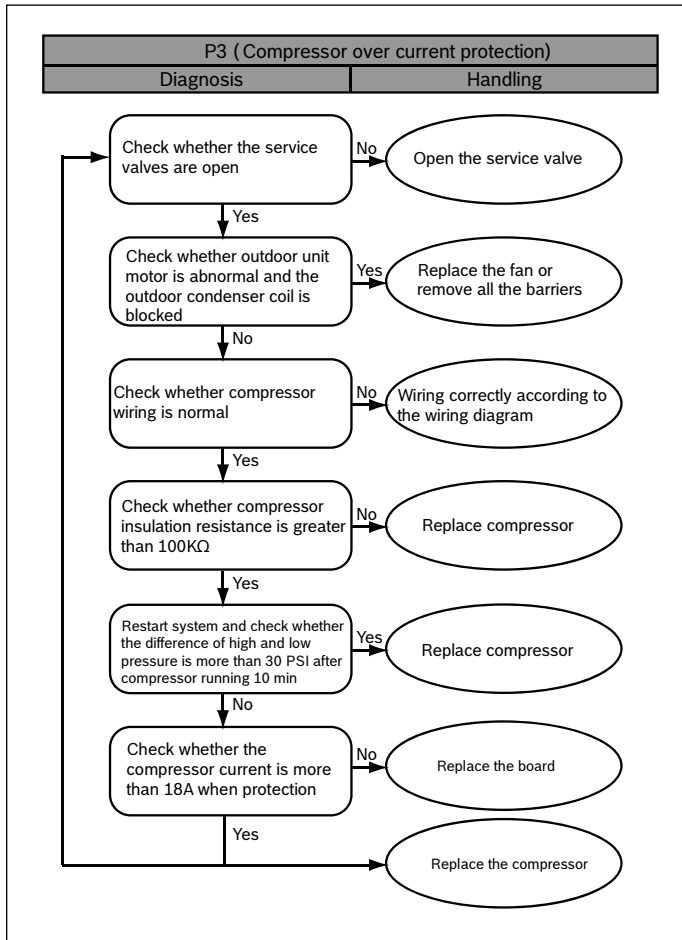

Figure 48

Error Code	Description
P0	High module radiator temperature (TF) protection

Table 15

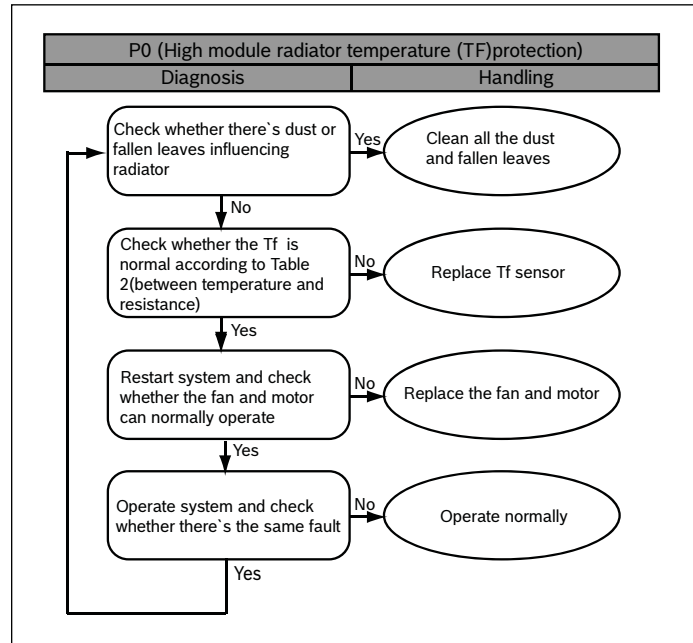

Figure 49

Error Code	Description
P2	Low pressure(PT) Protection in cooling
H5	System lockup, 5 times (P2) protection in 100 minutes
P4	High compressor discharge temperature(T5) protection

Table 16

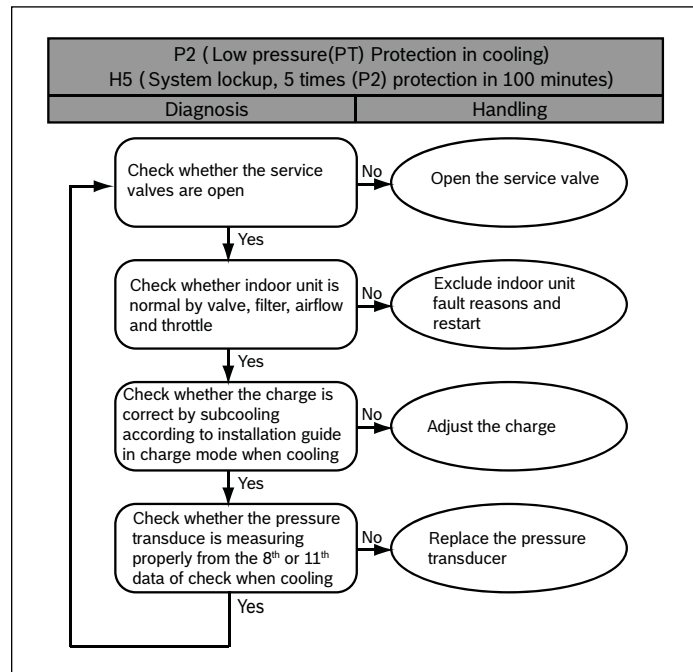

Figure 50

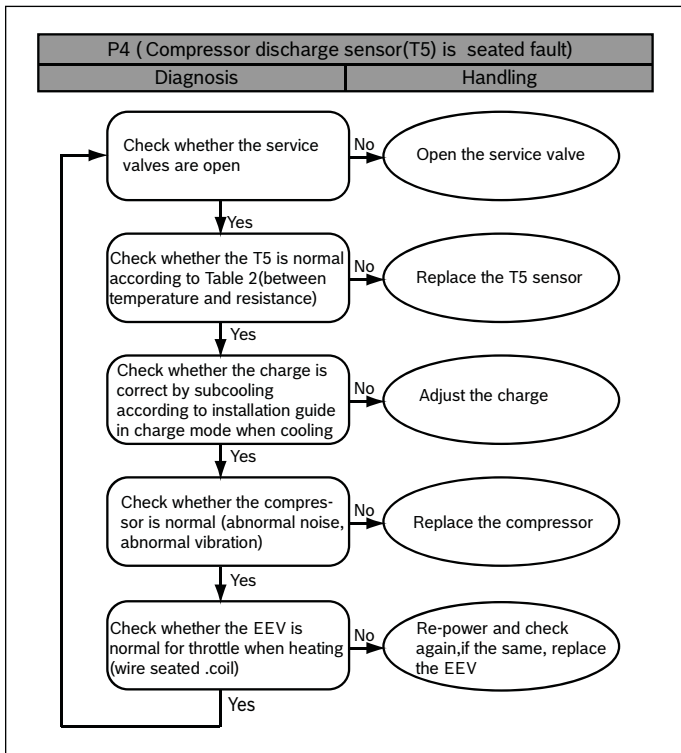

Figure 51

Error Code	Description
PH	Low discharge superheat protection

Table 17

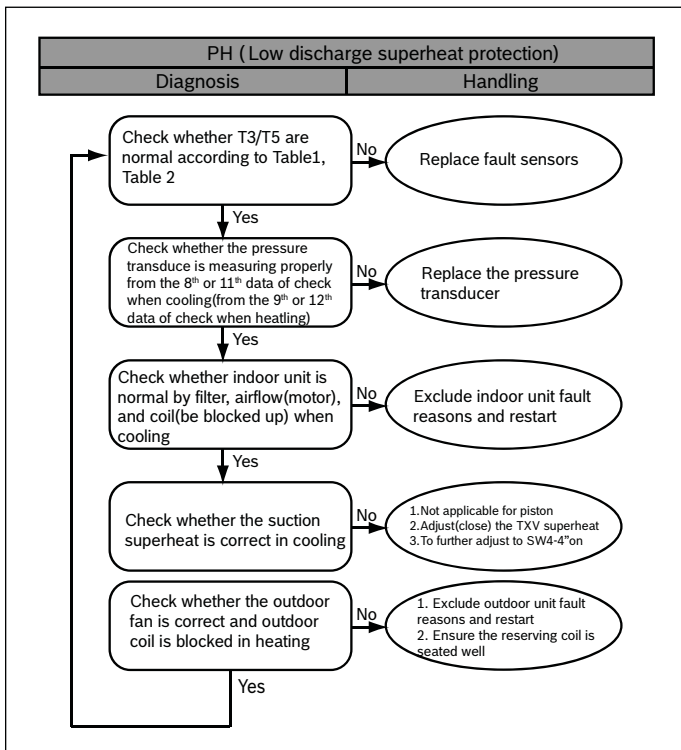

Figure 52

Error Code	Description
E4	Temperature sensor fault(T3, T4, T5, TF)
H8	Pressure transducer(PT) fault
F1	High pressure switch(HPS) fault

Table 18

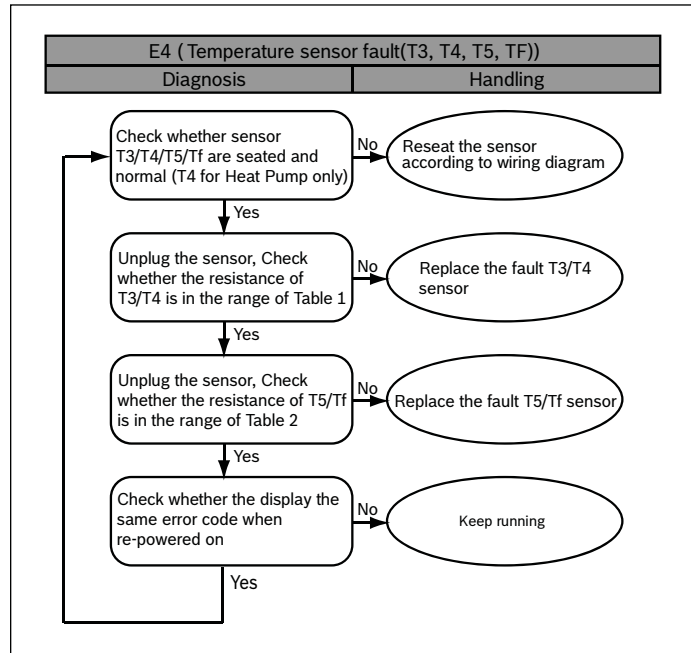

Figure 53

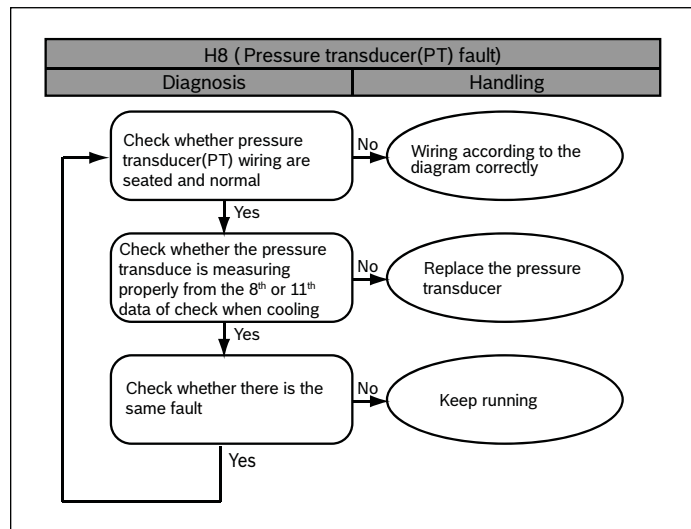

Figure 54

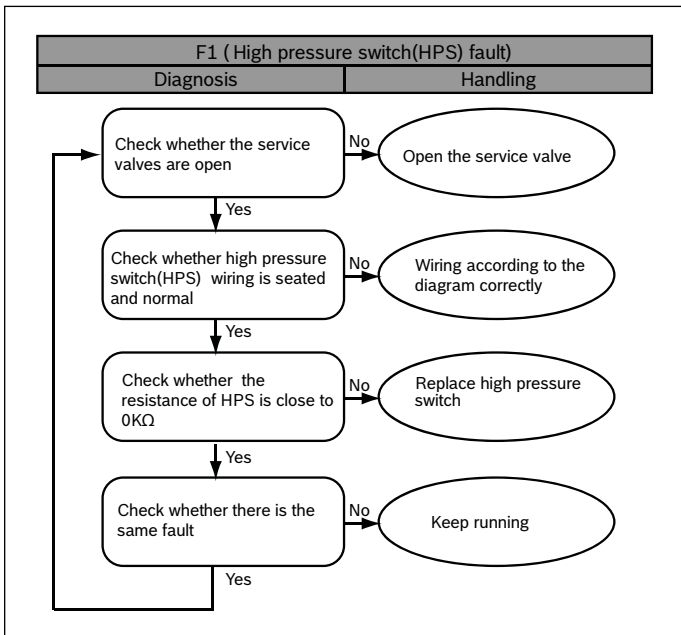

Figure 55

Error Code	Description
C3	Condenser coil sensor(T3) is seated fault in cooling
E7	Compressor discharge sensor(T5) is seated fault

Table 19

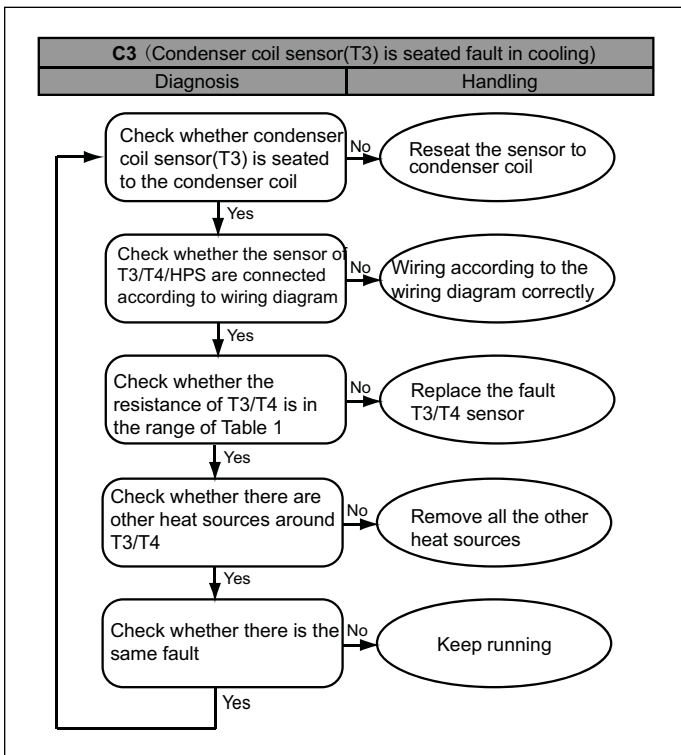

Figure 56

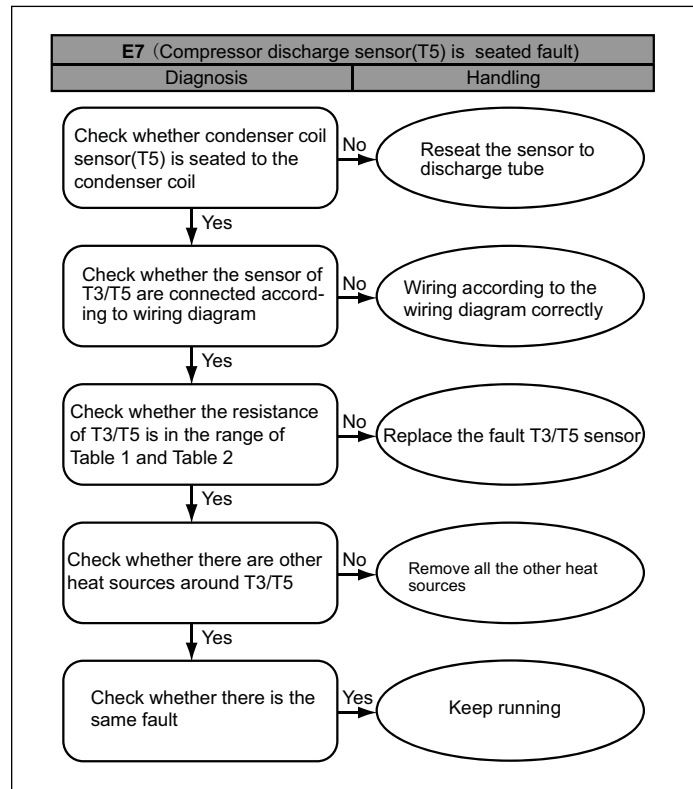

Figure 57

Error Code	Description
E6	DC fan motor fault
Eb	System lockup, 2 times (E6) protection in 10 minutes

Table 20

When E6 appears occasionally, you don't need to do anything, the system will restart automatically after 6 minutes, of course, if you check the system of running, it will be better. When Eb appears, you need to check the motor.

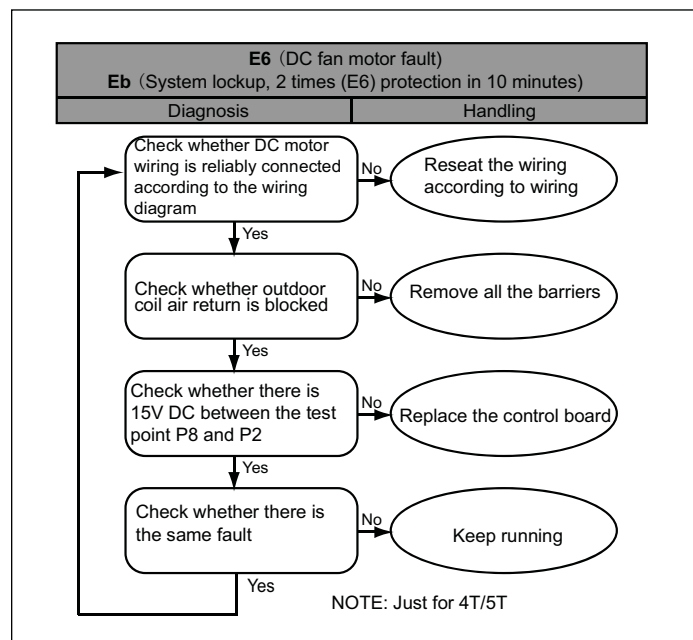

Figure 58

Error Code	Description
E9	EEPROM fault
H0	Communication fault in main control chip
E5	High/low voltage protection

Table 21

When E9/H0/E5 appears occasionally, and the system restart to run normally after power supply again, you don't need to do anything. Otherwise, you need to check the system.

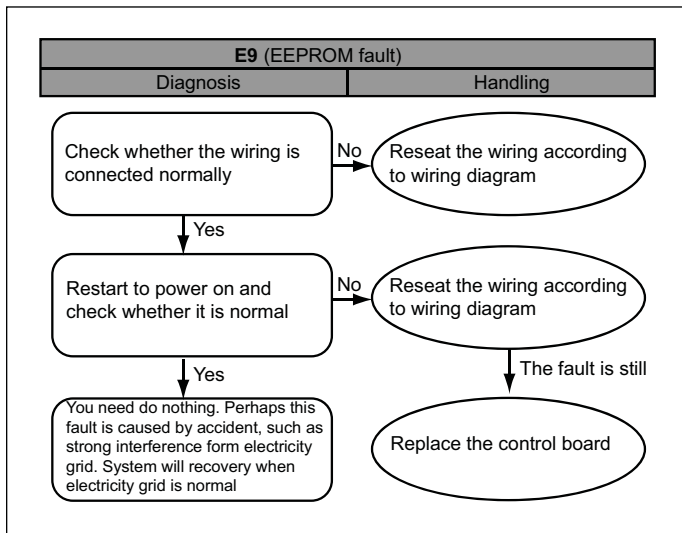

Figure 59

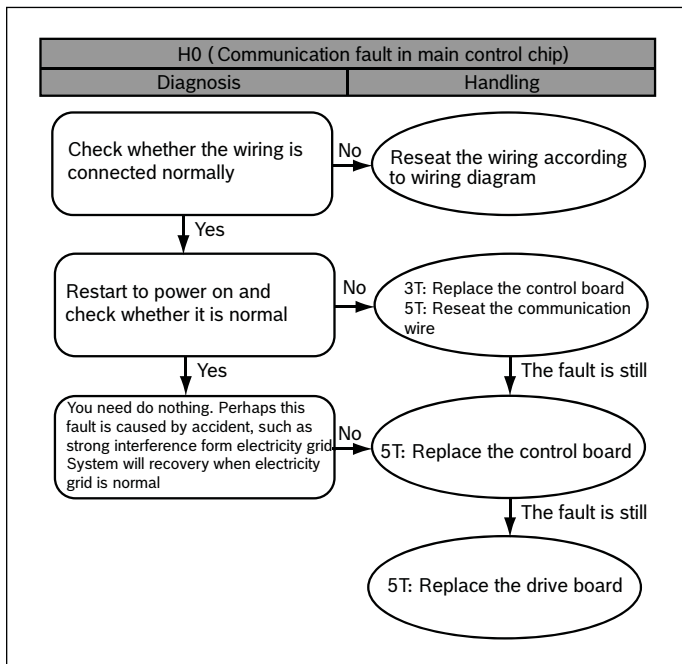

Figure 60

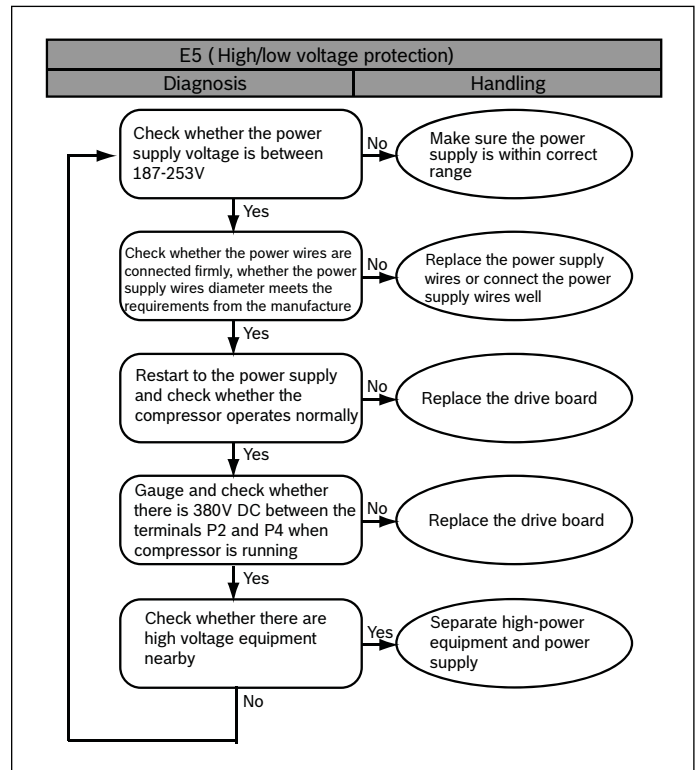

Figure 61

Error Code	Description
P6	IPM module protection
H4	System lockup, 3 times (P6/L0-9) protection in 60 minutes
L0-L9	IPM module protection (the same as P6, only for analysis)

Table 22

When P6/L0-L9 appears occasionally, you don't need to do anything, the system will restart automatically after 6 minutes, of course, if you check the system of running, it will be better.

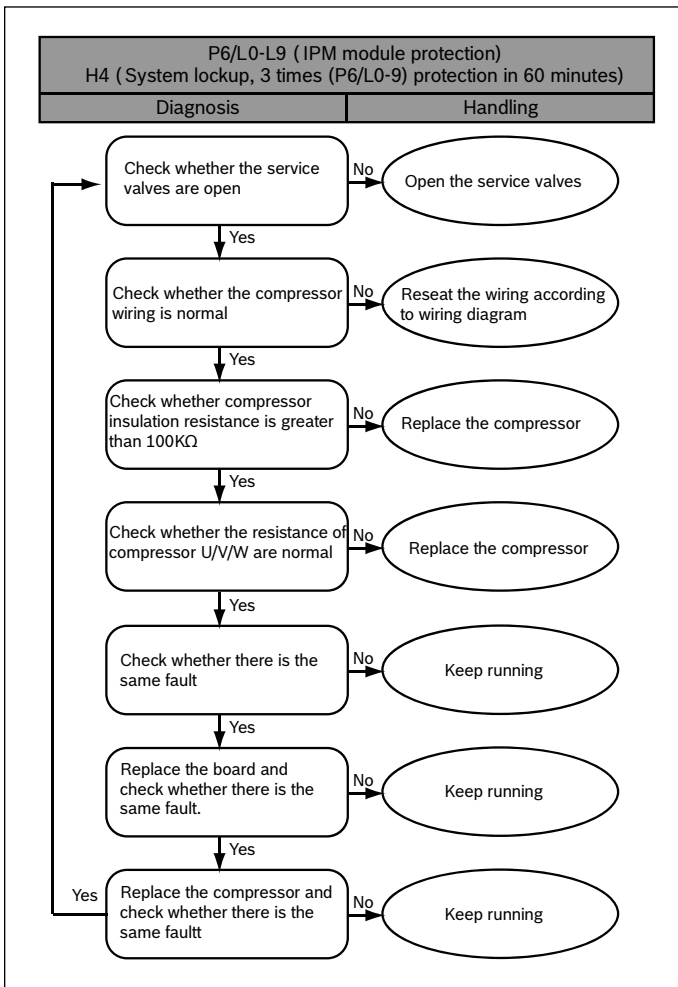

Figure 62

Error Code	Description
AtL	Ambient Temperature Limited

Table 23

i When the ambient temperature returns to within the operating range, the system recovery automatically.

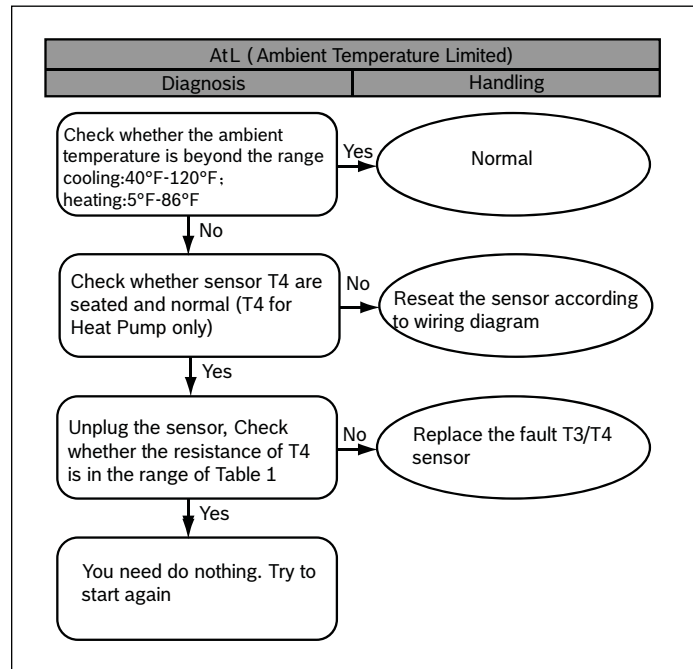

Figure 63

TEMP F	TEMP C	RESISTANCE kΩ	VOLTS DC	TEMP F	TEMP C	RESISTANCE kΩ	VOLTS DC
-5	-20.6	107.732	4.65	90	32.2	7.225	2.36
0	-17.8	93.535	4.6	95	35	6.401	2.21
5	-15	79.521	4.54	100	37.8	5.683	2.07
10	-12.2	67.795	4.47	105	40.6	5.057	1.93
15	-9.4	57.948	4.39	110	43.3	4.509	1.79
20	-6.7	49.652	4.3	115	46.1	4.028	1.67
25	-3.9	42.645	4.21	120	48.9	3.606	1.55
30	-1.1	36.710	4.1	125	51.7	3.233	1.43
40	4.4	27.386	3.86	130	54.4	2.902	1.32
45	7.2	23.732	3.73	135	57.2	2.610	1.22
50	10	20.610	3.59	140	60	2.350	1.13
55	12.8	17.939	3.45	145	62.8	2.119	1.04
60	15.6	15.648	3.3	150	65.6	1.914	0.96
65	18.3	13.681	3.15	155	68.3	1.731	0.88
70	21.1	11.987	2.99	160	71.1	1.574	0.82
75	23.9	10.527	2.83	165	73.9	1.416	0.75
80	26.7	9.265	2.67	170	76.7	1.276	0.68
85	29.4	8.172	2.52				

Table 24

TEMP F	TEMP C	RESISTANCE kΩ	VOLTS DC	TEMP F	TEMP C	RESISTANCE kΩ	VOLTS DC
-5	-20.6	600.134	4.93	140	60	13.643	3.14
0	-17.8	505.551	4.92	145	62.8	12.359	3.03
5	-15	427.463	4.91	150	65.6	11.214	2.91
10	-12.2	362.739	4.89	155	68.3	10.227	2.8
15	-9.4	308.891	4.87	160	71.1	9.308	2.68
20	-6.7	265.398	4.85	165	73.9	8.485	2.56
25	-3.9	227.481	4.83	170	76.7	7.746	2.45
30	-1.1	195.601	4.8	175	79.4	7.105	2.34
35	1.7	168.707	4.77	180	82.2	6.504	2.23
40	4.4	146.695	4.74	185	85	5.963	2.13
45	7.2	127.258	4.7	190	87.8	5.474	2.02
50	10	110.707	4.66	195	90.6	5.032	1.92
55	12.8	96.572	4.61	200	93.3	4.645	1.83
60	15.6	84.465	4.56	205	96.1	4.28	1.73
65	18.3	74.411	4.51	210	98.9	3.949	1.64
70	21.1	65.408	4.45	215	101.7	3.648	1.56
75	23.9	57.634	4.39	220	104.4	3.383	1.48
80	26.7	50.904	4.32	225	107.2	3.133	1.4
85	29.4	45.258	4.24	230	110	2.904	1.32
90	32.2	40.152	4.16	235	112.8	2.694	1.25
95	35	35.699	4.08	240	115.6	2.503	1.18
100	37.8	31.807	3.99	245	118.3	2.334	1.12
105	40.6	28.398	3.89	250	121.1	2.172	1.06
110	43.3	25.506	3.8	255	123.9	2.024	1
115	46.1	22.861	3.7	260	126.7	1.888	0.95
120	48.9	20.529	3.59	265	129.4	1.767	0.9
125	51.7	18.47	3.48	270	132.2	1.651	0.85
130	54.4	16.708	3.37	275	135	1.544	0.8
135	57.2	15.085	3.26	280	137.8	1.446	0.76

Table 25

NSK-BD035I				V = (7.9*PSIG*10-3)+0.5				
No.	V	Pe/Pc	No.	V	Pe/Pc	No.	V	Pe/Pc
		PSIG			PSIG			PSIG
1	0.69	24.4	56	1.37	110.6	111	2.54	258.5
2	0.7	26.0	57	1.39	112.5	112	2.56	262.0
3	0.72	27.7	58	1.4	114.5	113	2.59	265.6
4	0.73	29.4	59	1.42	116.5	114	2.62	269.2
5	0.75	31.2	60	1.43	118.6	115	2.65	272.8
6	0.76	33.1	61	1.45	120.6	116	2.68	276.5
7	0.78	35.0	62	1.47	122.7	117	2.71	280.2
8	0.79	37.0	63	1.48	124.8	118	2.74	284.0
9	0.81	39.0	64	1.5	127.0	119	2.77	287.8
10	0.82	41.1	65	1.52	129.1	120	2.8	291.6
11	0.84	43.2	66	1.53	131.3	121	2.83	295.5
12	0.85	44.3	67	1.55	133.5	122	2.86	299.3
13	0.86	45.4	68	1.57	135.8	123	2.89	303.3
14	0.87	46.6	69	1.59	138.0	124	2.92	307.2
15	0.88	47.7	70	1.61	140.3	125	2.95	311.3
16	0.89	48.9	71	1.62	142.6	126	2.98	315.3
17	0.89	50.0	72	1.64	145.0	127	3.02	319.4
18	0.9	51.2	73	1.66	147.3	128	3.05	323.5
19	0.91	52.4	74	1.68	149.7	129	3.08	327.7
20	0.92	53.7	75	1.7	152.1	130	3.12	331.9
21	0.93	54.9	76	1.72	154.6	131	3.15	336.1
22	0.94	56.2	77	1.74	157.1	132	3.18	340.4
23	0.95	57.5	78	1.76	159.6	133	3.22	344.7
24	0.96	58.8	79	1.78	162.1	134	3.25	349.0
25	0.97	60.1	80	1.8	164.6	135	3.29	353.4
26	0.98	61.4	81	1.82	167.2	136	3.32	357.9
27	0.99	62.8	82	1.84	169.8	137	3.36	362.4
28	1.01	64.1	83	1.86	172.5	138	3.39	366.9
29	1.02	65.5	84	1.88	175.1	139	3.43	371.4
30	1.03	66.9	85	1.9	177.8	140	3.46	376.0
31	1.04	68.4	86	1.92	180.5	141	3.5	380.7
32	1.05	69.8	87	1.94	183.3	142	3.54	385.4
33	1.06	71.3	88	1.97	186.1	143	3.57	390.1
34	1.07	72.7	89	1.99	188.9	144	3.61	394.9
35	1.09	74.3	90	2.01	191.7	145	3.65	399.7
36	1.1	75.8	91	2.03	194.6	146	3.69	404.5
37	1.11	77.3	92	2.06	197.5	147	3.73	409.5
38	1.12	78.9	93	2.08	200.4	148	3.77	414.4
39	1.13	80.5	94	2.1	203.4	149	3.8	419.4
40	1.15	82.1	95	2.13	206.4	150	3.84	424.4
41	1.16	83.7	96	2.15	209.4	151	3.88	429.5
42	1.17	85.3	97	2.17	212.4	152	3.93	434.6
43	1.19	87.0	98	2.2	215.5	153	3.97	439.8
44	1.2	88.7	99	2.22	218.6	154	4.01	445.0
45	1.21	90.4	100	2.25	221.8	155	4.05	450.3
46	1.23	92.1	101	2.27	224.9	156	4.09	455.6
47	1.24	93.8	102	2.3	228.1	157	4.13	461.0
48	1.25	95.6	103	2.32	231.4	158	4.18	466.4
49	1.27	97.4	104	2.35	234.6	159	4.22	471.9
50	1.28	99.2	105	2.38	238.0	160	4.26	477.4
51	1.3	101.0	106	2.4	241.3	161	4.31	482.9
52	1.31	102.9	107	2.43	244.7	162	4.35	488.6
53	1.33	104.8	108	2.45	248.1	163	4.39	494.2
54	1.34	106.7	109	2.48	251.5	164	4.44	499.9
55	1.36	108.6	110	2.51	255.0	165	4.48	505.7

Table 26

16 Wiring diagrams

16.1 For BOVA 36

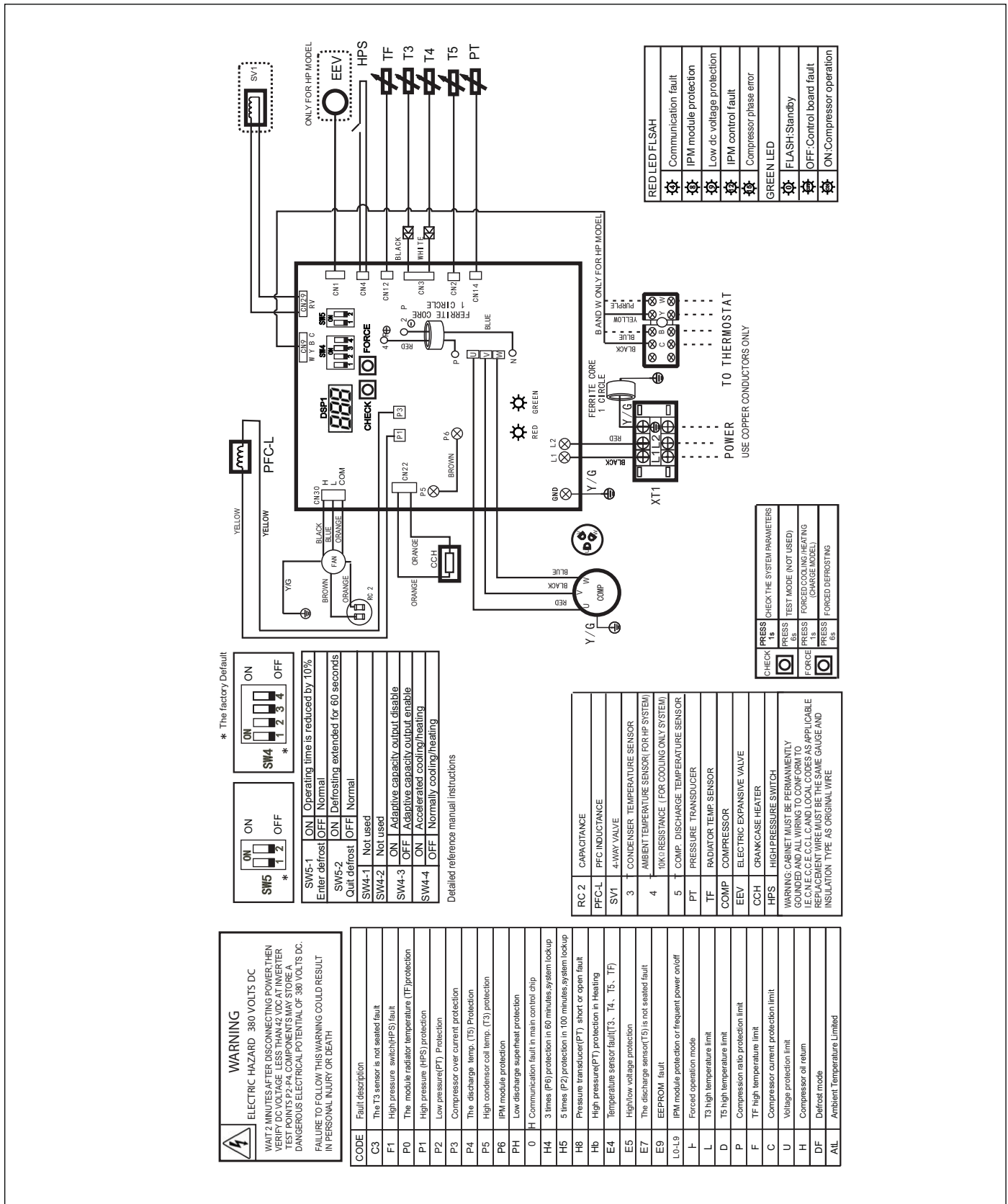
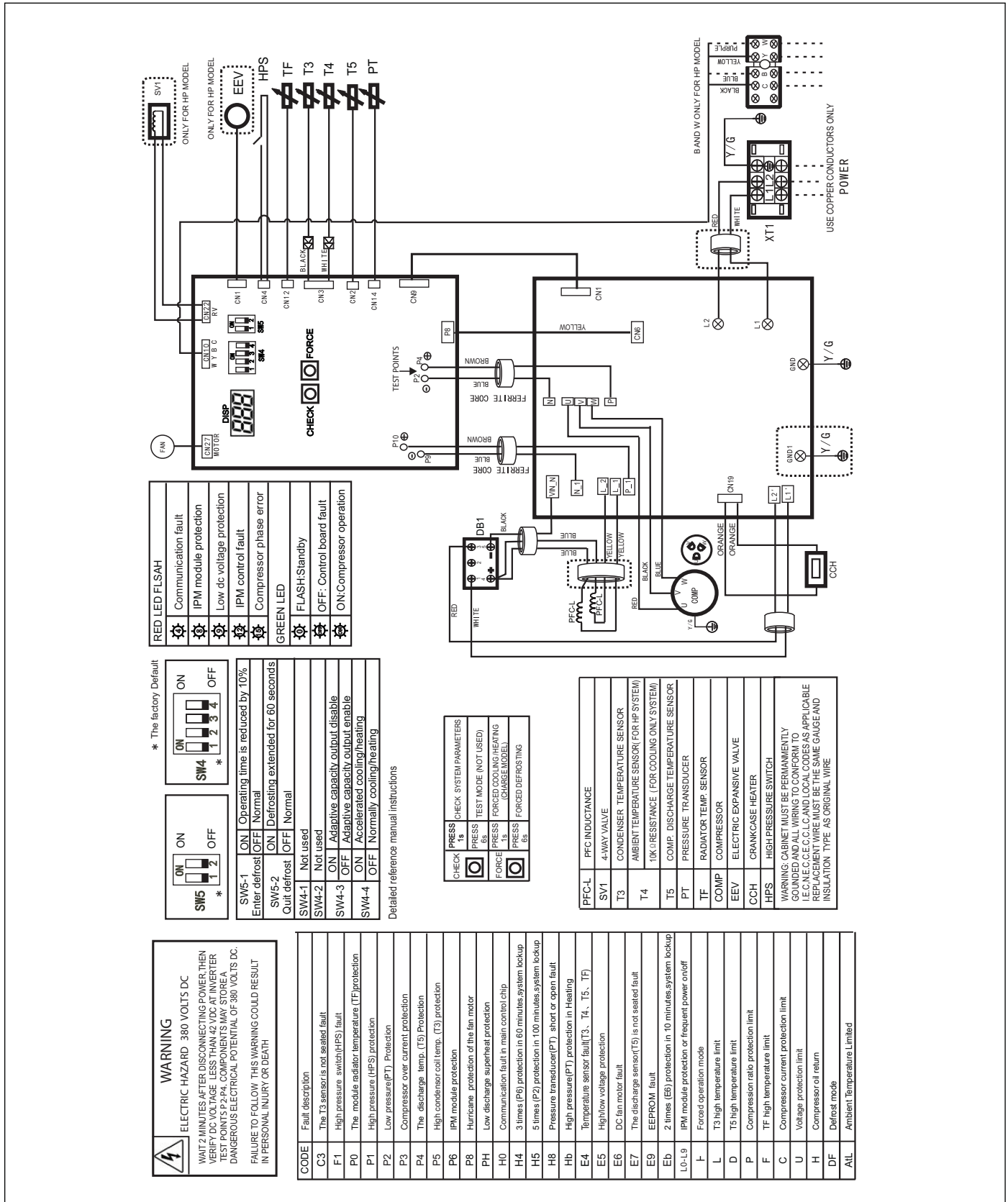

Figure 64

16.2 For BOVA 60



	RED LED FLSAH
	Communication fault
	IPM module protection
	Low dc voltage protection
	IPM control fault
	Compressor phase error
	GREEN LED
	FLASH: Standby
	OFF: Control board fault
	ON: Compressor operation

* The factory Default

	SW5	ON	OFF
	SW4	ON	OFF

SW5-1 ON Operating time is reduced by 10%
 SW5-2 ON Defrosting time is reduced by 10%
 SW5-3 ON Defrosting time is reduced by 10%
 SW5-4 ON Defrosting time is reduced by 10%

SW4-1	Not used
SW4-2	Not used
SW4-3	ON Adaptive capacity output disable OFF Adaptive capacity output enable
SW4-4	ON Accelerated cooling/heating OFF Normally cooling/heating

	CHECK	1s	CHECK SYSTEM PARAMETERS
	PRESS	6s	TEST MODE (NOT USED)
	FORCE	1s	FORCED COOLING/HEATING (CHARGE MODEL)
	FORCE	6s	FORCED DEFROSTING

WARNING
 ELECTRIC HAZARD 380 VOLTS DC
 WAIT 2 MINUTES AFTER DISCONNECTING POWER THEN VERIFY VOLTAGE LESS THAN 42 VDC AT INVERTER TERMINALS. DANGEROUS ELECTRICAL POTENTIAL OF 380 VOLTS DC. FAILURE TO FOLLOW THIS WARNING COULD RESULT IN PERSONAL INJURY OR DEATH

CODE	Fault description
C3	The T3 sensor is not seated fault
F1	High pressure switch(HPS) fault
P0	The module radiator temperature (TP) protection
P1	High pressure (HPS) protection
P2	Low pressure(PT) Protection
P3	Compressor over current protection
P4	The discharge temp. (T5) Protection
P5	High condensor coil temp. (T3) protection
P6	IPM module protection
P8	Hurricane protection of the fan motor
PH	Low discharge superheat protection
H0	Communication fault in main control chip
H4	3 times (P6) protection in 60 minutes system backup
H5	5 times (P2) protection in 100 minutes system backup
H8	Pressure transducer(PT) short or open fault
Hb	High pressure(PT) protection in Heating
E4	Temperature sensor fault(T3, T4, T5, TF)
E5	High/low voltage protection
E6	DC fan motor fault
E7	The discharge sensor(T5) is not seated fault
E9	EEPROM fault
Eb	2 times (E6) protection in 10 minutes system backup
L0-L9	IPM module protection or frequent power on/off
F	Forced operation mode
L	T3 high temperature limit
D	T5 high temperature limit
P	Compression ratio protection limit
F	TF high temperature limit
C	Compressor current protection limit
U	Voltage protection limit
H	Compressor oil return
DF	Defrost mode
AIL	Ambient Temperature Limited

PFCL	PFC INDUCTANCE
SV1	4-WAY VALVE
T3	CONDENSER TEMPERATURE SENSOR
T4	AMBIENT TEMPERATURE SENSOR(FOR HP SYSTEM)
T5	10K-Ω RESISTANCE (FOR COOLING ONLY SYSTEM)
PT	COMP. DISCHARGE TEMPERATURE SENSOR
TF	RADIATOR TEMP. SENSOR
COMP	COMPRESSOR
EEV	ELECTRIC EXPANSIVE VALVE
CCH	CRANKCASE HEATER
HPS	HIGH PRESSURE SWITCH

WARNING: CABINET MUST BE PERMANENTLY GOUNDED AND ALL WIRING TO CONFORM TO I.E.C.N.E.C.C.C.L.C. AND LOCAL CODES AS APPLICABLE. REPLACEMENT WIRE MUST BE THE SAME GAUGE AND INSULATION TYPE AS ORIGINAL WIRE.

Figure 65

17 Spare parts

17.1 For BOVA 36

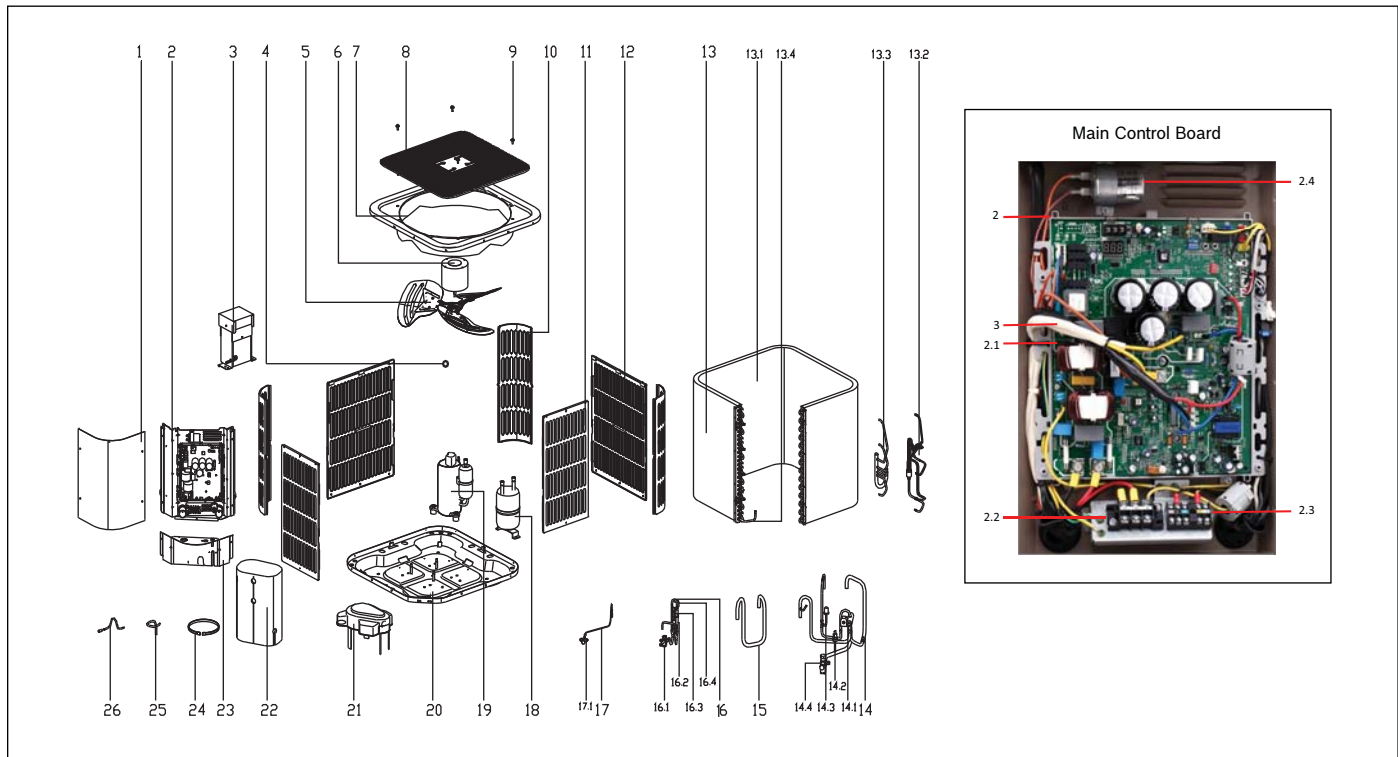

Figure 66

No.	Part Name	Qty	BOVA 36 (3 Ton)	No.	Part Name	Qty	BOVA 36 (3 Ton)
1	Upside board ass'y	1	8733941794	16	High pressure valve Ass'y	1	8733941821
2	E-part box ass'y	1	8733941795	16.1	Block valve	1	8733941822
2.1	Main control board ass'y	1	8733941796	16.2	One way valve	1	8733941823
2.2	Wire joint	1	8733941797	16.3	Electronic expansion valve body	1	8733941824
2.3	Wire joint, 5p	1	8733941798	16.4	EEV solenoid wire rings	1	8733941825
2.4	Capacitor for fan motor	1	8733941799	17	meter connector ass'y	1	8733941826
3	E-part box ass'y	1	8733941800	17.1	Pipe joint	1	8733941827
4	Nut	1	8733941801	18	Gas-liquid separator	1	8733941828
5	Fan	1	8733941802	19	Compressor	1	8733941829
6	Motor	1	8733941803	20	Chassis Parts	1	8733941830
7	Top cover ass'y	1	8733941804	21	Rubber Cap	1	8733941831
8	Top cover veil	1	8733941805	22	Soundproof cotton	1	8733941832
9	Bolt and washer assembly	4	8733941806	23	Rear clapboard ass'y	1	8733941833
10	Supporting board	3	8733941807	24	Compressor electric heater (with spring)	1	8733941834
11	Clapboard ass'y 1	2	8733941808	25	Compressor Discharge Temp. sensor ass'y	1	8733941835
12	Clapboard ass'y 2	2	8733941809	26	Condenser Pipe Temp. sensor ass'y	1	8733941836
13	Condenser components	1	8733941810				
13.1	Condenser	1	8733941811				
13.2	Condenser output pipe ass'y	1	8733941812				
13.3	Condenser input pipe ass'y	1	8733941813				
13.4	Condenser connection pipe ass'y	1	8733941814				
14	4-way valve ass'y	1	8733941815				
14.1	4-way valve ass'y	1	8733941816				
14.2	Pressure sensor	1	8733941817				
14.3	Pressure controller	1	8733941818				
14.4	Block valve	1	8733941819				
15	Suction pipe ass'y	1	8733941820				

Table 27

17.2 For BOVA 60

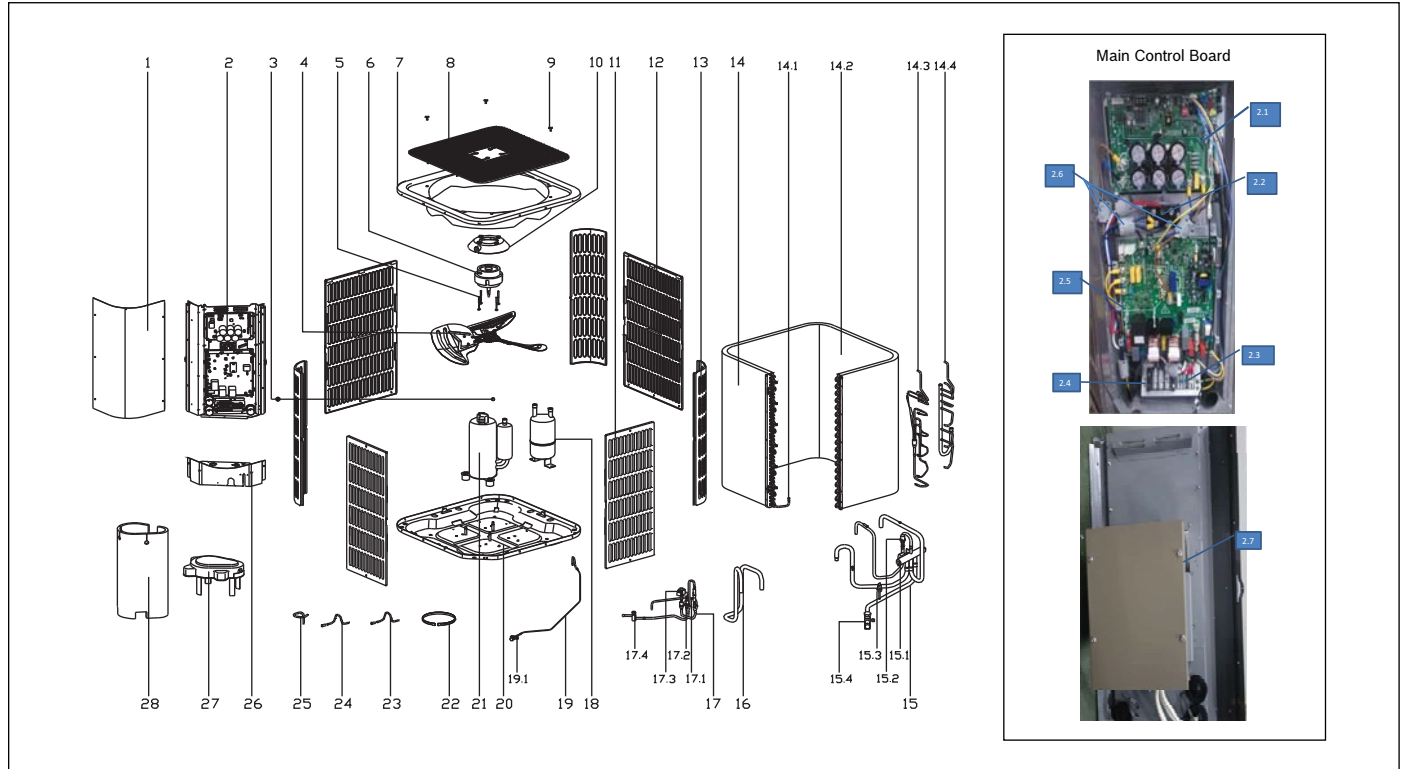

Figure 67

No.	Part Name	Qty	BOVA 60 (5 Ton)	No.	Part Name	Qty	BOVA 60 (5 Ton)
1	Side board ass'y	1	8733941837	15.2	Pressure controller	1	8733941857
2	E-part box ass'y	1	8733941838	15.3	Pressure sensor	1	8733941817
2.1	Main control board ass'y	1	8733941839	15.4	Block valve	1	8733941858
2.2	Three phase bridge	1	8733941840	16	Suction pipe ass'y	1	8733941859
2.3	Wire joint, 5p	1	8733941798	17	High-pressure valve ass'y	1	8733941860
2.4	Wire joint, 3p	1	8733941841	17.1	One way valve	1	8733941823
2.5	Main control board ass'y	1	8733941842	17.2	Electronic expansion valve body	1	8733941861
2.6	EMC Solenoid	4	8733941843	17.3	EEV solenoid wire rings	1	8733941862
2.7	Electric reactor	2	8733941844	17.4	Block valve	1	8733941822
3	Nut	1	8733941801	18	Gas-liquid separator	1	8733941863
4	Fan	1	8733941802	19	meter connector ass'y	1	8733941864
5	Electrical installation bolt	4	8733941845	19.1	Pipe joint	1	8733941827
6	BLDC	1	8733941846	20	Chassis Parts	1	8733941830
7	Top conveer ass'y	1	8733941804	21	Compressor	1	8733941865
8	Top cover veil	1	8733941805	22	Compressor electric heater (with spring)	1	8733941866
9	Bolt and washer assembly	4	8733941806	23	Compressor Discharge Temp. sensor ass'y	1	8733941867
10	Motor installation board ass'y	1	8733941847	24	Condenser Pipe Temp. sensor ass'y	1	8733941868
11	Side board ass'y 2	2	8733941848	25	Ambient Temp. sensor ass'y	1	8733941869
12	Side board ass'y	2	8733941849	26	Rear clapboard ass'y	1	8733941833
13	Supporting board	3	8733941850	27	Rubber Cap	1	8733941831
14	Condenser ass'y	1	8733941851	28	Soundproof cotton	1	8733941870
14.1	Condenser connection pipe ass'y	1	8733941814				
14.2	Condenser	1	8733941852				
14.3	Condenser outlet pie ass'y	1	8733941853				
14.4	Condenser inlet pie ass'y	1	8733941854				
15	4-way valve ass'y	1	8733941855				
15.1	4-way valve ass'y	1	8733941856				

Table 28

Notes:

Notes:

Notes:

United States and Canada

Bosch Thermotechnology Corp.
50 Wentworth Avenue
Londonderry, NH 03053

Tel: 866-642-3198
Fax: 954-776-5529
www.boschheatingandcooling.com