



Builder's Best, Inc.
 201 Broiles Drive
 Jacksonville, TX 75766
 888-368-7233
 fax: 800-259-8368
 www.BuilderBest.com

HEAVY GAUGE GALVANIZED HOODS WITH FLAPPER & SCREEN



PRODUCT SPECIFICATIONS

- 26 gauge galvanized steel
- Mouth opening exceeds pipe area for best airflow
- ¼" x ¼" screens mechanically inserted and removable
- Back Draft Flapper
- Available without tailpipe, with 6" tailpipe or 11" tailpipe
- 4 mounting holes for secure connections

PART NUMBERS

Diameter	Part #	Qty	A (in.)	B (in.)	C (in.)	D (in.)
4"	111229	20	7.5	3.25	6	n/a
	111033	12	7.5	3.25	6	6
	011023	12	7.5	3.25	6	11
5"	111231	12	9	4	8	n/a
	111035	12	9	4	8	6
	111024	6	9	4	8	11
6"	111233	12	9	4	8	n/a
	111037	12	9	4	8	6
	111026	6	9	4	8	11
7"	111235	12	11.25	5.4	10	n/a
	111038	10	11.25	5.4	10	6
	111027	6	11.25	5.4	10	11
8"	111237	12	11.25	5.4	10	n/a
	111039	10	11.25	5.4	10	6
	111028	6	11.25	5.4	10	11
10"	111239	2	14.13	6.9	12	n/a
	111040	2	14.13	6.9	12	6
	011029	1	14.13	6.9	12	11
12"	111241	2	14.13	6.9	14	n/a
	111041	2	14.13	6.9	14	6
	011030	1	14.13	6.9	14	11

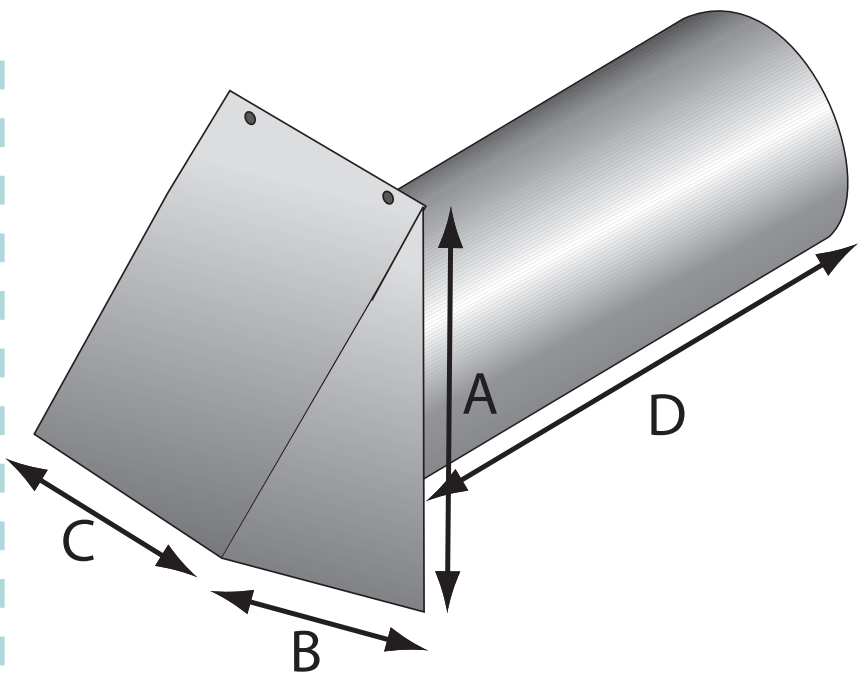

LABELS



Made in the U.S.A.

WARRANTY

Manufacturer assumes no responsibility for failure due to improper installation. All specifications and designs are subject to change without notice and without incurring liability.

WARRANTY EXCLUSION AND DISCLAIMER Seller specifically excludes, and hereby disclaims any express representation or express warranty of any kind with respect to the goods ordered hereunder. All implied warranties, including without limitation merchantability or fitness for a particular purpose or arising from a course of dealing or usage or trade shall expire and cease 45 days after date of delivery. Seller shall not be liable to buyer or any third party for any special, secondary, incidental, or consequential damages however arising. Nothing in this provision shall invalidate or restrict any right or remedy otherwise available under state or federal law. Materials and specifications subject to change without notice.

Heavy Gauge Galvanized Hoods with Flapper and Screen V2 12/11/14