

SIDE MOUNT UNDERCOUNTER REFRIGERATOR

Side Mounted Condensing Unit



ET – Series Model : ETR3

WARRANTY

5 YEAR Compressor

3 YEAR Parts & Labor



Operating temperature range is 32°F ~ 42°F

Cabinet Construction

Heavy duty stainless steel interior and exterior, with galvanized steel finished bottom and back wall of exterior. High quality 16 gauge stainless steel worktop. 2.5" thick high density foamed-in-place polyurethane insulation. Four 4" diameter casters (front casters with brakes). Door heater installed around inside cabinet frame to prevent moisture build-up.

Refrigeration System

- Side mounted condensing unit for extra interior space compared to back mounted units
- Oversized condenser and evaporator coils quickly achieve and maintain desired temperature
- Forced-air cooling with oversized evaporator fan motors providing balanced airflow throughout cabinet to ensure faster temperature drop
- Removable side panel and slide-out condensing unit for convenient repair and maintenance
- Removable condenser coil air filter for easy cleaning
- Environmentally friendly CFC free R-134A refrigerant
- Air defrost, time initiated and terminated
- Copper tube and aluminum fin evaporator with anti-corrosive coating
- Energy efficient condensate drain pan assembly heated by high side copper tube
- Pressure relief port for rapid cabinet re-entry
- Pre-wired and ready to plug, 115V/60Hz/1Ph, NEMA 5-15P

Doors

- Heavy duty stainless steel interior and exterior
- 2.5" thick foamed-in-place polyurethane insulation
- Rounded corners for a sleek and modern appearance
- Heavy duty adjustable torsion spring self-closing door system
- One piece snap-in magnetic door gaskets for easy replacement
- Heavy duty recessed door handles for a flat surface
- All 2015 and newer models come standard with door locks

Lighting

- Shielded incandescent interior lighting

Shelving

- Two epoxy coated wire shelves per section
- Stainless steel pilasters and shelf clips

Temperature Control

- Factory preset temperature, 35°F
- Setting temperature range from 33°F to 54°F
- Easy to read digital temperature display
- Easy to program push button temperature control
- Microchip digital control and monitoring system with a variety of functions to monitor and maintain optimum temperature

Options

- 4" high stainless steel backsplash for worktop use
- 2 1/2" diameter casters (3 1/2" overall height)

Contact

201 W. Artesia Blvd, Compton, CA 90220
 T. (310) 323-6586, (800) 444-6285 F. (310) 323-7524, (310) 761-1127



Please visit our website for updated Energy Efficiency information

Model	# of Doors	Capacity (Cu. Ft.)	HP	Refrigerant	# of Shelves	Power (V-Hz-Ph)	Amps	Crated Weight	Exterior Dimensions		
									L	D	H*
ETR3	3	22	1/3	R-134A	6	115-60-1	5.24	353lbs (160.1kg)	71 1/8" (1806 mm)	31 1/2" (800 mm)	29 1/4" (742 mm)

Product dimensions are for general purposes and not absolute value. Product capacity is calculated based on standard industry figures. Slight variations may exist. If dimensions and capacity are critical, please contact Everest Refrigeration.

*: Height does not include 5" for casters

SIDE MOUNT UNDERCOUNTER REFRIGERATOR

Side Mounted Condensing Unit



EVEREST
REFRIGERATION
www.EVERESTref.com

ET – Series Model : ETR3

DIMENSIONAL DATA		
Net capacity cu. ft.		22 (623 cu l)
Exterior (mm)	Length Overall in.	71 1/8" (1806)
	Depth Overall in.	31 1/2" (800)
	Height Overall in.*	29 1/4" (742)
Interior (mm)	Length Overall in.	57 1/8" (1450)
	Depth Overall in.	26 3/4" (680)
	Height Overall in.	24" (610)
Crated Weight	353lbs (160.1kg)	
# of Doors	3	
# of Shelves	6	
Shelf Size Length x Depth in. (mm)	18 1/8" x 24 3/8" (460 x 620)	
	19 1/4" x 24 3/8" (490 x 620)	
ELECTRICAL DATA		
Voltage (V-Hz-Ph)	115-60-1	
Full load amperes	5.24	
Feed wires with Ground	3	
Cord Length ft.	9	
REFRIGERATION DATA		
Refrigerant	R-134A	
Compressor H.P.	1/3 HP	
BTU/HR† (Kcal/h)	2555 (644)	

Specifications subject to change without notice.

- *: Height does not include 5" for casters.
- †: Based on evaporating temperature of 23°F(-5°C) & Condensing temperature of 131°F(55°C).

Equipped With One NEMA 5-15P Plug



Dimensions (mm)

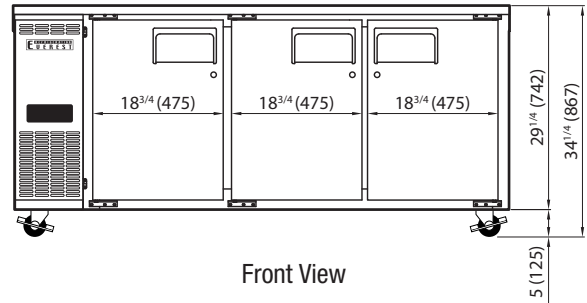

Front View

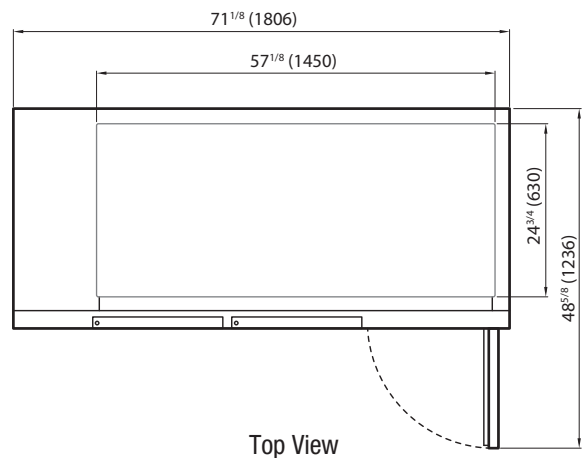

Top View

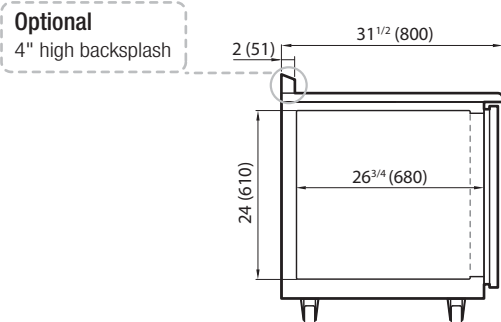

Side View

• Project / Customer _____

• Item No. _____

• Quantity _____

Warranty

5 Year — Compressor Warranty
3 Year — Parts & Labor Warranty

Contact

201 W. Artesia Blvd, Compton, CA 90220
T. (310) 323-6586, (800) 444-6285
F. (310) 323-7524, (310) 761-1127