



Ice storage and transport system

with gravity dispense cart loading

Features

Designed with speed, safety and sanitation in mind

- elevated ice storage bin uses gravity to dispense ice through a chute 15 times faster than scooping
- one pull of the gate bar fills the SmartCART™ 240 ice cart with 200 lb (91 kg) of ice without any hand contact
- dispensing directly into cart eliminates scooping by hand to help prevent cross-contamination
- cart reduces the risk of back injuries by eliminating carrying containers of ice
- optional Totes™ ice carriers may be ordered – SmartCART 240 will hold 6 Totes for use in applications where the ice needs to be lifted out of the SmartCART 240
- industry exclusive SmartGATE® ice shield controls the flow of ice to reduce spills and limit contact with ice

Fresher ice

- first ice in is first ice out

Ice compatibility

- Compatible with cube ice, flake ice and customer-preferred Chewblet® ice

Durable, user friendly construction

- full stainless bin exterior and base
- corrosion-resistant poly bin liner and custom-cut stainless steel top
- heavy duty “stay-open” PowerHinge™ door hinge – easy one hand open and close without door catches

SmartCART 240 insulated all-poly carts

- cart drains to bin system when parked in bay

Includes:

- one, two or three SmartCART 240 ice transport cart(s) depending on model
- paddle with hanging bracket

Accessories

Set of 6 Totes ice carriers (Totes not standard)
(item# ABICETOTP)

Additional carts and accessories (refer to form# 3435)

Gravity ice dispense eliminates scooping

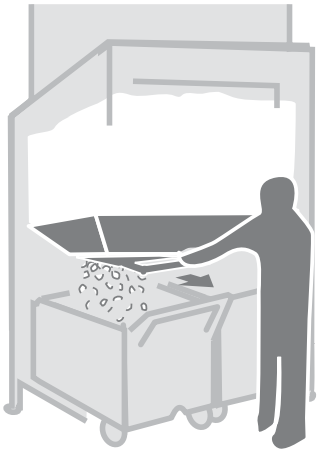

Job

Item

Follett Europe Polska Sp. z o.o.
Mokry Dwór 26C 83-021 Wiślina, Poland
+48 (58) 785-6140 | Fax: +48 (58) 785-6159
folletteurope.com

801 Church Lane | Easton, PA 18040, USA
1.610.252.7301 | Fax: +1.610.250.0696 | follette.com

FOLLETT[®]
Innovative solutions, inspired by ice

Specification

Maximum bin capacity ¹	see model table below
W1 Bin width	see model table below
D1 Bin depth ³	see model table below
D2 Bin depth with door closed	48.00" (121.9 cm)
D3 Bin depth with door fully extended	58.50" (148.6 cm)
H1 Bin height (adjustable) ⁴	see model table below
H2 Bin base height (adjustable)	38.75" (98.4 cm)
Required door access	see model table below
W2 Cart width	24.50" (62.2 cm)
D4 Cart depth	41.50" (105.4 cm)
H4 Cart height at front edge	35.83" (91.0 cm)
H5 Cart height at rear edge	28.74" (73.0 cm)
W3 Tote width	15.62" (39.7 cm)
D5 Tote depth	7.12" (18.08 cm)
H6 Tote height	15.00" (38.1 cm)
Temperature range	60 - 90 F (16 - 32 C)
C1 Drain ⁶	1.25" ID PVC female slip fit (reversible to opposite side)
Dispense rate	up to 5 lb (2.3 kg) per second
Ice compatibility	cube ice, flake ice and Chewblet ice
Shipping weight	see model table below
NOTE: For indoor use only	

SHORT FORM SPECIFICATION: Ice transport system to be Follett model _____ equipped with SmartCART 240 ice transport cart(s). Elevated bin to hold approximately _____ lb (kg) of ice. Exterior of bin and base to be full stainless steel. All bins (except ITS500NS) to have polyethylene ice access door assembly, polyethylene lift door with PowerHinge door hinge, and SmartGATE ice shield. Stainless steel bin top to be custom-cut for ice machine(s) to be used. Bin liner walls to be of non-corroding polyethylene and insulated with non-CFC foam polyurethane. Bin hopper to be of polyethylene with extra large opening(s) to facilitate ice flow. Base to have built-in drains for bins and carts, and insulated drain troughs, shutter door, and drain to minimize condensation. Cart(s) to be of insulated one-piece molded polyethylene, with plastic lid, four heavy-duty casters (two swivel with one step-on lock and two non-swivel). Carts and optional Totes ice carriers to store below bin when not in use and to drain when positioned in bay. All models to have adjustable flanged feet and paddle. NSF listed.

Warranty:

Follett Corporation warrants to the original purchaser that the cabinet exterior, including the top and trim, and the interior liner will be free of corrosion for 5 years from the date of installation. Date of installation shall not exceed 90 days from date of shipment. Parts and labor for corrosion repair within this 5 year period are covered under this warranty. All other integral components are covered against defects in material and workmanship under normal use and service for a period of 5 years from the date of installation. Date of installation shall not exceed 90 days from date of shipment. Parts and labor for repair within this 5 year period are covered under this warranty. Removal of ice machine to service bin and any labor costs incurred are expressly excluded from this warranty.

Model	Number of carts	Maximum bin capacity ¹ lb (kg)	Maximum capacity with cart(s) ² lb (kg)	Cubic Volume cu ft (m)	Width - W1 in (cm)	Depth ³ - D1 in (cm)	Height ⁴ - H1 in (cm)	Required door access ⁵ in (cm)	Approximate ship weight lb (kg)
ITS500NS-31	1	382 (174)	622 (283)	12.70 (0.36)	31.00 (78.7) ⁵	40.00 (101.6)	60.00 (152.4)	32.00 (81.3)	371 (169)
ITS700SG-31	1	652 (296)	892 (405)	21.70 (0.61)	31.00 (78.7) ⁵	40.00 (101.6)	75.00 (190.5)	32.00 (81.3)	398 (181)
ITS1350SG-60	2	1327 (603)	1567 (712)	44.20 (1.25)	60.00 (152.4) ⁵	40.00 (101.6)	75.00 (190.5)	41.00 (104.1)	712 (323)
ITS2250SG-60	2	2133 (968)	2373 (1077)	71.10 (2.01)	60.00 (152.4) ⁵	40.00 (101.6)	97.00 (246.4)	41.00 (104.1)	822 (373)
ITS1700SG-90	3	1716 (779)	1986 (901)	58.20 (1.65)	90.00 (228.6) ⁵	40.00 (101.6)	70.00 (177.8)	41.00 (104.1)	978 (444)
ITS3250SG-90	3	3255 (1477)	3495 (1586)	108.50 (3.07)	90.00 (228.6) ⁵	40.00 (101.6)	97.00 (246.4)	41.00 (104.1)	1145 (519)

Notes:

- ¹ Computed on cubic volume of bin. Does not reflect cart capacity or voids that can occur due to pyramiding.
- ² Each cart holds 240 lb (109 kg) without optional Totes ice carriers, 150 lb (68 kg) with Totes ice carriers.
- ³ Add 8.00" (20.32 cm) to depth (D) for lower door assembly (easily removed for installation access).
- ⁴ Special top required for ice machines weighing more than 1000 lb (454 kg). Add 2.12" (5.38 cm) to height. Contact factory.
- ⁵ Required clearance for installation access through doors (may require removal of door assembly).
- ⁶ Follett recommends installation of a floor drain with grate with all ice storage bins. Consider cart positioning when locating the drain. Clearance required to pull cart from below bin — minimum 42.00" (106.7 cm), optimal 56.00" (142.2 cm).

Dimensional drawing

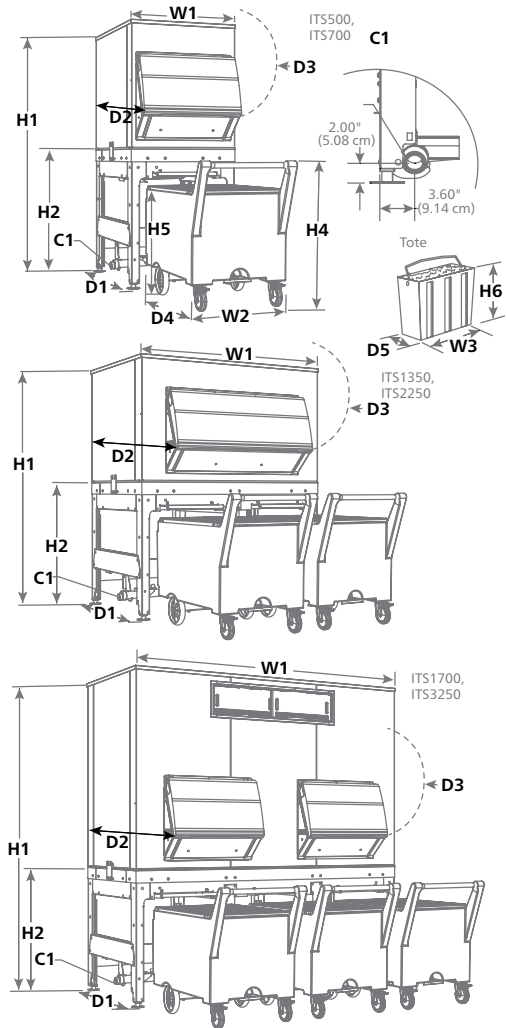

PowerHinge, SmartCART and Totes are trademarks of Follett Corporation. Chewblet, Follett and SmartGATE are registered trademarks of Follett Corporation, registered in the US. Follett reserves the right to change specifications at any time without obligation. Certifications may vary depending on country of origin.