

Submittal Data: CROWN18HP230V1B 18,000 BTU/H Wall Mounted Heat- Pump System

Job Name _____ Location _____ Date _____

Purchaser _____ Engineer _____

Submitted To _____ For Reference Approval Construction

Unit Designation _____ Schedule No. _____

- GENERAL FEATURES**
- Variable Speed (Inverter) Two-Stage Compressor
 - Low Ambient Heating (down to -22° F)
 - Wi Fi Controls
 - 7 Indoor Fan Speeds
 - 4 Way Airflow Operation
 - Wireless Remote with LCD Display
 - I-FEEL Function
 - 5 year Limited Parts Warranty



System Ratings **Indoor Unit Data**

Cooling	
Rated Capacity	18,000 BTU/H
Capacity Range	4,436 -21,496 BTU/H
Power Input (Max)	2,400 W
SEER	21.0
EER	12.5

Fan Motor	Type	Cross-flow
	Output Power	20 W
	FLA	0.2 A
Airflow	(Low/High)	324/530 CFM
Air Throw	(Max)	29.5 ft
Sound Pressure Level		
	Cooling (Low/High)	26/48 db(A)
	Heating (Low/High)	26/48 db(A)
Dehumidification		3.8 pt/hr

Heating at 47° F	
Rated Capacity	19,000 BTU/H
Capacity Range	3,753 -24,566 BTU/H
Power Input (Max)	2,500 W
HSPF	10.5
COP	3.1

Outdoor Unit Data

Compressor	Type	DC Inverter Driven 2-Stage Rotary
	FLA	14.5A
Fan Motor	Output Power	90 W
	FLA	0.65 A
Sound Pressure		59 db(A)

Heating at 17° F	
Rated Capacity	12,700 BTU/H
Capacity (Max)	19,390 BTU/H
Power Input (Max)	1,973 W
COP	2.1

Refrigerant Piping Data

Gas Pipe Size (OD)	5/8-in
Liquid Pipe Size (OD)	1/4-in
Connection Method	Flared
Factory Charge	R410a/70.6 oz
Additional Charge	0.54 oz/ft
Pre-Charge Length	25-ft
Max Refrigerant Pipe Length	82-ft
Min Refrigerant Pipe Length	10-ft
Min Refrigerant Pipe Height Difference	33-ft

Operating Range		
Cooling	(Max)	129°F (54 C)
	(Min)	0°F (-18 C)
Heating	(Max)	75°F (24 C)
	(Min)	-22°F (-30 C)

Power Supply	
Normal Operational Voltage	208/230 V, 1 Phase, 60 Hz
Voltage Range	187 - 253 V
Main Power Wire Size	10-2 AWG
Interconnecting Cable Wire Size	14-4 AWG
MCA	19 A
MOCP/Breaker Size	30 A

SYSTEM FEATURES	
Inverter Type	G10
Ultra Low Frequency Torque Control	Yes
Power Factor Correction	Yes
Compressor Type	High Eff. Two Stage Rotary
Refrigerant Type	R410A
Basepan With Electric Heater	YES
Compressor With Electric Heater	YES
Outdoor Fin Coating	Bule Fin
Intelligent Defrosting	YES
Intelligent Preheating	YES
Low Voltage Startup	YES
Memory/Power Failure Recovery	YES
Self Diagnosis	YES
Wired Controller Interface	NO
Wi-Fi Interface Capable	YES
Indoor Fan Type	Crossflow
Multi Fan Speeds	7 Speeds
Indoor Unit Display	YES
Advance Filter	Optional (see Filter Kits)
Auxiliary Electrical Heater	NO
Ventilation (Outdoor Air)	NO

REMOTE CONTROLLER FUNCTIONS	
Auto Mode	YES
Auto Fan	YES
Auto Swing (Horizontal Auto Swing)	YES
Auto Swing (Vertical Auto Swing)	YES
Clock on Remote Controller	YES
Dry Mode	YES
Dry Anti-Mildew (X-Fan) Mode	YES
Energy Saving Mode	NO
Dirty Filter Alert	NO
I Feel Function	YES
Lock on Remote Controller	YES
Quiet Mode	YES
Room Temperature Display	NO
Sleep Mode	YES
4 Sleep Modes Options	YES
Timer Mode	YES
Turbo Mode	YES
Display On/Off Control	YES
Freeze Guard Mode	NO
Display On/Off Control	YES
Freeze Guard Mode	YES

COOLING PERFORMANCE (BtuH)*

Outdoor Ambient Temperature (DB)	Indoor Entering Air Temperatures							
	65°F DB		68°F DB		73°F DB		79°F DB	
	55°F WB		57°F WB		61°F WB		64°F WB	
	TC	SHC	TC	SHC	TC	SHC	TC	SHC
5°F	9,980	7,820	10,900	8,550	11,540	9,050	12,370	9,720
14°F	10,480	8,220	11,480	9,010	12,130	9,510	12,950	10,160
23°F	11,710	9,180	12,580	9,870	13,460	10,560	14,330	11,240
32°F	12,330	9,680	13,250	10,400	14,180	11,120	15,090	11,830
41°F	12,950	10,170	13,920	10,920	14,890	11,680	15,800	12,430
50°F	13,580	10,660	14,590	11,450	15,610	12,240	16,500	13,030
59°F	14,200	11,130	15,260	11,970	16,320	12,800	17,380	13,630
68°F	16,200	12,710	17,280	13,550	18,360	14,400	19,080	14,960
77°F	15,990	12,540	17,080	13,390	18,160	14,250	18,900	14,820
86°F	15,160	11,890	16,240	12,730	17,320	13,580	18,180	14,260
95°F	14,300	11,210	15,370	12,050	16,440	12,890	17,510	13,740
104°F	13,550	10,620	14,620	11,470	15,690	12,310	16,760	13,150
113°F	12,800	10,040	13,870	10,880	14,940	11,720	16,010	12,560
122°F	12,420	9,740	13,500	10,590	14,400	11,290	15,480	12,140

HEATING PERFORMANCE (BtuH)*

Outdoor Ambient Temperature (DB)	Indoor Entering Air Temperatures							
	65°F DB		68°F DB		73°F DB		79°F DB	
	55°F WB		57°F WB		61°F WB		64°F WB	
	TC	SHC	TC	SHC	TC	SHC	TC	SHC
-22°F	15,990	15,990	15,510	15,510	15,350	15,350	15,200	15,200
-4°F	17,790	17,790	17,250	17,250	17,080	17,080	16,910	16,910
0°F	19,190	19,190	18,610	18,610	18,420	18,420	18,240	18,240
6°F	19,990	19,990	19,390	19,390	19,190	19,190	19,000	19,000
10°F	19,990	19,990	19,390	19,390	19,190	19,190	19,000	19,000
16°F	19,990	19,990	19,390	19,390	19,190	19,190	19,000	19,000
19°F	19,990	19,990	19,390	19,390	19,190	19,190	19,000	19,000
24°F	19,990	19,990	19,390	19,390	19,190	19,190	19,000	19,000
32°F	19,990	19,990	19,390	19,390	19,190	19,190	19,000	19,000
41°F	19,990	19,990	19,390	19,390	19,190	19,190	19,000	19,000
43°F	19,990	19,990	19,390	19,390	19,190	19,190	19,000	19,000
47°F	19,990	19,990	19,390	19,390	19,190	19,190	19,000	19,000
53°F	20,190	20,190	19,580	19,580	19,380	19,380	19,190	19,190
59°F	20,650	20,650	20,030	20,030	19,830	19,830	19,630	19,630
64°F	21,090	21,090	20,450	20,450	20,250	20,250	20,050	20,050
70°F	21,490	21,490	20,840	20,840	20,630	20,630	20,430	20,430
75°F	21,790	21,790	21,130	21,130	20,920	20,920	20,710	20,710
78°F	21,990	21,990	21,330	21,330	21,110	21,110	20,900	20,900

* Maximum system capacity

TC- Total Capacity (BtuH)
 SHC- Sensible Capacity (BtuH)

MINIMUM SPACING REQUIREMENTS

Units: inch (mm)

INDOOR

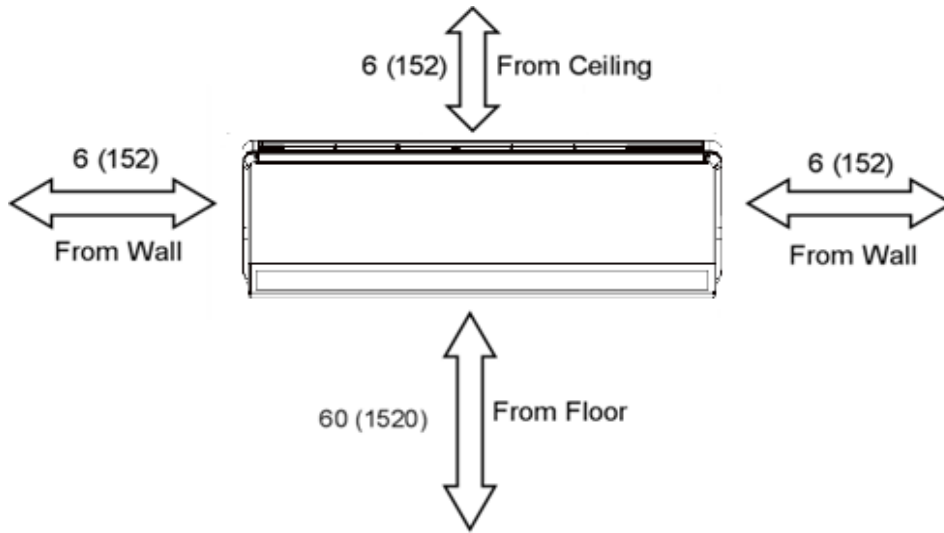

Units: inch (mm)

OUTDOOR

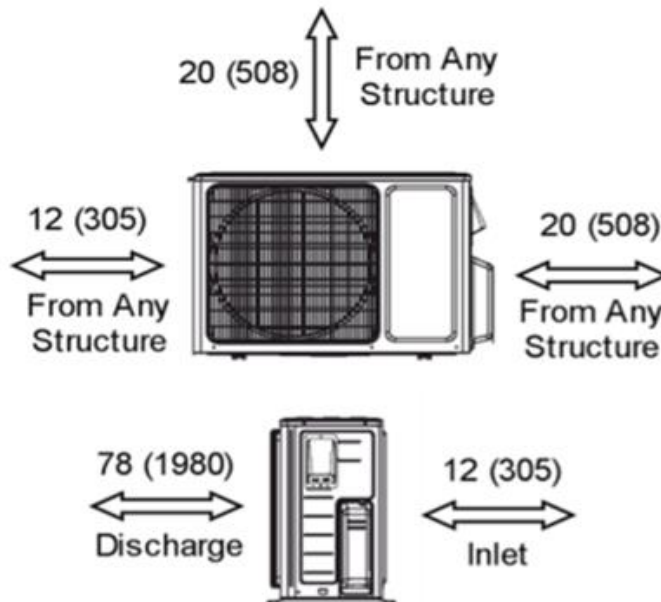

DIMENSIONAL SPECIFICATIONS

CROWN18HP230V1B

INDOOR UNIT DIMENSIONS

Units: inch

Model No: CROWN18HP230V1BH

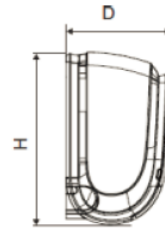
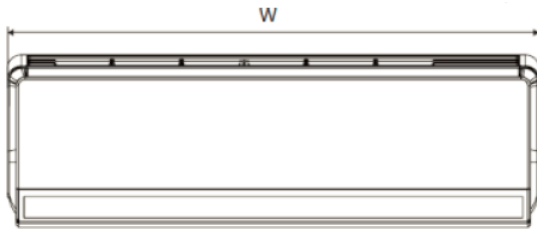

Dimensions	
W	37.8
H	12.6
D	8.1

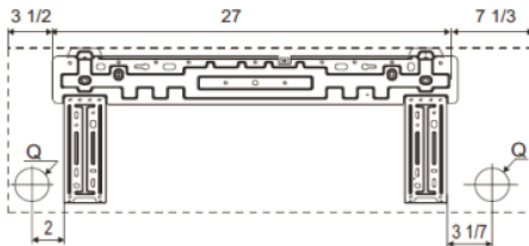

Weight (Net/Shipping) 30.8/37.5 LBS

Liquid Line Valve	1/4-in OD Flared
Gas Line Valve	5/8-in OD Flared
Drain Connector	5/8-in OD

OUTDOOR UNIT DIMENSIONS

Units: inch

Model No: CROWN18HP230V1BO

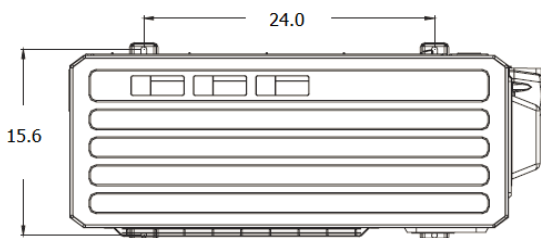
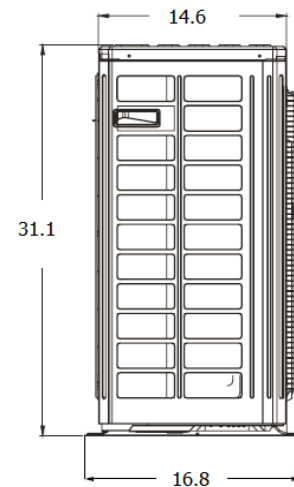
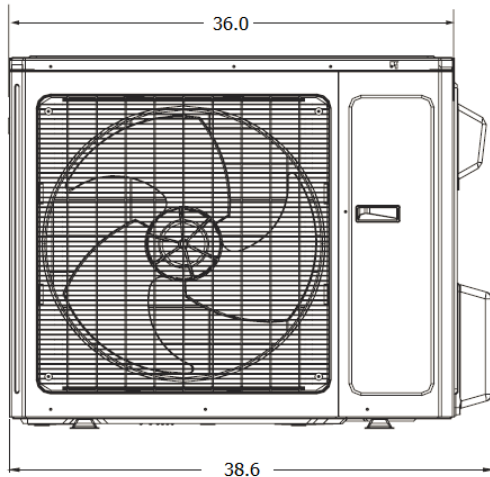

Liquid Line Valve	1/4-in OD Flared
Gas Line Valve	5/8-in OD Flared

Weight (Net/Shipping) 141.1/152.1 LBS

Notes:

1. Recommended Interconnecting Cable Type 14 AWG 4 Stranded Copper Conductors THHN 600V Wire
2. Power wiring cable size must comply with applicable national and local codes.
3. Test conditions are based on AHRI 210/240.

Specifications are subject to change without notice. Manufacturer reserves the right to discontinue or modify specifications or designs without notice or without incurring obligations. All rights reserved.