

PARTS MANUAL

Indoor Unit Models:

FLEXX24HP230V1BH

FLEXX36HP230V1BH

FLEXX48HP230V1BH

FLEXX60HP230V1BH

Outdoor Unit Models:

FLEXX36AC230V1AO

FLEXX60AC230V1AO

FLEXX36HP230V1AO

FLEXX60HP230V1AO

FLEXX36AC230V1AO

EXPLODED VIEW

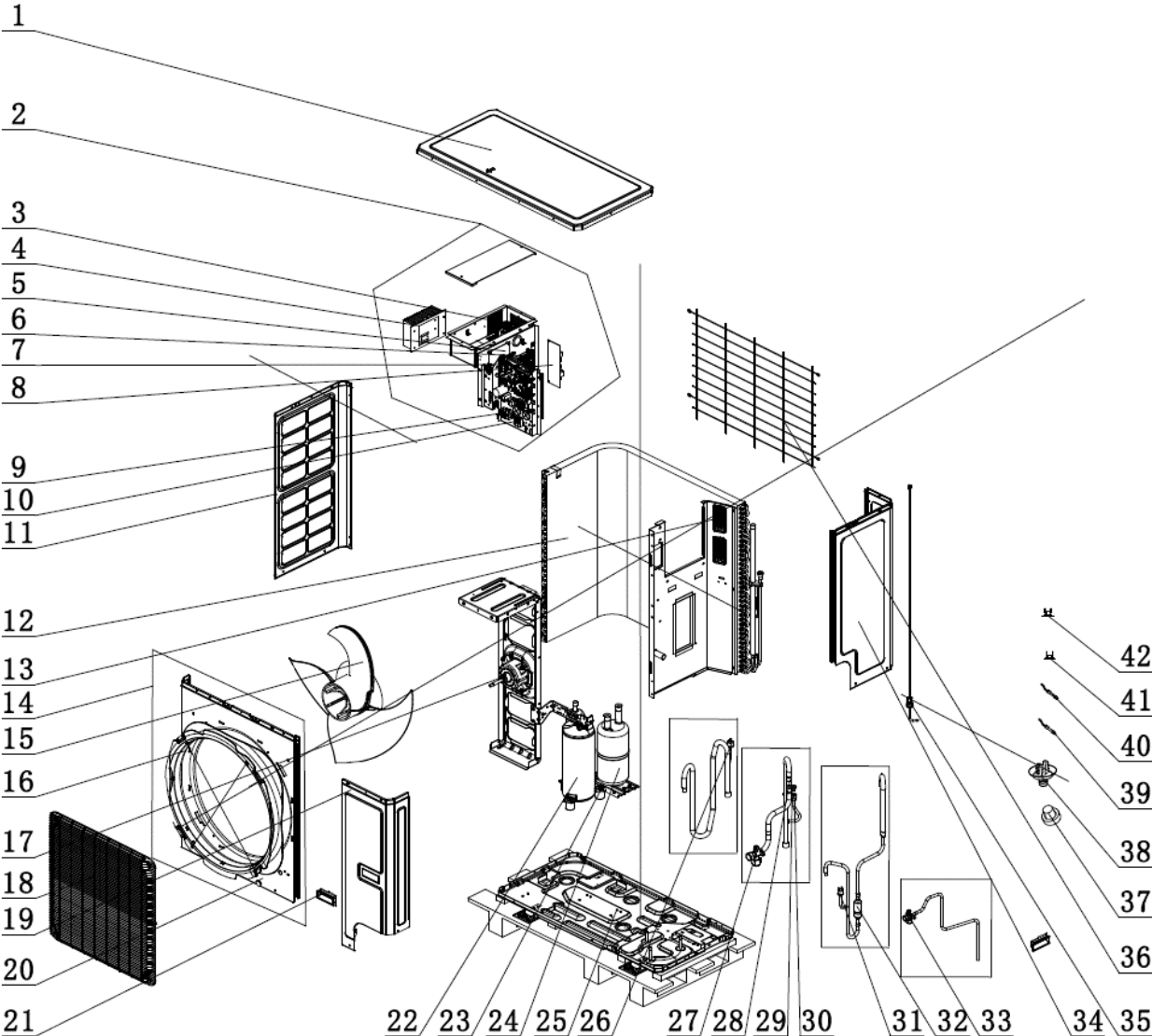

FLEXX36AC230V1AO

NO.	Part Description	Qty	Part Code
1	Coping (Cover)	1	01264100052P03
2	Electric Box Assy	1	100002070111
3	PFC Inductance	1	43120011
4	Radiator	1	430034000048
5	Power Switch	1	300012060016
6	Driver Board	1	300078060152
7	Main Board	1	300027061349
8	Filter Board	1	300020060028
9	Terminal Board (3 Post Power)	1	422000000015
10	Terminal Board (3 Post Communication)	1	4201025903
11	Left Side Plate	1	012055000007P03
12	Condenser Assy	1	000100060396
13	Coil Filter Strainer Sub-Assy	2	111001000086
14	Cabinet Assy	1	000006060040
15	Axial Flow Fan	1	1043410000801
16	Diversion Circle	1	10474100003
17	DC Fan Motor	1	150104060013
18	Front Grill	1	0157280000301
19	Front Side Plate	1	012050000007P03
20	Cabinet	1	012022000003P03
21	Handle	2	2690410001603
22	Gas-liquid Separator	1	07423902
23	Compressor and Fittings	1	009001060218ST
24	Compressor Gasket	3	009012000004
25	Chassis Assy	1	209058060266
26	Lo-Pressure Protect Switch 0.05/0.15MPa	1	46020007
27	Cut off Valve -3/4	1	07330000001
28	Filter Strainer (Gas Line)	1	07224803
29	Fusible Plug	1	035222000004
30	Joint	1	06652200001
31	Hi-Pressure Protect Switch 4.6/3.8MPa	1	4602000603
32	Silencer	1	07245012
33	Cut off Valve -3/8	1	071302391
34	Rear Side Plate	1	012076000021P03
35	Lo-Pressure Sensor	1	430044000016
36	Rear Grill	1	0157410001402

FLEXX36AC230V1AO

37	Drainage hole Cap	3	76715005
38	Drainage Joint (Drain Hose Adapter)	0	none
39	Temperature Sensor (Low Temp Cooling) AP3-T_LAC	1	3900007201
40	Temperature Sensor(Discharge, Coil, & Ambient)	1	39008000049G
41	Compressor Overload Protector(External)	1	00183031
42	Compressor Overload Protector(External) KSD115	1	00183031
	Compressor Overload Protector(External)	1	00183031

ASSEMBLIES

2	Electric Box Assy	1	100002070111
3	PFC Inductance	1	43120011
4	Radiator	1	430034000048
5	Power Switch	1	300012060016
6	Driver Board	1	300078060152
7	Main Board	1	300027061349
8	Filter Board	1	300020060028
9	Terminal Board (3 Post Power)	1	422000000015
10	Terminal Board (3 Post Communication)	1	4201025903

FLEXX60AC230V1AO

EXPLODED VIEW

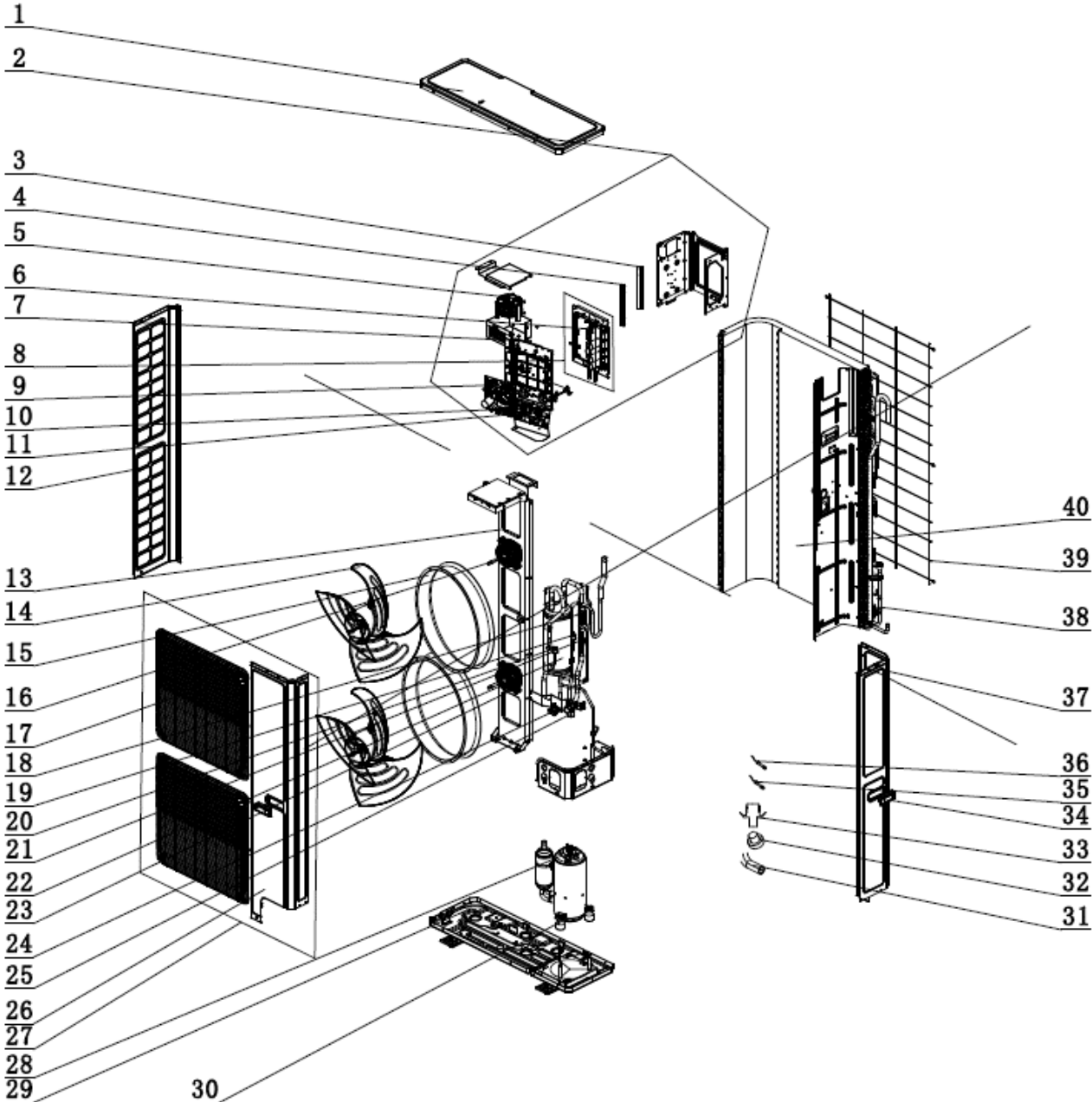

FLEXX60AC230V1AO

NO.	Part Description	Qty	Part Code
1	Coping (Top Cover)	1	01264100047P02
2	Electric Box Assy	1	100002070110
3	Radiator 2	1	4901800009801
4	Radiator 1	1	49018000097
5	PFC Inductance	1	43128000015
6	Driver Board	1	300078060060
7	Filter Board	1	300020060007
8	Driver Board Electric Box Assy	1	100002066513
9	Main Board	1	300027061349
10	Terminal Board (3 Post Power)	1	42200006001201
11	Terminal Board (3 Post Communication)	1	4201025903
12	Left Side Plate	1	01314100084P02
13	Motor Support Sub-Assy	1	01804100391
14	Axial Flow Fan	2	10434100006
15	Diversion Circle	2	1047410000301
16	DC Fan Motor (Upper-Green Plug)	1	15010406001302
17	Front Grill	2	0157280000301
18	Filter Strainer (Gas-liquid Separator)	1	07210037
19	Hi-Pressure Protect Switch 4.6/3.8MPa	1	4602000603
20	Lo-Pressure Protect Switch 0.05/0.15MPa	1	46020007
21	Lo-Pressure Sensor	1	430044000016
22	Gas-liquid Separator	1	07225016
23	DC Fan Motor (Lower-White Plug)	1	150104060013
24	Cut off Valve -3/8	1	07330000002
25	Cut off Valve -3/4	1	07330000001
26	Front Side Plate	1	01314100082P02
27	Cabinet Assy	1	000006060084
28	Compressor and Fittings	1	009001060377ST
29	Chassis Sub-assy	1	000191060091
30	Compressor Gasket	3	009012000013
31	Drainage Joint (Drain Hose Adapter)	1	26113009
32	Drainage hole Cap	3	76715005
33	Fusible Plug	1	035222000004
34	Handle	2	2690410001603
35	Temperature Sensor (Low Temp Cooling) AP3-T_LAC	1	3900007201

FLEXX60AC230V1AO

36	Temperature Sensor(Discharge, Coil, & Ambient)	1	3900028025G
37	Rear Side Plate	1	01314100083P02
38	Filter Strainer (Coil Distributor)	1	07212403
39	Rear Grill	1	0157410001101
40	Condenser Assy	1	011002060836

ASSEMBLIES

2	Electric Box Assy	1	100002070110
3	Radiator 2	1	4901800009801
4	Radiator 1	1	49018000097
5	PFC Inductance	1	43128000015
6	Driver Board	1	300078060060
7	Filter Board	1	300020060007
8	Driver Board Electric Box Assy	1	100002066513
9	Main Board	1	300027061349
10	Terminal Board (3 Post Power)	1	42200006001201
11	Terminal Board (3 Post Communication)	1	4201025903

FLEXX36HP230V1AO

EXPLODED VIEW

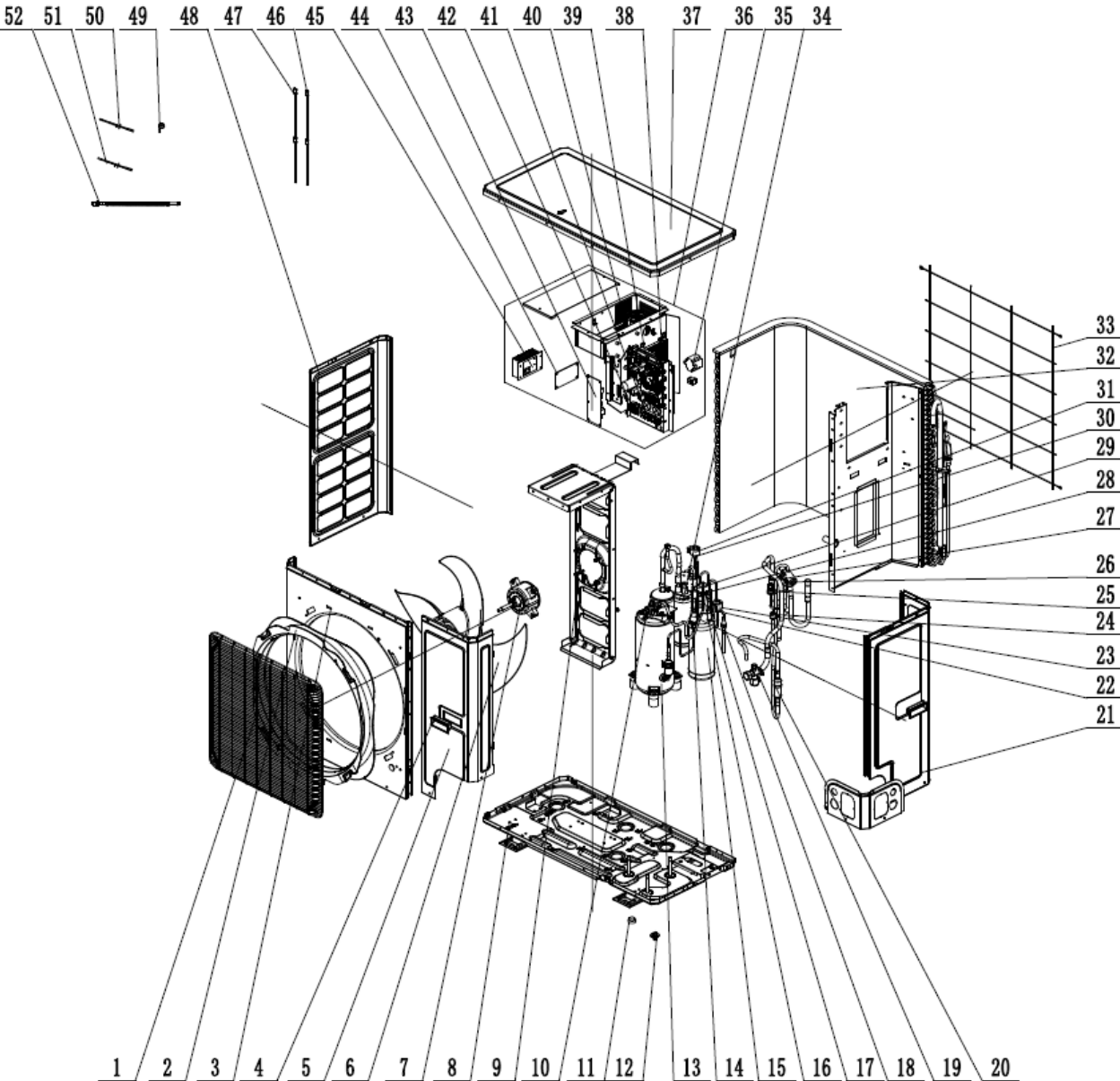

FLEXX36HP230V1AO

NO.	Part Description	Qty	Part Code
1	Front Grill	1	0157280000301
2	Diversion Circle	1	10474100003
3	Cabinet	1	012022000003P03
4	Handle	2	2690410001603
5	Front Side Plate	1	012050000007P03
6	Axial Flow Fan	1	1043410000801
7	DC Fan Motor	1	150104060013
8	Chassis Sub-Assy	1	01700006008907P
9	Motor Support Sub-Assy	1	01701206003901
10	Cut off Valve -3/8	1	071302391
11	Drainage hole Cap	3	76715005
12	Drainage Joint (Drain Hose Adapter)	1	26113009
13	Compressor and Fittings	1	009001060125
14	Filter Strainer (Liquid Line Cut-Off Valve)	2	0721004501
15	Accumulator	1	035029000003
Not Shown	Electromagnetic Valve Sub-assy		030025060094
16	Electromagnetic Valve	1	43003091
17	Magnet Coil (Electromagnetic Valve)	1	4304000467
18	Filter Strainer (Compressor Suction)	1	0721304401
19	Cut off Valve -3/4	1	07330000001
20	Silencer	1	07245012
21	Rear Side Plate	1	012076000021P03
22	Electronic Expansion Valve	1	43005017
23	Electric Expand Valve Fitting	1	4300034404
24	Hi-Pressure Protect Switch 4.6/3.8MPa	1	4602000603
25	Hi-Pressure Sensor	1	43004400001501
26	4-way Valve	1	4300008201
27	Filter Strainer (Accumulator Suction)	1	07224803
28	Filter Strainer(Electromagnetic Valve)	2	07216221
29	One Way Valve	1	07133618
30	Electronic Expansion Valve	1	43005017
31	Electric Expansion Valve Coil	1	43000344
32	Condenser Assy	1	01100206019001
33	Rear Grill	1	0157410001402
34	Gas-liquid Separator	1	07223048
35	Inductance	1	43128000014

FLEXX36HP230V1AO

36	Electric Box Assy	1	100002065509
37	Coping	1	01264100052P03
38	Main Board2	1	300027060524
39	Main Board	1	300027060636
40	PFC Inductance	1	43120011
41	Terminal Board (6 Post)	1	4201025502
42	Terminal Board (3 Post)	1	422000000015
43	Filter Board	1	300020060028
44	Power Switch	1	300012060016
45	Radiator	1	430034000048
46	Electrical Heater (Chassis)	1	7651000413
47	Electrical Heater(Compressor)	1	7651521238
48	Left Side Plate	1	012055000007P03
49	4 Way Valve Coil	1	4300040094
50	Temperature Sensor (4-Way Valve)	1	3900007201
51	Temperature Sensor(Discharge, Coil, & Ambient)	1	39008000049G
52	Corrugated Pipe (Optional)	0	none

ASSEMBLIES

Not Shown	Electromagnetic Valve Sub-assy		030025060094
22	Electromagnetic Valve	1	43003091
23	Magnet Coil (electromagnetic valve)	1	4304000467
Not Shown	4-way Valve Assy	1	030152060295
26	4-way Valve	1	4300008201
49	4 Way Valve Coil	1	4300040094

FLEXX60HP230V1AO

EXPLODED VIEW

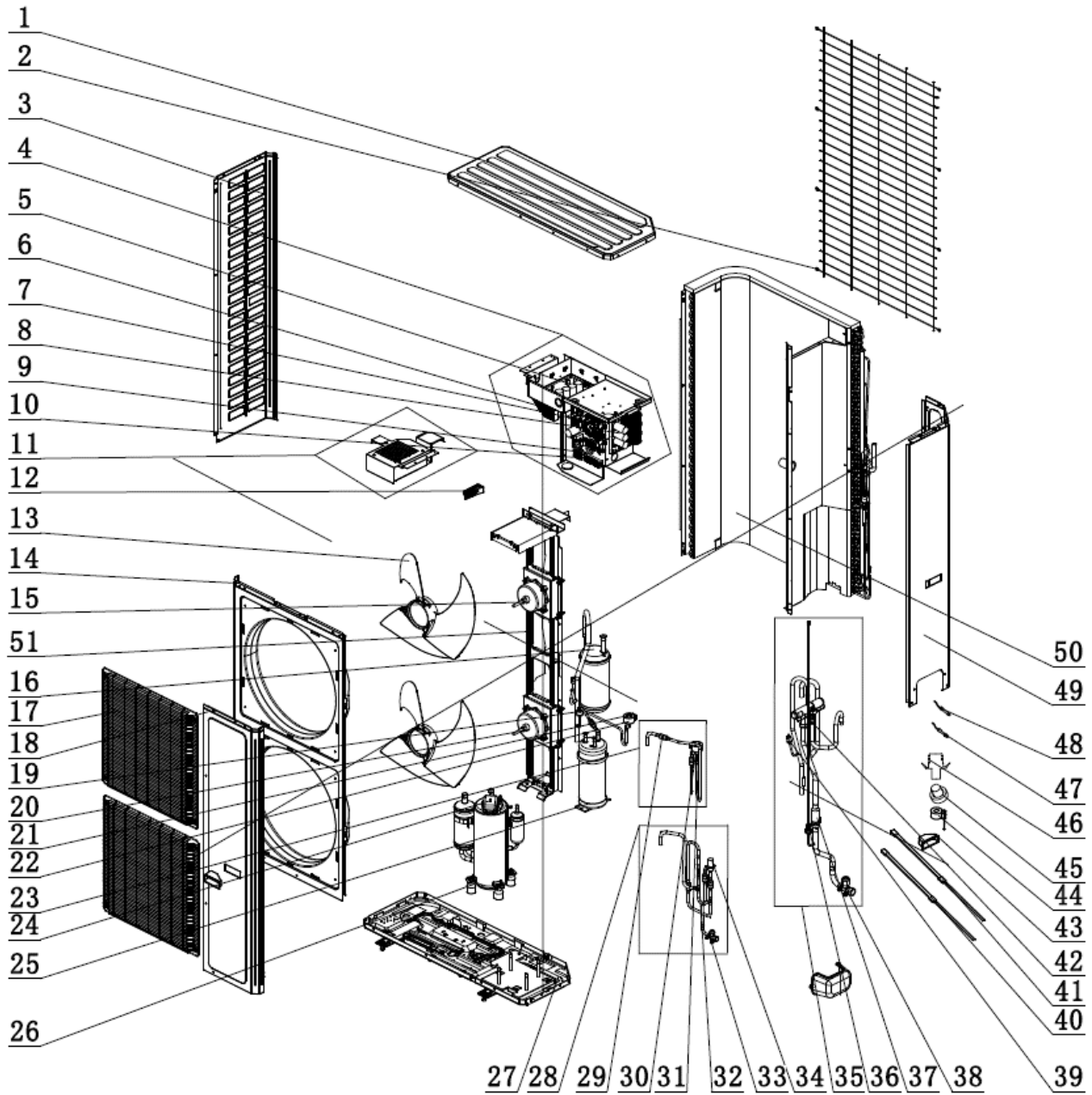

FLEXX60HP230V1AO

NO.	Part Description	Qty	Part Code
1	Coping (Top Cover)	1	01265356P03
2	Rear Grill	1	0157520501
3	Left Side Plate	1	01315366P02
4	Electric Box Assy	1	100002072979
5	Driver Board	1	300078060066
6	Radiator	1	430034000032
7	Main Board	1	300027060636
8	Filter board	1	300020060032
9	Terminal Board (3 Post Power)	1	422000000015
10	Terminal Board (6 Post)	1	4201025504
11	Inductance Box Assy	1	000221060023
12	Handle	1	2623305301
13	Axial Flow Fan	2	10335008
14	Cabinet	1	01515204P02
15	DC Fan Motor (Upper)	1	1570280000410
16	Gas-liquid Separator Sub-Assy	1	0722501801
17	Front Grill	2	01600400000601
18	Front Side Plate	1	01315364P02
19	Lo-Pressure Protect Switch 0.05/0.15MPa	1	46020007
20	DC Fan Motor (Lower)	1	1570280000403
21	Electromagnetic Valve	1	43003091
22	Electric Expand Valve Fitting	1	4300034501
23	Electric Expansion Valve Sub-Assy	1	030026060648
24	Compressor and Fittings	1	009001000266
25	Accumulator	1	07424100031
26	Foot (Compressor Isolator)	2	01215004
27	Chassis Sub-Assy	1	017080060140P
28	Cut off Valve Sub-Assy	1	030057060280
29	Filter Strainer (Electromagnetic Valve)	6	07216221
30	Magnet Coil (electromagnetic valve)	1	4304000488
31	Electric Expand Valve Fitting	1	4300034502
32	One Way Valve	1	07133618
33	Cut off Valve -3/4	1	07130212
34	Electronic Expansion Valve	2	072009060004
35	4-Way Valve Assy	1	030152060548
36	Pressure Sensor	1	43004400001503

FLEXX60HP230V1AO

37	Filter Strainer (4-Way Valve)	1	07210037
38	Cut off Valve -3/8	1	07130209
39	Hi-Pressure Protect Switch 4.6/3.8MPa	1	4602000603
40	Electrical Heater (Chassis)	1	7651000417
41	Electrical Heater (Compressor)	3	7651521246
42	4-way Valve	1	43000338
43	Handle	2	2623525309
44	4 Way Valve Coil	1	4300040094
45	Drainage hole Cap	3	06813401
46	Drainage Joint (Drain Hose Adapter)	1	06123401
47	Temperature Sensor(Discharge, Coil, & Ambient)	1	3900028025G
48	Temperature Sensor (4-Way Valve)	1	3900007201
49	Rear Side Plate Sub-Assy	1	017051060121P
50	Condenser Assy	1	000100060341
51	Motor Support Sub-Assy	1	01805200246

ASSEMBLIES

4	Electric Box Assy	1	100002072979
5	Driver Board	1	300078060066
6	Radiator	1	430034000032
7	Main Board	1	300027060636
8	Filter board	1	300020060032
9	Terminal Board (3 Post Power)	1	422000000015
10	Terminal Board (6 Post)	1	4201025504
23	Electric Expansion Valve Sub-Assy	1	030026060648
29	Filter Strainer (Electomagnetic Valve)	6	07216221
30	Magnet Coil (electromagnetic valve)	1	4304000488
31	Electric Expand ValveCoil	1	4300034502
28	Cut off Valve Sub-Assy	1	030057060280
32	One Way Valve	1	07133618
33	Cut off Valve -3/4	1	07130212
34	Electronic Expansion Valve	2	072009060004
35	4-Way Valve Assy	1	030152060548

FLEXX60HP230V1AO

36	Pressure Sensor	1	43004400001503
37	Filter Strainer (4-Way Valve)	1	07210037
38	Cut off Valve -3/8	1	07130209
39	Hi-Pressure Protect Switch 4.6/3.8MPa	1	4602000603
42	4-way Valve	1	43000338

FLEXX24HP230V1BH
FLEXX36HP230V1BH
EXPLODED VIEW

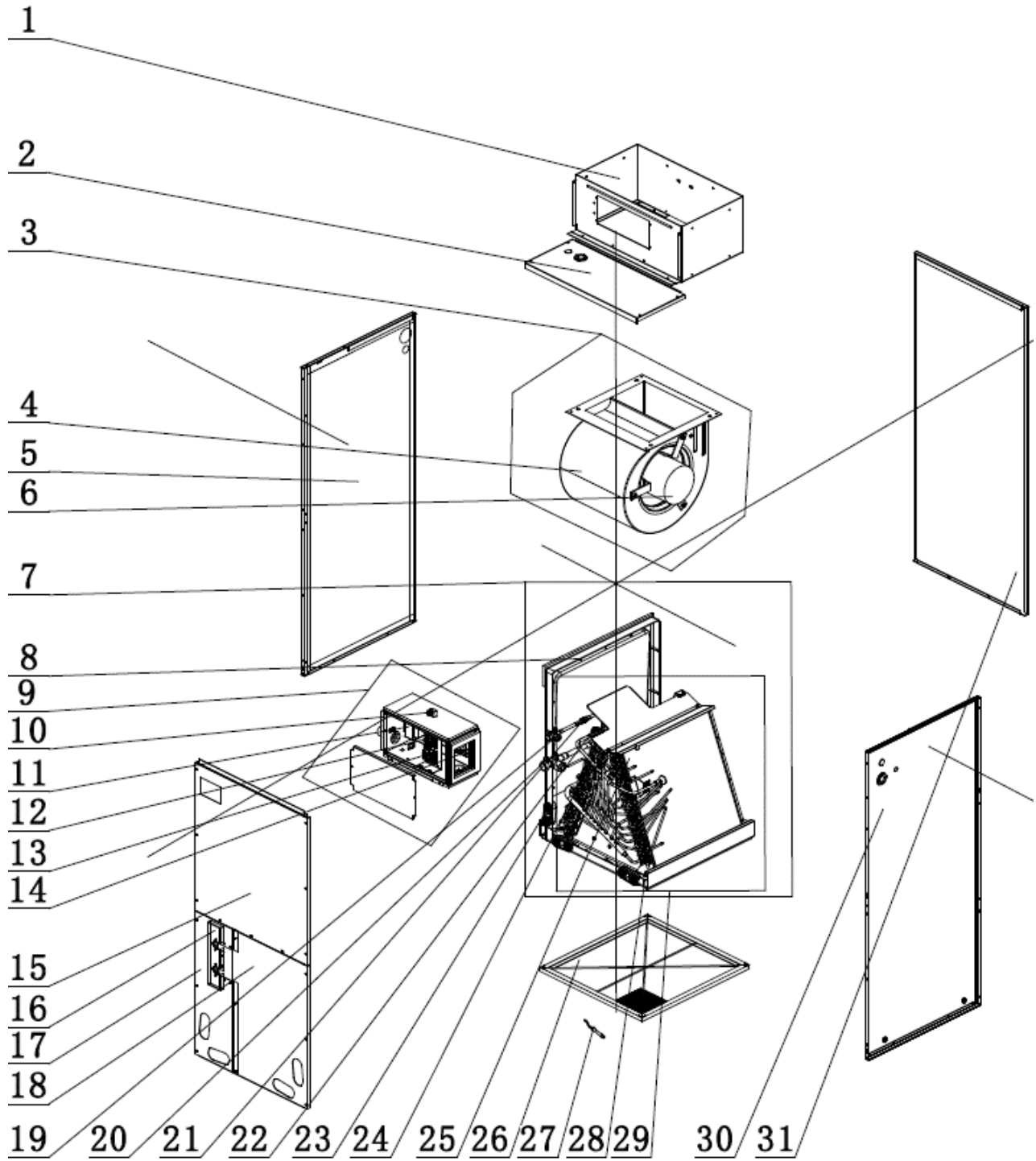

FLEXX24HP230V1BH
FLEXX36HP230V1BH

NO.	Part Description	Qty	Part Code
1	Side Plate	1	012010060972
2	Top Cover Sub-Assy	1	000051060106
3	Centrifugal fan assy	1	000052060415
4	Centrifugal Fan Housing	1	1570220201
5	Brushless DC Motor	1	15010400001401
6	Left Side Plate Sub-Assy	1	01312200015
7	Water Tray Assy	1	000069060335
8	Water Tray	1	2690220501
9	Electric Box Assy	1	100002070100
10	Terminal Board (1 Post)	1	42011147
11	Transformer	1	43110286
12	Terminal Board (6 Post)	1	4201025503
13	Terminal Board (2 Post)	1	42000100000102
14	Main Board	1	300002061591
15	Top Cover Board Sub-assy	1	01262200019
16	Bottom Cover Plate Assy	1	000133060017
17	Bottom Cover Plate Assy	1	000133060018
18	Bottom Cover Plate 2	1	01262200017
19	Cut off Valve -3/8	1	071302391
20	Thermal Expansion Valve	1	071017060022
21	Cut off Valve -3/4	1	070001000009
22	Filter Strainer (Liquid Line)	2	0721200102
23	Choke Plug	8	76718209
24	Evaporator assembly (left)	1	010001060291
25	Evaporator assembly (right)	1	010001060292
26	Air Filter Sub-Assy	1	111001060160
27	Temperature Sensor	1	390001923
28	Evaporator Assy Parts	1	011001061481
29	Water Tray	1	2690220401
30	Right Side Plate	1	012056060205P
31	Rear Side Plate Sub-Assy	1	01312200019

ASSEMBLIES

3	Centrifugal fan assy	1	000052060415
4	Centrifugal Fan Housing	1	1570220201
5	Brushless DC Motor	1	15010400001401

FLEXX48HP230V1BH
FLEXX60HP230V1BH
EXPLODED VIEW

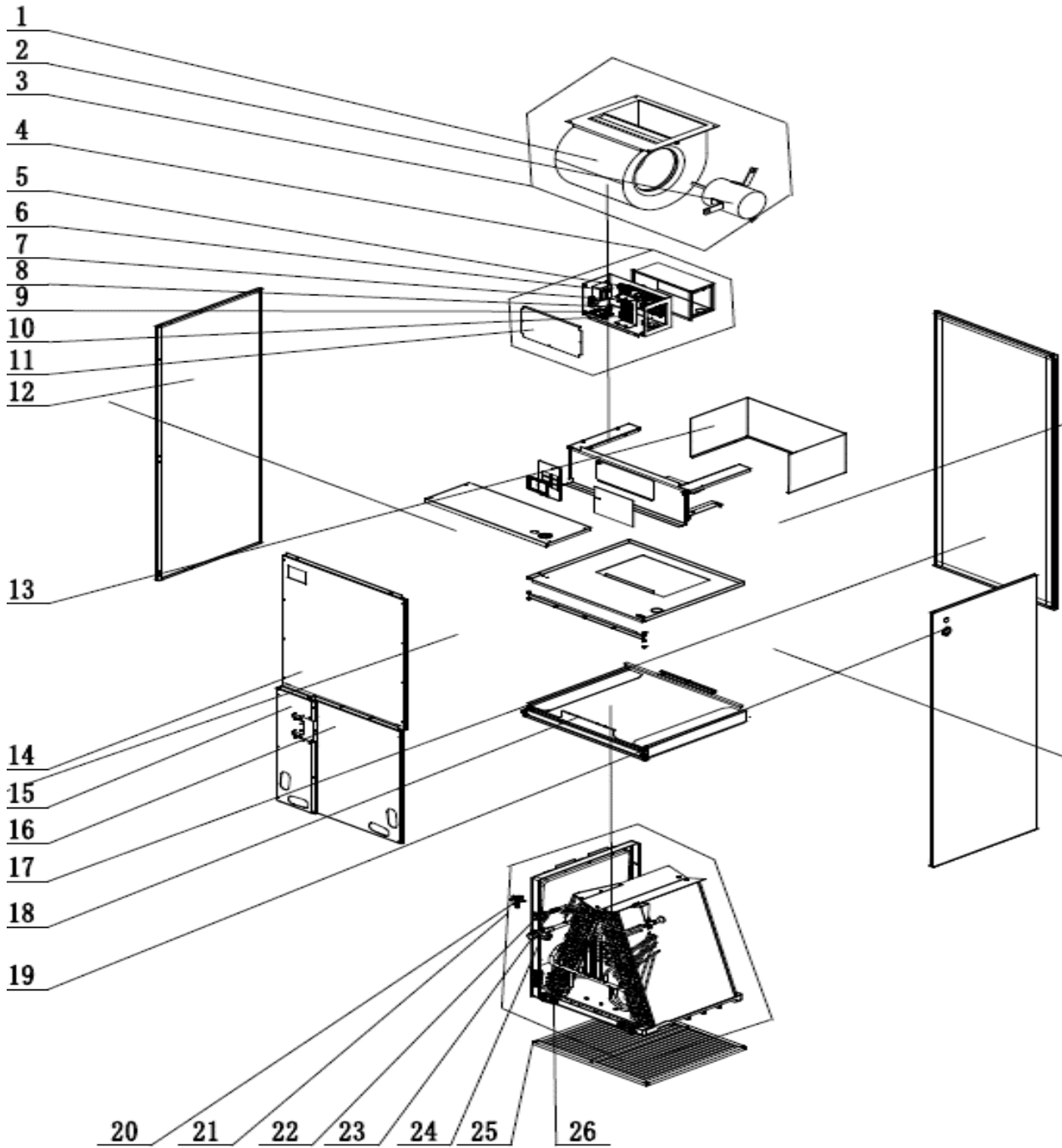

FLEXX48HP230V1BH FLEXX60HP230V1BH

NO.	Part Description	Qty	Part Code
1	Centrifugal Fan Housing	1	1570220301
2	DC Fan Motor	1	15010400001301
3	Centrifugal Fan Assy	1	000052060413
4	Electric Box Assy	1	100002070100
5	Terminal Board (1 Post)	1	42011147
6	Transformer	1	43110286
7	Main Board	1	300002061591
8	Terminal Board (6 Post)	1	4201025503
9	Pinboard	0	none
10	Terminal Board (2 Post)	1	42000100000102
11	Electric Box Cover	1	012020060452
12	Left Side Plate Sub-Assy	1	017037060170
13	Air Scroll	1	012277060111
14	Top Cover Board Sub-assy	1	017011060115
15	Bottom Cover Plate	1	017010060042P
16	Bottom Cover Plate 2	1	01262200026
17	Rear Side Plate Sub-Assy	1	017051060118
18	Water Tray Assy	1	000069060357
19	Right Side Plate Sub-Assy	1	000130060099
20	Thermal Expansion Valve	1	071017060028
21	Evaporator Assy	1	011001061545
22	Cut off Valve -3/8	1	071302391
23	Filter Strainer (Liquid Line)	3	0721200102
24	Cut off Valve -3/4	1	070001000009
25	Filter Sub-Assy	1	111001060188
26	Choke Plug	8	76718209

ASSEMBLIES

1	Centrifugal Fan Housing	1	1570220301
2	DC Fan Motor	1	15010400001301
3	Centrifugal Fan Assy	1	000052060413
4	Electric Box Assy	1	100002070100
5	Terminal Board	1	42011147
6	Transformer	1	43110286
7	Main Board	1	300002061591

FLEXX48HP230V1BH

FLEXX60HP230V1BH

8	Terminal Board	1	4201025503
9	Pinboard	0	none
10	Terminal Board	1	42000100000102
11	Electric Box Cover	1	012020060452
21	Evaporator Assy	1	011001061545
14	Top Cover Board Sub-assy	1	017011060115
22	Cut off Valve	1	071302391
23	Strainer	3	0721200102
24	Cut off Valve	1	070001000009
26	Choke Plug	8	76718209



U.S. CONTACT INFORMATION TRADEWINDS, LLC

E-mail: info@twclimate.com

Contractor Support: 888-850-7928 | Mon-Fri 8 AM - 5 PM EDT

www.greecomfort.com/system-documentation/

GREE ELECTRIC APPLIANCES, INC. OF ZHUHAI

Add: West Jinji RD, Qianshan, Zhuhai, Guangdong, China, 519070

Tel: (+86-756) 8522218

Fax: (+86-756) 8669426

E-mail: gree@gree.com.cn

www.gree.com