

- EXTRUDED ALUMINUM CONSTRUCTION
- HINGES LOCATED AT BOTTOM ON WIDTH DIMENSION
- REMOVABLE FACE
- OPTIONAL FACE MOUNTING HOLES WITH SCREWS
- BARS ON 3/4 INCH CENTERS
- FILTER FRAME MAY BE SCREW FASTENED TO DUCT
- USES NOMINAL 1 INCH DISPOSABLE FILTERS
- FILTER SIZE EQUALS LISTED SIZE MINUS 1/4 INCH
- MINIMUM SIZE: 6 X 4
- MAXIMUM SIZE: 48 X 48 ONE PIECE CONSTRUCTION
- AVAILABLE IN 1 INCH INCREMENTS
- SATIN ANODIZED (SA) OR WHITE (W) ENAMEL FINISH

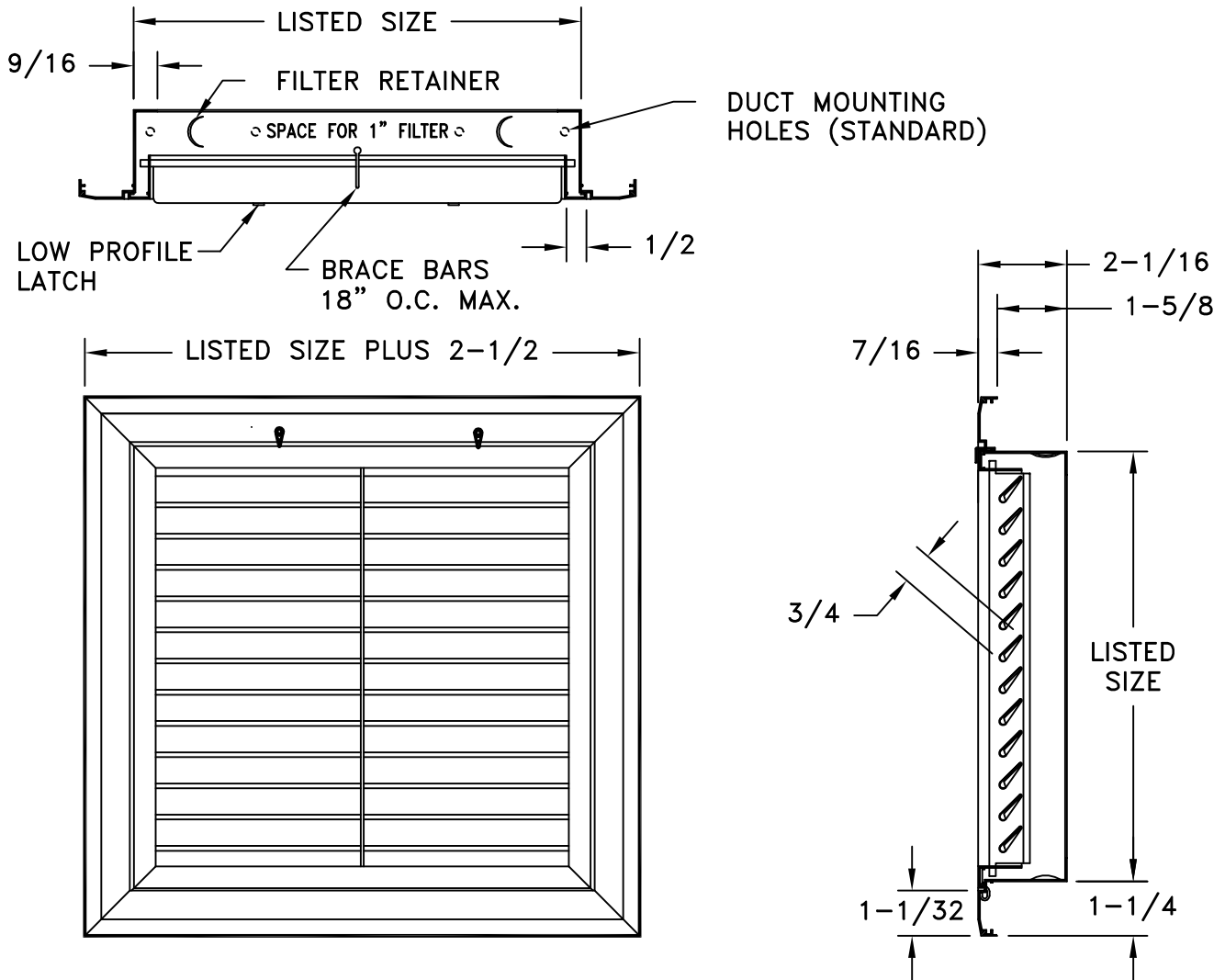

JOB NAME: _____
 LOCATION: _____
 ARCHITECT: _____
 ENGINEER: _____
 CONTRACTOR: _____

SUBMITTED BY: _____

DATE: 06/18/2-13 | SD-9126

RHF45
 Extruded Aluminum
 Return Air Filter Grille