

KOOLAIRE Ice Machines

Technician's Handbook

This manual is updated as new information and models are released. Visit our website for the latest manual.
www.kool-aire.com



Safety Notices

As you work on Manitowoc equipment, be sure to pay close attention to the safety notices in this handbook. Disregarding the notices may lead to serious injury and/or damage to the equipment.

Throughout this handbook, you will see the following types of safety notices:

Warning

Text in a Warning box alerts you to a potential personal injury situation. Be sure to read the Warning statement before proceeding, and work carefully.

Caution

Text in a Caution box alerts you to a situation in which you could damage the equipment. Be sure to read the Caution statement before proceeding, and work carefully.

Procedural Notices

As you work on Manitowoc equipment, be sure to read the procedural notices in this handbook. These notices supply helpful information which may assist you as you work.

Throughout this handbook, you will see the following types of procedural notices:

Important

Text in an Important box provides you with information that may help you perform a procedure more efficiently. Disregarding this information will not cause damage or injury, but it may slow you down as you work.

NOTE: Text set off as a Note provides you with simple, but useful, extra information about the procedure you are performing.

Read These Before Proceeding:

Caution

Proper installation, care and maintenance are essential for maximum performance and trouble-free operation of your Manitowoc equipment. If you encounter problems not covered by this manual, do not proceed, contact Manitowoc Foodservice. We will be happy to provide assistance.

Caution

Proper installation, care and maintenance are essential for maximum performance and trouble-free operation of your equipment. Visit our website www.manitowocfsg.com for manual updates, translations, or contact information for service agents in your area.

Important

Routine adjustments and maintenance procedures outlined in this handbook are not covered by the warranty.

Warning

Read this manual thoroughly before operating, installing or performing maintenance on the equipment. Failure to follow instructions in this manual can cause property damage, injury or death.

⚠ Warning

Do not use electrical appliances or accessories other than those supplied by Manitowoc for your ice machine model.

⚠ Warning

Two or more people or a lifting device are required to lift this appliance.

⚠ Warning

This equipment contains high voltage electricity and refrigerant charge. Installation and repairs are to be performed by properly trained technicians aware of the dangers of dealing with high voltage electricity and refrigerant under pressure. The technician must also be certified in proper refrigerant handling and servicing procedures. All lockout and tag out procedures must be followed when working on this equipment.

⚠ Warning

Do not damage the refrigeration circuit when installing, maintaining or servicing the unit.

⚠ Warning

Do not operate equipment that has been misused, abused, neglected, damaged, or altered/modified from that of original manufactured specifications. This appliance is not intended for use by persons (including children) with reduced physical, sensory or mental capabilities, or lack of experience and knowledge, unless they have been given supervision concerning use of the appliance by a person responsible for their safety. Do not allow children to play with this appliance.

⚠ Warning

All covers and access panels must be in place and properly secured, before operating this equipment.

⚠ Warning

Do not obstruct machine vents or openings.

⚠ Warning

Do not store gasoline or other flammable vapors or liquids in the vicinity of this or any other appliance.

⚠ Warning

Do not clean with water jet.

⚠ Warning

It is the responsibility of the equipment owner to perform a Personal Protective Equipment Hazard Assessment to ensure adequate protection during maintenance procedures.

⚠ Warning

Two or more people are required to move this equipment to prevent tipping.

Warning

When using electric appliances, basic precautions must always be followed, including the following:

- a. Read all the instructions before using the appliance.
- b. To reduce the risk of injury, close supervision is necessary when an appliance is used near children.
- c. Do not contact moving parts.
- d. Only use attachments recommended or sold by the manufacturer.
- e. Do not use outdoors.
- f. For a cord-connected appliance, the following must be included:
 - Do not unplug by pulling on cord. To unplug, grasp the plug, not the cord.
 - Unplug from outlet when not in use and before servicing or cleaning.
 - Do not operate any appliance with a damaged cord or plug, or after the appliance malfunctions or is dropped or damaged in any manner. Contact the nearest authorized service facility for examination, repair, or electrical or mechanical adjustment.
- g. Follow applicable lock out tag out procedures before working on equipment.
- h. Connect to a properly grounded outlet only.

We reserve the right to make product improvements at any time. Specifications and design are subject to change without notice.

THIS PAGE INTENTIONALLY LEFT BLANK

Table of Contents

General Information

Model Numbers	15
Ice Machine Warranty Information	15
How to Read a Model Number	16

Installation

Location of Ice Machine	17
Ice Machine Clearance Requirements	18
Ice Machine Heat of Rejection	19
Leveling the Ice Machine	19
Electrical Requirements	20
Water Service/Drains	21
Water Supply.....	21
Water Inlet Lines	21
Drain Connections	22
Cooling Tower Applications.....	22
Water Supply and Drain Line Sizing/ Connections	23
Remote Condenser.....	24

Maintenance

Interior Cleaning and Sanitizing	29
General	29
Cleaning and Sanitizing Procedure.....	29
Toggle Switch Operation	30
Remove Parts for Cleaning.....	34
Preventative Maintenance Cleaning	36
Ice Machine Inspection	37
Cleaning the Condenser	38
Removal from Service/Winterization	39
Air-cooled Models.....	39
Water-cooled Models.....	39

Operation

Ice Making Sequence of Operation	41
Control Board Timers	42
Safety Limits	43
Energized Parts Chart.....	45
Operational Checks	47
Ice Thickness Check	47

Troubleshooting

Control Board Test Mode	49
Diagnosing an Ice Machine that Will Not Run ..	50
Ice Machine Does Not Cycle Into Harvest when Water Loses Contact with the Harvest Float Switch	51
Ice Machine Cycles Into Harvest Before Water Loses Contact with the Harvest Float Switch ..	53
Ice Production Check	54
Installation/Visual Inspection Checklist	55
Water System Checklist	56
Ice Formation Pattern	57
Safety Limits	60
Analyzing Discharge Pressure	67
Analyzing Suction Pressure	69
Harvest Valve	73
Comparing Evaporator Inlet/Outlet Temperatures	77
Discharge Line Temperature Analysis	78
Refrigeration Component Diagnostics	80
Procedure.....	81
Final Analysis.....	82
Refrigeration Component Diagnostic Chart ..	83

Component Check Procedures

Main Fuse	87
Bin Switch	88
Float Switch	90
Compressor Electrical Diagnostics	92
Fan Cycle Control	94
High Pressure Cutout (HPCO) Control	95
Refrigeration Components	96
Head Pressure Control Valve	96
Freeze Cycle Operation All Models	97
Harvest Cycle Operation	97
HARVEST PRESSURE REGULATING (HPR)	
SYSTEM REMOTE CONDENSER ONLY	100
Water Regulating Valve	103
Refrigerant Recovery/Evacuation	104
Definitions	104
Refrigerant Re-use Policy	105
Recovery and Recharging Procedures	107
Remote Condenser Model Procedure	110
Remote Charging Procedures	112
System Contamination Cleanup	113
Determining Severity of Contamination...	113
Mild System Contamination Cleanup Procedure	115
Severe System Contamination Cleanup Procedure	116
Replacing Pressure Controls without Removing Refrigerant Charge	117
Refrigerant Amount	119

Charts

Cycle Times, 24 Hr. Ice Production and Refrigerant Pressure Charts	121
K0250A Self-contained Air-cooled	122
K0350A Self-contained Air-cooled	123
K0350W Self-contained Water-cooled	124
K0420A Self-contained Air-cooled	125
K0420W Self-contained Water-cooled	126
K0500W Self-contained Water-cooled	128
K0600A Self-contained Air-cooled	129
K0600W Self-contained Water-cooled	130
K1000A Self-contained Air-cooled	131
K1000W Self-contained Water-cooled	132
K1000N Remote Air-cooled	133
K1350A Self-contained Air-cooled	134
K1350W Self-contained Water-cooled	135
K1350N Remote Air-cooled	136
K1800A Self-contained Air-cooled	137
K1800N Remote Air-cooled	138

Diagrams

Wiring Diagrams	139
K0250, K0350, K0420, K0500, K0600, K1000 1 Ph Self-contained Air/Water-cooled	140
K1000 1Ph Remote Air-cooled Condenser .	142
K1350, K1800 1 Ph Self-contained Air/Water-cooled	144
K1350, K1800 3Ph Self-contained Air/Water-cooled	146
K1350, K1800 1 Ph Remote Air-cooled Condenser	148
K1350, K1800 3 Ph Remote Air-cooled Condenser	150
Electronic Control Board	152
Refrigeration Tubing Schematics	153
Self-contained Air or Water-cooled	153
Remote Air-cooled	154

General Information

Model Numbers

This manual covers the following models:

Self-Contained Air-Cooled	Self-Contained Water-Cooled	Remote
KD0250A	----	----
KY0250A	----	----
KD0350A	KD0350W	----
KY0350A	KY0350W	----
KD0420A	KD0420W	----
KY0420A	KY0420W	----
KD0500A	KD0500W	----
KY0500A	KY0500W	----
KD0600A	KD0600W	----
KY0600A	KY0600W	----
KD1000A	KD1000W	KY1000N
KY1000A	KY1000W	KD1000N
KD1350A	KD1350W	KY1350N
KY1350A	KY1350W	KD1350N
KD1800A	KD1800W	KY1800N
KY1800A	KY1800W	KD1800N

Ice Machine Warranty Information

For warranty information visit:

<http://www.manitowocice.com/Service/Warranty>

- Warranty Verification
- Warranty Registration
- View and download a copy of the warranty Owner Warranty Registration Card

Warranty coverage begins the day the ice machine is installed.

How to Read a Model Number

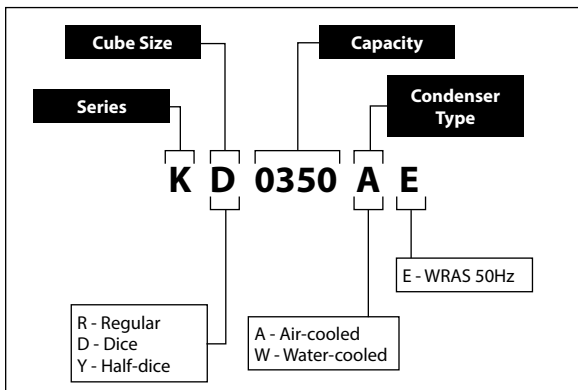

⚠ Warning

An ice machine contains high voltage electricity and refrigerant charge. Repairs are to be performed by properly trained refrigeration technicians aware of the dangers of dealing with high voltage electricity and refrigerant under pressure.

Installation

Location of Ice Machine

The location selected for the ice machine must meet the following criteria. If any of these criteria are not met, select another location.

- The location must be indoors.
- The location must be free of airborne and other contaminants.
- Air temperature: Must be at least 40°F (4°C) but must not exceed 110°F (43.4°C).
- The location must not be near heat-generating equipment or in direct sunlight.
- The location must be capable of supporting the weight of the ice machine and a full bin of ice.
- The location must allow enough clearance for water, drain, and electrical connections in the rear of the ice machine.
- The location must not obstruct airflow through or around the ice machine (condenser air flow is in the back and out the sides). Refer to the chart for clearance requirements.
- The ice machine must be protected if it will be subjected to temperatures below 32°F (0°C). Failure caused by exposure to freezing temperatures is not covered by the warranty.

Ice Machine Clearance Requirements

Warning

Do not obstruct ice machine vents or openings.

K0250	Self-Contained Air-Cooled	Self-Contained Water-Cooled
Top/Sides	12" (30.5 cm)	n/a
Back	5" (12.7 cm)*	n/a

K0350 - K0420 K0500 - K0600 K1000 - K1350	Self-Contained Air-Cooled	Water-Cooled and Remote
Top/Sides	8" (20.3 cm)	8" (20.3 cm)
Back	5" (12.7 cm)	5" (12.7 cm)

Caution

The ice machine must be protected if it will be subjected to temperatures below 32°F (0°C). Failure caused by exposure to freezing temperatures is not covered by the warranty.

Ice Machine Heat of Rejection

Series Ice Machine	Heat of Rejection ¹	
	Air Conditioning ²	Peak
K0250	4600	5450
K0350	3800	6000
K0420	5400	6300
K0500	5300	6100
K0600	9000	13900
K1000	16250	18600
K1350	28300	34300
K1800	28800	34700

1 B.T.U./Hour

2 Because the heat of rejection varies during the ice making cycle, the figure shown is an average.

Ice machines, like other refrigeration equipment, reject heat through the condenser. It is helpful to know the amount of heat rejected by the ice machine when sizing air conditioning equipment where self-contained air-cooled ice machines are installed.

Leveling the Ice Machine

1. The leveling legs must be screwed into the bottom of the bin as far as possible.

Caution

The legs must be screwed in tightly to prevent them from bending.

2. Move the bin into its final position.
3. Use a level on top of the bin. Adjust each foot as necessary and level from front to back and side to side.

Electrical Requirements

Voltage

The maximum allowable voltage variation is $\pm 10\%$ of the rated voltage on the ice machine model/serial number plate at start-up (when the electrical load is highest).

Fuse/Circuit Breaker

A separate fuse/circuit breaker must be provided for each ice machine.

Total Circuit Ampacity

The total circuit ampacity is used to help select the wire size of the electrical supply.

The wire size (or gauge) is also dependent upon location, materials used, length of run, etc., so it must be determined by a qualified electrician.

Refer to ice machine data plate, for electrical requirements. The ice machine data plate information overrides all other published data.

Warning

All wiring must conform to local, state and national codes.

Warning

The ice machine must be grounded in accordance with national and local electrical code.

Water Service/Drains

WATER SUPPLY

Local water conditions may require treatment of the water to inhibit scale formation, filter sediment, and remove chlorine odor and taste.

Important

If you are installing a water filter system, refer to the Installation Instructions supplied with the filter system for ice making water inlet connections.

⚠ Warning

For ice making, connect to a potable water supply only.

WATER INLET LINES

Follow these guidelines to install water inlet lines:

- Do not connect the ice machine to a hot water supply. Be sure all hot water restrictors installed for other equipment are working. (Check valves on sink faucets, dishwashers, etc.)
- If water pressure exceeds the maximum recommended pressure, 80 psig (5.5 bar) obtain a water pressure regulator from your Koolaire distributor.
- Install a water shut-off valve for ice making potable water.
- Insulate water inlet lines to prevent condensation.

DRAIN CONNECTIONS

Follow these guidelines when installing drain lines to prevent drain water from flowing back into the ice machine and storage bin:

- Drain lines must have a 1.5-inch drop per 5 feet of run (2.5 cm per meter), and must not create traps.
- The floor drain must be large enough to accommodate drainage from all drains.
- Install a tee to vent the ice machine drain to the atmosphere.
- Insulate drain lines to prevent condensation.

COOLING TOWER APPLICATIONS

Water Cooled Models Only

A water-cooling tower installation does not require modification of the ice machine. The water regulator valve for the condenser continues to control the refrigeration discharge pressure.

It is necessary to know the amount of heat rejected, and the pressure drop through the condenser and water valves (inlet to outlet) when using a cooling tower on an ice machine.

- Water entering the condenser must not exceed 90°F (32.2°C).
- Water flow through the condenser must not exceed 5 gallons (19 liters) per minute.
- Allow for a pressure drop of 7 psig (.48 bar) between the condenser water inlet and the outlet of the ice machine.
- Water exiting the condenser must not exceed 110°F (43.3°C).

 **Caution**

Plumbing must conform to state and local codes

WATER SUPPLY AND DRAIN LINE SIZING/ CONNECTIONS

Location	Water Temperature	Water Pressure	Ice Machine Fitting	Tubing Size Up to Ice Machine Fitting
Ice Making Water Inlet	33°F (0.6°C) min. 90°F (32.2°C) max.	20 psi (1.38 bar) min. 80 psi (5.5 bar) max.	3/8" Female Pipe Thread	3/8" (9.5 mm) min. inside diameter
Condenser Water Inlet	33°F (0.6°C) min. 90°F (32.2°C) max.	20 psi (1.38 bar) min. 150 psi (10.3 bar) max.	3/8" Female Pipe Thread	3/8" (9.5 mm) min. inside diameter
Condenser Water Drain	—	—	3/8" Female Pipe Thread	3/8" (9.5 mm) min. inside diameter

REMOTE CONDENSER

Ice Machine	Remote Single Circuit Condenser	Line Set*
K1000	KC1000	RTK-20-R410A RTK-35-R410A RTK-50-R410A
K1350 K1800	KC1395	RLK-20-R410A RLK-35-R410A RLK-50-R410A

*Line Set	Discharge Line	Liquid Line
RTK	1/2" (1.27 cm)	5/16" (.79 cm)
RLK	1/2" (1.27 cm)	3/8" (.95 cm)

Air Temperature Around the Condenser	
Minimum	Maximum
-20°F (-29°C)	120°F (49°C)

Additional Refrigerant Charge For 51' to 100' Line Sets

Ice Machine	Condenser	Additional Amount of Refrigerant To Be Added To The Nameplate Charge
K1000	KC1000	2 lbs - 907g
K1350 K1800	KC1395	2 lbs - 907g 2 lbs - 907g

Calculating Allowable Lineset Distance

Line Set Length

The maximum length is 100' (30.5 m).

Line Set Rise/Drop

The maximum rise is 35' (10.7 m).

The maximum drop is 15' (4.5 m).

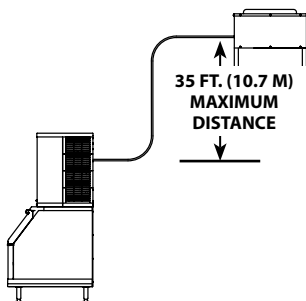

35 ft. (10.7 m) Rise: The maximum distance the Condenser or Condensing Unit can be above the ice machine.

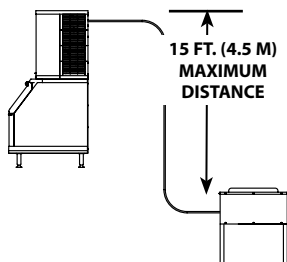

15 ft. (4.5 m) Drop: The maximum distance the Condenser or Condensing Unit can be below the ice machine.

Calculated Line Set Distance

The maximum calculated distance is 150' (45.7 m).

Line set rises, drops, horizontal runs (or combinations of these) in excess of the stated maximums will exceed compressor start-up and design limits. This will cause poor oil return to the compressor.

Make the following calculations to make sure the line set layout is within specifications.

1. Insert the **measured rise** into the formula below. Multiply by 1.7 to get the calculated rise. (Example: A condenser located 10 feet above the ice machine has a **calculated rise** of 17 feet.)
2. Insert the **measured drop** into the formula below. Multiply by 6.6 to get the calculated drop. (Example. A condenser located 10 feet below the ice machine has a **calculated drop** of 66 feet.)
3. Insert the **measured horizontal distance** into the formula below. No calculation is necessary.
4. Add together the **calculated rise, calculated drop, and horizontal distance** to get the **total calculated distance**. If this total exceeds 150' (45.7 m), move the condenser to a new location and perform the calculations again.

Maximum Line Set Distance Formula

Step 1

Measured Rise _____ X 1.7 = _____ Calculated Rise
(35 ft. Max)

Step 2

Measured Drop _____ X 6.6 = _____ Calculated Drop
(15 ft. Max.)

Step 3

Measured Horizontal Distance = _____ Horizontal
(100 ft. Max.) Distance

Step 4

Total Calculated Distance = _____ Total Calculated
(150 ft. Max.) Distance

THIS PAGE INTENTIONALLY LEFT BLANK

Maintenance

Interior Cleaning and Sanitizing

GENERAL

Clean and sanitize the ice machine every six months for efficient operation. If the ice machine requires more frequent cleaning and sanitizing, consult a qualified service company to test the water quality and recommend appropriate water treatment.

The ice machine must be taken apart for cleaning and sanitizing.

Caution

Use only Manitowoc approved Ice Machine Cleaner (part number 9405463) and Sanitizer (part number 9405653). It is a violation of Federal law to use these solutions in a manner inconsistent with their labeling. Read and understand all labels printed on bottles before use.

CLEANING AND SANITIZING PROCEDURE

Ice machine cleaner is used to remove lime scale and mineral deposits. Ice machine sanitizer disinfects and removes algae and slime.

TOGGLE SWITCH OPERATION

Moving the toggle switch to clean will start a Clean cycle.

- **Setting the ice machine to stop after the clean cycle:** Place the toggle switch in the clean position. The ice machine will stop after the clean cycle.
- **Pausing the cleaning cycle:** Move the toggle switch to Off. Moving the toggle switch to clean will restart the clean cycle.
- **Setting the ice machine to start ice making after the clean cycle:** Place the toggle switch in the Ice position more than 2 minutes into the clean cycle.

Step 1 Place the toggle switch in the clean position after ice falls from the evaporator at the end of a Harvest cycle. Or, place the toggle switch in the off position and allow the ice to melt off the evaporator.

Caution

Never use anything to force ice from the evaporator. Damage may result.

Step 2 Remove all ice from the bin.

Warning

Wear rubber gloves and safety goggles (and/or face shield) when handling Ice Machine Cleaner or Sanitizer.

 **Caution**

Do not mix Ice Machine Cleaner and Sanitizer solutions together. It is a violation of Federal law to use these solutions in a manner inconsistent with their labeling.

Step 3 To start a cleaning cycle, move the toggle switch to Clean. Water will flow through the water dump valve and down the drain. Wait until the water trough refills, then add the proper amount of ice machine cleaner to the water trough.

Model	Amount of Cleaner
K0250 K0350 K0420	3 ounces (90 ml)
K0500 K0600 K1000	5 ounces (150 ml)
K1350 K1800	9 ounces (265 ml)

Step 4 Wait until the clean cycle is complete (approximately 24 minutes) then place the toggle switch in the off position and disconnect power and water supplies to the ice machine.

Step 5 Remove parts for cleaning. Refer to the proper parts removal for your machine. Continue with Step 6 when the parts have been removed.

Step 6 Mix a solution of cleaner and lukewarm water. Depending on the amount of mineral buildup, a larger quantity of solution may be required. Use the ratio in the table below to mix enough solution to thoroughly clean all parts.

Solution Type	Water	Mixed with
Cleaner	1 gal. (4 l)	16 oz (500 ml) cleaner

Step 7 Use half of the cleaner/water solution to clean all components. The cleaner solution will foam when it contacts lime scale and mineral deposits; once the foaming stops use a soft bristle brush, sponge or cloth (not a wire brush) to carefully clean the parts. Soak the parts for 5 minutes (15 – 20 minutes for heavily scaled parts). Rinse all components with clean water.

Step 8 While components are soaking, use half of the cleaner/water solution to clean all foodzone surfaces of the ice machine and bin. Use a nylon brush or cloth to thoroughly clean the following ice machine areas:

- Evaporator plastic parts – including top, bottom and sides
- Bin bottom, sides and top
- Rinse all areas thoroughly with clean water.

Step 9 Mix a solution of sanitizer and warm water.

Solution Type	Water	Mixed With
Sanitizer	3 gal. (12 l)	2 oz (60 ml) sanitizer

Step 10 Use half of the sanitizer/water solution to sanitize all removed components. Use a spray bottle to liberally apply the solution to all surfaces of the removed parts or soak the removed parts in the sanitizer/water solution. Do not rinse parts after sanitizing.

Step 11 Use half of the sanitizer/water solution to sanitize all foodzone surfaces of the ice machine and bin. Use a spray bottle to liberally apply the solution. When sanitizing, pay particular attention to the following areas:

- Evaporator plastic parts - including top, bottom and sides
- Bin bottom, sides and top

Do not rinse the sanitized areas.

Step 12 Replace all removed components.

Step 13 Wait 25 minutes.

Step 14 Reapply power and water to the ice machine and place the toggle switch in the ice position.

Step 15 Water will flow through the water dump valve and down the drain. Wait until the water trough refills, then add the proper amount of ice machine sanitizer to the water trough.

Model	Amount of Sanitizer
K0250 K0350 K0420 K0500 K0600 K1000	3 ounces (90 ml)
K1350 K1800	6 ounces (180 ml)

Wait until the sanitize cycle is complete (approximately 24 minutes) then place the toggle switch in the ice position to start ice making.

REMOVE PARTS FOR CLEANING

Warning

Disconnect electric power to the ice machine at the electric switch box before proceeding.

1. Remove the water curtain
 - Gently flex the curtain in the center and remove it from the right side.
 - Slide the left pin out.
2. Remove the water trough
 - Depress tabs on right and left side of the water trough.
 - Allow front of water trough to drop as you pull forward to disengage the rear pins.
3. Remove the ice thickness and harvest float switches
 - Pull the float switch straight down to disengage.
 - Lower the float switch until the wiring connector is visible. y
 - Disconnect the wire lead from the float switch.
 - Remove the float switch from the ice machine.
4. Remove the water distribution tube

NOTE: Distribution tube thumbscrews are retained to prevent loss. Loosen thumbscrews but do not pull thumbscrews out of distribution tube.

- Loosen the two outer screws (do not remove screws completely they are retained to prevent loss) and pull forward on the distribution tube to release from slip joint.
- Disassemble distribution tube by loosening the two (2) middle thumbscrews and dividing the distribution tube into two pieces.
- Proceed to page 32 Step 6.

5. Remove the Water Trough

- Depress tabs on right and left side of the water trough.
- Allow front of water trough to drop as you pull forward to disengage the rear pins.
- Remove the water trough from the bin area.

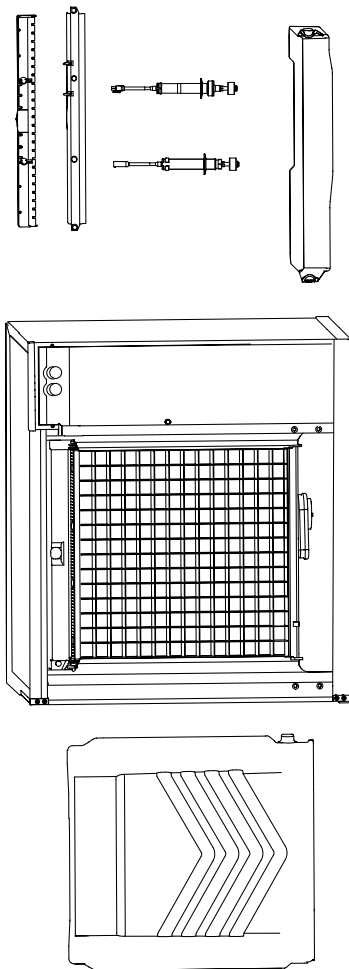

Preventative Maintenance Cleaning

This cleaning procedure can be performed between the bi-annual cleaning and sanitizing cycles. This procedure does not require removing the ice from the bin.

Step 1 Place the toggle switch in the off position after ice falls from the evaporator at the end of a Harvest cycle. Or, place the toggle switch in the off position and allow the ice to melt off the evaporator.

Caution

Never use anything to force ice from the evaporator. Damage may result.

Warning

Wear rubber gloves and safety goggles (and/or face shield) when handling Ice Machine Cleaner or Sanitizer.

Step 2 To start a cleaning cycle, place the toggle switch in the clean position. Water will flow through the water dump valve and down the drain. Wait until the water trough refills, then add the proper amount of ice machine cleaner to the water trough.

Model	Amount of Cleaner
K0250 K0350 K0420	3 ounces (90 ml)
K0500 K0600 K1000	5 ounces (150 ml)
K1350 K1800	9 ounces (265 ml)

Step 3 Wait until the clean cycle is complete (approximately 24 minutes) then place the toggle switch in the off position.

Ice Machine Inspection

Check all water fittings and lines for leaks. Also, make sure the refrigeration tubing is not rubbing or vibrating against other tubing, panels, etc.

There must be adequate airflow through and around the ice machine to maximize ice production and ensure long component life.

Exterior Cleaning

Clean the area around the ice machine as often as necessary to maintain cleanliness and efficient operation.

Sponge any dust and dirt off the outside of the ice machine with mild soap and water. Wipe dry with a clean, soft cloth.

Cleanup any fallen ice or water spills as they occur.

Cleaning the Condenser

General

Warning

Disconnect electric power to the ice machine head section and the remote condensing unit at the electric service switches before cleaning the condenser.

A dirty condenser restricts airflow, resulting in excessively high operating temperatures. This reduces ice production and shortens component life.

- Clean the condenser at least every six months.

Warning

The condenser fins are sharp. Use care when cleaning them.

- Shine a flashlight through the condenser to check for dirt between the fins.
- Blow compressed air or rinse with water from the inside out (opposite direction of airflow).
- If dirt still remains call a service agent to clean the condenser.

Removal from Service/Winterization

AIR-COOLED MODELS

1. Clean and sanitize the ice machine.
2. Place the toggle switch in the off position to turn off the ice machine.
3. Turn off the water supply, disconnect and drain the incoming ice-making water line at the rear of the ice machine and drain the water trough.
4. Energize the ice machine, wait one minute for the water inlet valve to open and blow compressed air in both the incoming water and the drain openings in the rear of the ice machine to remove all water.
5. Place the toggle switch in the off position and disconnect the electric power at the circuit breaker or the electric service switch.
6. Fill spray bottle with sanitizer and spray all interior food zone surfaces. Do not rinse and allow to air dry.
7. Replace all panels.

WATER-COOLED MODELS

1. Perform Steps 1 – 6 under “Air-Cooled Models.”
2. Disconnect the incoming water and drain line from the water-cooled condenser.
3. Energize the ice machine in the freeze cycle. The increasing refrigerant pressure will open the water regulating valve.
4. Blow compressed air through the condenser until no water remains.

THIS PAGE INTENTIONALLY LEFT BLANK

Operation

Ice Making Sequence of Operation

NOTE: The toggle switch must be in the ON position and the water curtain must be closed before the ice machine will start.

Water Purge Cycle

The ice machine purges any remaining water from the water trough down the drain.

Freeze Cycle

Prechill - The refrigeration system chills the evaporator before water flow over the evaporator starts. The water inlet valve energizes during the pre-chill and remains on until the ice thickness float switch is satisfied.

Freeze - Water flowing across the evaporator freezes and builds ice on the evaporator. After a sheet of ice has formed, the Harvest float switch signals the control board to start a harvest cycle.

Harvest Cycle

Any remaining water is purged down the drain as refrigerant gas warms the evaporator. When the evaporator warms, the sheet of cubes slides off the evaporator and into the storage bin. If all cubes fall clear of the water curtain, the ice machine starts another freeze cycle.

Full Bin Cycle

If the water curtain is held open by ice cubes the ice machine shuts off. When the water curtain closes the ice machine starts a new cycle at the water purge.

CONTROL BOARD TIMERS

- The ice machine is locked into the freeze cycle for 6 minutes before a harvest cycle can be initiated.
- The freeze time lock in feature is bypassed on the initial cycle (manual start or after a full bin/safety limit condition).
- If the harvest float switch is in the down position for 10 continuous seconds during the start of a freeze cycle, a harvest sequence is initiated.
- The maximum freeze time is 60 minutes at which time the control board automatically initiates a harvest sequence.
- The maximum harvest time is 3.5 minutes. The control board automatically initiates a freeze sequence when these times are exceeded.
- The ice machine will continue to fill with water for up to six minutes, or until the high water float opens for 5 continuous seconds. The control board will energize the water inlet valve one more time 3 minutes into the freeze cycle.

SAFETY LIMITS

Safety limits are stored and indicated by the control board. The number of cycles required to stop the ice machine varies for each safety limit.

Safety limits can be reset by cycling the toggle switch Off/On and starting a new ice making cycle.

A safety limit is indicated by a flashing light on the control board.

Safety Limit 1

If the freeze time reaches 60 minutes, the control board automatically initiates a harvest cycle.

- After 3 consecutive 60 minute cycles control board light SL#1 light will flash on/off at 1 second intervals.
- If 6 consecutive 60-minute freeze cycles occur, the ice machine stops and the SL#1 light on the control board will be on continuously.

Safety Limit 2

If the harvest time reaches 3.5 minutes, the control board automatically returns the ice machine to the freeze cycle.

- If three consecutive 3.5 minute harvest cycles occur the SL#2 light on the control board will flash on/off at 1 second intervals. After 75 consecutive 3.5 minutes harvest cycles the SL#2 light will be energized continuously.
- If 100 consecutive 3.5 minute harvest cycles occur, the ice machine stops and the SL#2 light on the control board will be on continuously.

Safety Limit 3

If the harvest float switch hasn't opened for 10 continuous seconds within 4 minutes of the water inlet valve energizing the ice machine stops.

- Safety Limit 3 is bypassed on the initial cycle (manual start or after a full bin/safety limit condition). For all subsequent cycles the ice machine stops for 30 minutes when the water inlet valve is energized for 4 minutes and the harvest float valve didn't open. Control board lights SL#1 and SL#2 will flash on/off at 1 second intervals.
- The ice machine automatically restarts at the end of the 30 minute delay period and stops flashing the control board lights.
- If 100 consecutive failures occur the ice machine stops and the SL#1 & SL#2 lights flash on/off at 1 second intervals.
- SL#1 & SL#2 will flash 3 times on startup and automatically erase after 100 normal cycles.

ENERGIZED PARTS CHART

Self-Contained Ice Machines

ICE MAKING SEQUENCE OF OPERATION	Water Pump	Harvest Valve	Water Inlet Valve	Dump Valve	Compressor & Condenser Fan Motor*	Harvest Float Switch	Ice Thickness Float Switch	Length of Time
Initial Start-up 1a. Water purge 1b. Delay period	on	on	off	on	off	closed	closed	45 seconds
	off	off	off	off	off	closed	closed	5 seconds
2. Refrigeration System Start-up 2a. Equalize Pressure	off	on	off	off	off	closed	closed	5 seconds
	off	on	off	off	on	closed	closed	5 seconds
Freeze Sequence 3. Pre chill	off	off	on	off	on	open	closed	120 Seconds initial cycle Thereafter 60 seconds

ICE MAKING SEQUENCE OF OPERATION	Water Pump	Harvest Valve	Water Inlet Valve	Dump Valve	Compressor & Condenser Fan Motor*	Harvest Float Switch	Ice Thickness Float Switch	Length of Time
4. Freeze	on	off	on	off	on	open then closed	closed then open	Until Harvest Float Switch closes for 10 continual seconds
Harvest Sequence	on	on	off	on	on	closed	closed	45 seconds
5. Water Purge	off	on	off	off	on	closed	closed	Bin switch activation
6. Harvest	off	off	off	off	off	closed	closed	Until bin switch re-closes
7. Automatic Shut-off	off	off	off	off	off	closed	closed	

* Condenser Fan Motor: The fan motor is wired through a fan cycle pressure control; therefore, it may cycle on and off.

Operational Checks

ICE THICKNESS CHECK

After a harvest cycle, inspect the ice cubes in the ice storage bin. The ice bridge connects the ice cubes and must be set to maintain an ice bridge thickness of 1/8" (3 mm). To adjust the thickness of the bridge refer to ice thickness adjustment.

The ice thickness float switch is factory-set to maintain the ice bridge thickness at 1/8" (3 mm).

NOTE: Make sure the water curtain is in place when performing this check. It prevents water from splashing out of the water trough.

1. Inspect the bridge connecting the cubes. It should be about 1/8" (3 mm) thick.
2. If adjustment is necessary, turn the ice thickness float switch clockwise to increase bridge thickness, counterclockwise to decrease bridge thickness. Adjust to achieve a 1/8" (3 mm) bridge thickness.

NOTE: The float can be adjusted with a 3/4" wrench while the water trough is in-place. Test run two cycles to verify ice bridge thickness.

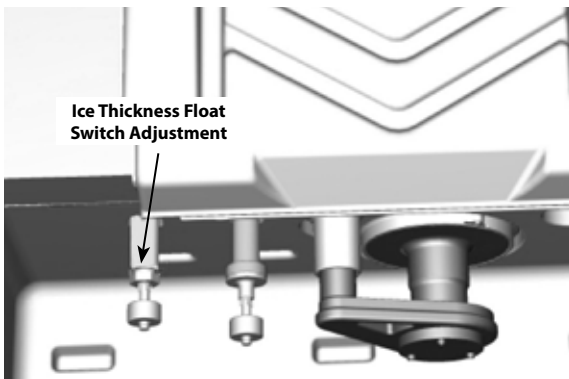

THIS PAGE INTENTIONALLY LEFT BLANK

Troubleshooting

Control Board Test Mode

NOTE: The water curtain/bin switch can be open or closed and does not affect the operation of the test mode.

To enter the test mode, move the toggle switch to off, then press and hold the test button on the control board for 3 seconds. The control board test mode performs the following functions for a 2-minute time period:

- Energizes all control board relays
- Energizes all control board lights

After 2 minutes, the control board will automatically initiate and complete one ice-making cycle, then stop.

Canceling a test cycle:

To cancel a test cycle, press the test button a second time.

Restarting a test cycle:

The test cycle will restart each time the test button is pressed for a 3-second time period.

Diagnosing an Ice Machine that Will Not Run

Warning

High (line) voltage is applied to the control board at all times. Removing the control board fuse or pressing the power button will not remove the power supplied to the control board.

1. Verify primary voltage is supplied to ice machine and the fuse/circuit breaker is closed.
2. Verify control board fuse is okay.

NOTE: If any control board lights are on, the fuse is okay.

3. Verify the bin switch functions properly. A defective bin switch can falsely indicate a full bin of ice.
4. Verify toggle switch functions properly. A defective toggle switch may keep the ice machine in the OFF mode. Refer to toggle switch diagnostics when Steps 1 – 3 test good.
5. Be sure Steps 1 – 4 were followed thoroughly. Intermittent problems are not usually related to the control board. Replace control board if toggle switch operation is correct.

Ice Machine Does Not Cycle Into Harvest when Water Loses Contact with the Harvest Float Switch

NOTE: The ice machine will make a thick or double slab when a new freeze cycle is started with ice already present on the evaporator.

Two of the most common scenarios are:

- Power is cycled off/on with ice on the evaporator.
- The water curtain/bin switch is opened/closed in the harvest cycle before the ice releases.

Remove all ice from the evaporator before starting diagnostic procedures.

Freeze Time Lock-In Feature

The ice machine control system incorporates a freeze time lock-in feature. This prevents the ice machine from short cycling in and out of harvest. The control board locks the ice machine in the freeze cycle for six minutes. After six minutes a harvest cycle can be initiated. To allow the service technician to initiate a harvest cycle without delay, this feature is not used on the first cycle after moving the toggle switch to OFF and back to ON.

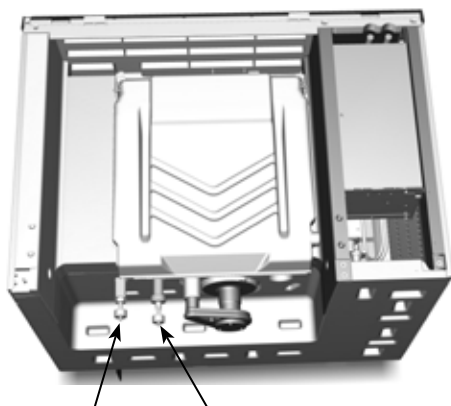

ICE THICKNESS FLOAT
SWITCH

HARVEST FLOAT SWITCH

Step 1 Disconnect power to the ice machine, remove the electrical panel to allow viewing of the control board lights. Disconnect the harvest float switch wire from the control board and place a jumper on the control board harvest switch terminals.

Step 2 Bypass the freeze time lock-in feature by moving the toggle switch Off/On to cycle the ice machine on. Wait until water flows over the evaporator, then refer to chart.

Result	Correction
10 seconds into the freeze cycle the ice machine cycles from freeze to harvest and the control board harvest light energizes.	The ice thickness float switch, connectors or wiring are causing the malfunction.
The harvest light comes on, but the ice machine remains in the freeze cycle.	The ice machine is in a 6 minute freeze lock - Cycle on/off and retest.
The harvest light stays off and the ice machine remains in freeze.	Replace the control board.

Ice Machine Cycles Into Harvest Before Water Loses Contact with the Harvest Float Switch

Step 1 Disconnect power to the ice machine, remove the electrical panel to allow viewing of the control board lights and disconnect the harvest float switch from the control board.

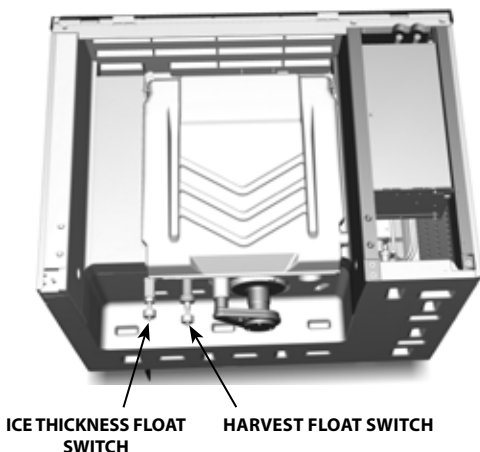

Step 2 Reapply power and move the toggle switch to Ice to bypass the freeze time lock-in feature. Wait until water flows over the evaporator, then refer to chart.

Result	Correction
The harvest light does not come on and the ice machine stays in freeze.	The ice thickness float switch, connectors or wiring are causing the malfunction. Refer to float switch diagnostics.
10 seconds into the freeze cycle the ice machine cycles from freeze to harvest and the control board harvest light energizes.	Replace the control board.

Ice Production Check

The amount of ice a machine produces directly relates to the operating water and air temperatures. This means an ice machine with a 70°F (21°C) ambient temperature and 50°F (10°C) water produces more ice than the same ice machine with 90°F (32°C) ambient and 70°F (21°C) water.

1. Determine the ice machine operating conditions:
Air temp entering condenser: _____°
Air temp around ice machine: _____°
Water temp entering sump trough: _____°
2. Refer to the appropriate 24-Hour Ice Production Chart. Use the operating conditions determined in Step 1 to find published 24-Hour Ice Production: _____
 - Times are in minutes.
Example: 1 min. 15 sec. converts to 1.25 min.
(15 seconds ÷ 60 seconds = .25 minutes)
 - Weights are in pounds.
Example: 2 lb. 6 oz. converts to 2.375 lb.
(6 oz. ÷ 16 oz. = .375 lb.)
3. Perform an ice production check using the formula below.

1. _____	+	_____	=	_____
Freeze Time		Harvest Time		Total Cycle Time
2. _____	÷	_____	=	_____
Minutes in 24 Hrs.		Total Cycle Time		Cycles per Day
3. _____	x	_____	=	_____
Weight of One Harvest		Cycles per Day		Actual 24-Hour Production

Weighing the ice is the only 100% accurate check.

4. Compare the results of Step 3 with Step 2. Ice production is normal when these numbers match closely. If they match closely, determine if:
 - Another larger ice machine is required.
 - Relocating the existing equipment to lower the load conditions is required.

Contact the local distributor for information on available options and accessories.

Installation/Visual Inspection Checklist

Ice machine is not level

- Level the ice machine

Condenser is dirty

- Clean the condenser

Water filtration is plugged (if used)

- Install a new water filter

Water drains are not run separately and/or are not vented

- Run and vent drains according to the Installation Manual

Water System Checklist

A water-related problem often causes the same symptoms as a refrigeration system component malfunction.

Example: A water dump valve leaking during the freeze cycle, a system low on charge, and a starving TXV have similar symptoms.

Water system problems must be identified and eliminated prior to replacing refrigeration components.

Water area (evaporator) is dirty

- Clean as needed

Water inlet pressure not between 20 and 80 psig (1–5 bar, 138–552 kPa)

- Install a water regulator valve or increase the water pressure

Incoming water temperature is not between 35°F (1.7°C) and 90°F (32.2°C)

- If too hot, check the hot water line check valves in other store equipment

Water filtration is plugged (if used)

- Install a new water filter

Vent tube is not installed on water outlet drain

- See Installation Instructions

Hoses, fittings, etc., are leaking water

- Repair/replace as needed

Water valve is stuck open, closed or is leaking

- Clean/replace as needed

Water is spraying out of the sump trough area

- Stop the water spray

Uneven water flow across the evaporator

- Clean the ice machine

Water is freezing behind the evaporator

- Correct the water flow

Plastic extrusions and gaskets are not secured to the evaporator

- Remount/replace as needed

Ice Formation Pattern

Evaporator ice formation pattern analysis is helpful in ice machine diagnostics.

Analyzing the ice formation pattern alone cannot diagnose an ice machine malfunction. However, when this analysis is used along with the Refrigeration System Operational Analysis Table, it can help diagnose an ice machine malfunction.

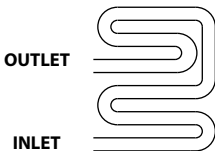

Example of Evaporator Tubing Routing

Normal Ice Formation

Ice forms across the entire evaporator surface.

At the beginning of the Freeze cycle, it may appear that more ice is forming on the inlet of the evaporator than at the outlet. At the end of the Freeze cycle, ice formation at the outlet will be close to, or just a bit thinner than, ice formation at the inlet. The dimples in the cubes at the outlet of the evaporator may be more pronounced than those at the inlet. This is normal.

If ice forms uniformly across the evaporator surface, but does not do so in the proper amount of time, this is still considered a normal ice fill pattern.

Extremely Thin at Evaporator Outlet

There is no ice, or a considerable lack of ice formation on the outlet of the evaporator.

Examples: No ice at all at the outlet of the evaporator, but ice forms at the inlet half of the evaporator. Or, the ice at the outlet of the evaporator reaches the correct thickness, but the outlet of the evaporator already has 1/2" to 1" of ice formation.

Extremely Thin at Evaporator Inlet

There is no ice, or a considerable lack of ice formation at the inlet of the evaporator. Examples: The ice at the outlet of the evaporator reaches the correct thickness, but there is no ice formation at all at the inlet of the evaporator.

No Ice Formation

The ice machine operates for an extended period, but there is no ice formation at all on the evaporator.

Evaporator Tubing Routing

Routing of the tubing on the back of the evaporator determines the ice fill pattern failure mode.

One Evaporator, One TXV Models

The evaporator outlet tubing does not exit directly at the top of the evaporator, but exits several inches below the top of the evaporator. Extremely Thin at the Evaporator Outlet will first be visible several inches below the top of the evaporator. Extremely Thin at Evaporator Inlet will first be visible at the bottom of the evaporator.

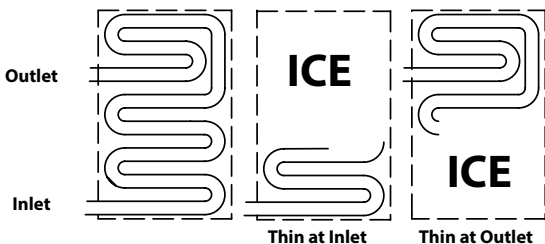

One Evaporator, Two TXV 48" Models

Tubing routing for one evaporator with two TXV's is different. The evaporator has two inlets and outlets. Fill pattern varies depending on which circuit is affected,

Extremely Thin at the Evaporator Outlet

Will first be visible 1/3 of the way down the evaporator. Only one side of the evaporator may be affected depending on failure. A TXV failure will usually show on only one side, while low on refrigerant can affect one or both sides depending on the amount of refrigerant loss and ambient temperature.

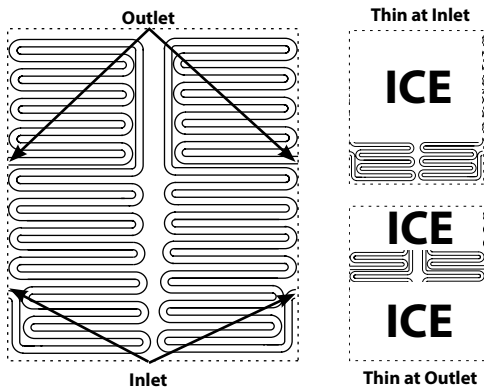

Extremely Thin at the Evaporator Inlet

Will show at the bottom of the evaporator. Depending on the failure either the entire bottom of the evaporator or one side of the bottom of the evaporator may be affected.

SAFETY LIMITS

Safety limits are stored and indicated by the control board. The number of cycles required to stop the ice machine varies for each safety limit.

Safety limits can be reset by cycling the toggle switch Off/On and starting a new ice making cycle.

A safety limit is indicated by a flashing light on the control board.

Safety Limit 1

If the freeze time reaches 60 minutes, the control board automatically initiates a harvest cycle.

- After 3 consecutive 60 minute cycles, control board light SL#1 light will flash on/off at 1 second intervals.
- If 6 consecutive 60-minute freeze cycles occur, the ice machine stops and the SL#1 light on the control board will be on continuously.

Safety Limit 2

If the harvest time reaches 3.5 minutes, the control board automatically returns the ice machine to the freeze cycle.

- If three consecutive 3.5 minute harvest cycles occur, the SL#2 light on the control board will flash on/off at 1 second intervals. After 75 consecutive 3.5 minutes harvest cycles, the SL#2 light will be energized continuously.
- If 100 consecutive 3.5 minute harvest cycles occur, the ice machine stops and the SL#2 light on the control board will be on continuously.

Safety Limit 3

If the harvest float switch hasn't opened for 10 continuous seconds within 4 minutes of the water inlet valve energizing, the ice machine stops.

- Safety Limit 3 is bypassed on the initial cycle (manual start or after a full bin/safety limit condition). For all subsequent cycles, the ice machine stops for 30 minutes when the water inlet valve is energized for 4 minutes and the harvest float valve didn't open. Control board lights SL#1 and SL#2 will flash on/off at 1 second intervals.
- The ice machine automatically restarts at the end of the 30 minute delay period and stops flashing the control board lights.
- If 100 consecutive failures occur, the ice machine stops and the SL#1 & SL#2 lights flash on/off at 1 second intervals.
- SL#1 & SL#2 will flash 3 times on start-up and automatically erase after 100 normal cycles.

Determining Which Safety Limit Stopped the Ice Machine:

1. Cycle the toggle switch Off.
2. Cycle the toggle switch On to start ice making.
3. Watch the safety limit lights.
 - One will flash corresponding to safety limits 1 or 2.
4. Safety limit 3 is indicated by both SL#1 & SL#2 flashing.

After safety limit indication, the ice machine will restart and run until a safety limit is exceeded again.

Safety Limit Notes

- A continuous run of 100 harvests automatically erases the safety limit code.
- The control board will store and indicate only one safety limit – the last one exceeded.
- If the toggle switch is cycled OFF and then ON prior to reaching the 100-harvest point, the last safety limit exceeded will be indicated.

Safety Limit Checklist

The following checklists are designed to assist the service technician in analysis. However, because there are many possible external problems, do not limit your diagnosis to only the items listed.

Safety Limit #1

Freeze time exceeds 60 minutes for 3 consecutive freeze cycles.

Possible Cause Checklist

Improper installation

- Refer to "Installation/Visual Inspection Checklist" on page 55

Water System

- Float switch or water escaping water trough
- Low water pressure (20 psig min.)
- High water pressure (80 psig max.)
- High water temperature (90°F/32.2°C max.)
- Clogged water distribution tube
- Dirty/defective water inlet valve
- Defective water pump

Electrical System

- Harvest cycle not initiated electrically
- Contactor not energizing
- Compressor electrically non-operational
- Restricted condenser air flow
- High inlet air temperature (110°F/43.3°C max.)
- Condenser discharge air re-circulation
- Dirty condenser fins
- Defective fan cycling control
- Defective fan motor
- Dirty condenser

Refrigeration System

- Non-OEM components
- Improper refrigerant charge
- Defective compressor
- TXV starving or flooding (check bulb mounting)
- Non-condensable in refrigeration system
- Plugged or restricted high side refrigerant lines or component
- Defective harvest valve

Safety Limit #2

Harvest time exceeds 3.5 minutes for 100 Consecutive harvest cycles.

Possible Cause Checklist

Improper installation

- Refer to "Installation/Visual Inspection Checklist" on page 55

Water System

- Water area (evaporator) dirty
- Dirty/defective water dump valve
- Vent tube not installed on water outlet drain
- Water freezing behind evaporator
- Plastic extrusions and gaskets not securely mounted to the evaporator

Electrical System

- Bin switch defective
- Premature harvest

Refrigeration System

- Non-OEM components
- Improper refrigerant charge
- Defective harvest valve
- TXV flooding (check bulb mounting)
- Defective fan cycling control

Safety Limit 3

The harvest float switch hasn't opened for 10 continuous seconds within 4 minutes of the water inlet valve energizing.

Possible Cause Checklist

Improper installation

- Refer to "Installation/Visual Inspection Checklist" on page 55

Water System

- Water dump valve
- Harvest float valve dirty or defective
- Low water pressure (20 psig min.)
- Dirty defective water filter (when used)
- Loss of water from sump area
- Dirty/defective water inlet valve

Electrical System

- Water inlet valve coil defective
- Harvest float valve defective

Analyzing Discharge Pressure

1. Determine the ice machine operating conditions:

Air temp. entering condenser _____

Air temp. around ice machine _____

Water temp. entering sump trough _____

2. Refer to "Cycle Times, 24 Hr. Ice Production and Refrigerant Pressure Charts" on page 269 for ice machine being checked.

Use the operating conditions determined in Step 1 to find the published normal discharge pressures.

Freeze Cycle _____

Harvest Cycle _____

3. Perform an actual discharge pressure check.

	Freeze Cycle PSIG	Harvest Cycle PSIG
Beginning of Cycle	_____	_____
Middle of Cycle	_____	_____
End of Cycle	_____	_____

4. Compare the actual discharge pressure (Step 3) with the published discharge pressure (Step 2).

The discharge pressure is normal when the actual pressure falls within the published pressure range for the ice machine's operating conditions. It is normal for the discharge pressure to be higher at the beginning of the freeze cycle (when load is greatest), then drop through out the freeze cycle.

Discharge Pressure High Checklist

Improper Installation

- Refer to "Installation/Visual Inspection Checklist" on page 55.

Condenser Air Flow

- High inlet air temperature
- Condenser discharge air re-circulation
- Dirty condenser fins
- Defective fan cycling control
- Defective fan motor

Improper Refrigerant Charge

- Overcharged
- Non-condensable in system
- Wrong type of refrigerant

Other

- Non-OEM components in system
- High side refrigerant lines/component restricted (before mid-condenser)

Freeze Cycle Discharge Pressure Low Checklist

Improper Installation

- Refer to "Installation/Visual Inspection Checklist" on page 55.

Improper Refrigerant Charge

- Undercharged
- Wrong type of refrigerant

Other

- Non-OEM components in system
- High side refrigerant lines/component restricted (before mid-condenser)
- Defective fan cycle control

NOTE: Do not limit your diagnosis to only the items listed in the checklists.

Analyzing Suction Pressure

The suction pressure gradually drops throughout the freeze cycle. The actual suction pressure (and drop rate) changes as the air and water temperature entering the ice machine changes. These variables also determine the freeze cycle times.

To analyze and identify the proper suction pressure drop throughout the freeze cycle, compare the published suction pressure to the published freeze cycle time.

NOTE: Analyze discharge pressure before analyzing suction pressure. High or low discharge pressure may be causing high or low suction pressure.

Procedure

Step																												
<p>1. Determine the ice machine operating conditions.</p> <p><i>Example:</i> <i>Air temp. entering condenser: 90°F/32.2°C</i> <i>Air temp. around ice machine: 80°F/26.7°C</i> <i>Water temp. entering water fill valve: 70°F/21.1°C</i></p>																												
<p>2A. Refer to "Cycle Time" and "Operating Pressure" charts for ice machine model being checked. Using operating conditions from Step 1, determine published freeze cycle time and published freeze cycle suction pressure.</p> <p><i>Example:</i> <i>Published freeze cycle time: 14.8 - 15.9 minutes</i> <i>Published freeze cycle suction pressure: 65 - 26 psig</i></p>																												
<p>2B. Compare the published freeze cycle time and published freeze cycle suction pressure. Develop a chart.</p> <p><i>Example:</i></p> <table><tr><td colspan="7"><u>Published Freeze Cycle Time (minutes)</u></td></tr><tr><td>1</td><td>2</td><td>4</td><td>7</td><td>10</td><td>12</td><td>14</td></tr><tr><td> </td><td> </td><td> </td><td> </td><td> </td><td> </td><td> </td></tr><tr><td>65</td><td>55</td><td>47</td><td>39</td><td>34</td><td>30</td><td>26</td></tr></table> <p><u>Published Freeze Cycle Suction Pressure (psig)</u> <i>In the example, the proper suction pressure should be approximately 39 psig at 7 minutes; 30 psig at 12 minutes; etc.</i></p>	<u>Published Freeze Cycle Time (minutes)</u>							1	2	4	7	10	12	14								65	55	47	39	34	30	26
<u>Published Freeze Cycle Time (minutes)</u>																												
1	2	4	7	10	12	14																						
65	55	47	39	34	30	26																						
<p>3. Perform an actual suction pressure check at the beginning, middle and end of the freeze cycle. Note the times at which the readings are taken.</p> <p><i>Example:</i> <i>Manifold gauges were connected to the example ice machine and suction pressure readings taken as follows: _____ PSIG</i> <i>Beginning of freeze cycle: 79 (at 1 min.)</i> <i>Middle of freeze cycle: 48 (at 7 min.)</i> <i>End of freeze cycle: 40 (at 14 min.)</i></p>																												
<p>4. Compare the actual freeze cycle suction pressure (Step 3) to the published freeze cycle time and pressure comparison (Step 2B). Determine if the suction pressure is high, low or acceptable.</p> <p><i>Example:</i> <i>In this example, the suction pressure is considered high throughout the freeze cycle. It should have been:</i> <i>Approximately 65 psig (at 1 minute) – not 79</i> <i>Approximately 39 psig (at 7 minutes) – not 48</i> <i>Approximately 26 psig (at 14 minutes) – not 40</i></p>																												

Suction Pressure High Checklist

Improper Installation

- Refer to "Installation/Visual Inspection Checklist" on page 55.

Discharge Pressure

- Discharge pressure is too high and is affecting suction pressure, refer to "Discharge Pressure High Checklist" on page 68.

Improper Refrigerant Charge

- Overcharged
- Wrong type of refrigerant
- Non-condensable in system

Other

- Non-OEM components in system
- Harvest valve leaking
- TXV flooding (check bulb mounting)
- Defective compressor

Suction Pressure Low Checklist

Improper Installation

- Refer to "Installation/Visual Inspection Checklist" on page 55.

Discharge Pressure

- Discharge pressure is too low, and is affecting suction pressure, refer to "Freeze Cycle Discharge Pressure Low Checklist" on page 68

Improper Refrigerant Charge

- Undercharged
- Wrong type of refrigerant

Other

- Non-OEM components in system
- Improper water supply over evaporator refer to "Water System Checklist" on page 56.
- Loss of heat transfer from tubing on back side of evaporator
- Restricted/plugged liquid line drier
- Restricted/plugged tubing in suction side of refrigeration system
- TXV starving

NOTE: Do not limit your diagnosis to only the items listed in the checklists.

Harvest Valve

General

The harvest valve is an electrically operated valve that opens when energized, and closes when de-energized.

Normal Operation

The valve is de-energized (closed) during the freeze cycle and energized (open) during the harvest cycle. The valve is positioned between the compressor discharge line and the evaporator and performs two functions:

1. Prevents refrigerant from entering the evaporator during the freeze cycle.

The harvest valve is not used during the freeze cycle. The harvest valve is de-energized (closed) preventing refrigerant flow from the receiver into the evaporator.

2. Allows refrigerant vapor to enter the evaporator in the harvest cycle.

During the harvest cycle, the harvest valve is energized (open) allowing refrigerant gas from the discharge line of the compressor to flow into the evaporator. The heat is absorbed by the evaporator and allows release of the ice slab.

Exact pressures vary according to ambient temperature and ice machine model. Harvest pressures can be found in the Cycle Time/24 Hour Ice Production/ Refrigerant Pressure Charts in this book.

Harvest Valve Analysis

The valve can fail in two positions:

- Valve will not open in the harvest cycle.
- Valve remains open during the freeze cycle.

VALVE WILL NOT OPEN IN THE HARVEST CYCLE

Although the circuit board has initiated a harvest cycle, the evaporator temperature remains unchanged from the freeze cycle.

VALVE REMAINS OPEN IN THE FREEZE CYCLE:

Symptoms of a harvest valve remaining partially open during the freeze cycle can be similar to symptoms of an expansion valve or compressor problem. Symptoms are dependent on the amount of leakage in the freeze cycle.

A small amount of leakage will cause increased freeze times and an ice fill pattern that is "Thin at the Outlet", but fills in at the end of the cycle.

As the amount of leakage increases, the length of the freeze cycle increases and the amount of ice at the outlet of the evaporator decreases.

Refer to the Parts Manual for proper valve application. If replacement is necessary, use only "original" replacement parts.

Use the following procedure and table to help determine if a harvest valve is remaining partially open during the freeze cycle.

1. Wait five minutes into the freeze cycle.
2. Feel the inlet of the harvest valve(s).

Important

Feeling the harvest valve outlet or across the harvest valve itself will not work for this comparison.

The harvest valve outlet is on the suction side (cool refrigerant). It may be cool enough to touch even if the valve is leaking.

3. Feel the compressor discharge line.

⚠ Warning

The inlet of the harvest valve and the compressor discharge line could be hot enough to burn your hand. Just touch them momentarily.

4. Compare the temperature of the inlet of the harvest valves to the temperature of the compressor discharge line.

Findings	Comments
<p>The inlet of the harvest valve is cool enough to touch and the compressor discharge line is hot.</p> <p style="text-align: center;">Cool & Hot</p>	<p>This is normal as the discharge line should always be too hot to touch and the harvest valve inlet, although too hot to touch during harvest, should be cool enough to touch after 5 minutes into the freeze cycle.</p>
<p>The inlet of the harvest valve is hot and approaches the temperature of a hot compressor discharge line.</p> <p style="text-align: center;">Hot & Hot</p>	<p>This is an indication something is wrong, as the harvest valve inlet did not cool down during the freeze cycle. If the compressor dome is also entirely hot, the problem is not a harvest valve leaking, but rather something causing the compressor (and the entire ice machine) to get hot.</p>
<p>Both the inlet of the harvest valve and the compressor discharge line are cool enough to touch.</p> <p style="text-align: center;">Cool & Cool</p>	<p>This is an indication something is wrong, causing the compressor discharge line to be cool to the touch. This is not caused by a harvest valve leaking.</p>

5. Record your findings on the table.

Comparing Evaporator Inlet/Outlet Temperatures

The temperatures of the suction lines entering and leaving the evaporator alone cannot diagnose an ice machine. However, comparing these temperatures during the freeze cycle, along with the Refrigeration System Operational Analysis Table, can help diagnose an ice machine malfunction.

The actual temperatures entering and leaving the evaporator vary by model, and change throughout the freeze cycle. This makes documenting the “normal” inlet and outlet temperature readings difficult. The key to the diagnosis lies in the difference between the two temperatures five minutes into the freeze cycle. These temperatures must be within 7°F (4°C) of each other.

Use this procedure to document freeze cycle inlet and outlet temperatures.

1. Use a quality temperature meter, capable of taking temperature readings on curved copper lines.
2. Attach the temperature meter sensing device to the copper lines entering and leaving the evaporator.

Important

Do not simply insert the sensing device under the insulation. It must be attached to and reading the actual temperature of the copper line.

3. Wait five minutes into the freeze cycle.
4. Record the temperatures below and determine the difference between them.

Inlet Temperature	Difference must be within 7°F (4°C) at 5 minutes into the freeze cycle	Outlet Temperature
----------------------	--	-----------------------

5. Use this with other information gathered on the Refrigeration System Operational Analysis Table to determine the ice machine malfunction.

Discharge Line Temperature Analysis

GENERAL

Knowing if the discharge line temperature is increasing, decreasing or remaining constant can be an important diagnostic tool. Maximum compressor discharge line temperature on a normally operating ice machine steadily increases throughout the freeze cycle. Comparing the temperatures over several cycles will result in a consistent maximum discharge line temperature.

Ambient air temperatures affect the maximum discharge line temperature.

Higher ambient air temperatures at the condenser = higher discharge line temperatures at the compressor.

Lower ambient air temperatures at the condenser = lower discharge line temperatures at the compressor.

Regardless of ambient temperature, the freeze cycle discharge line temperature will be higher than 150°F (66°C) on a normally operating ice machine.

PROCEDURE

Connect a temperature probe on the compressor discharge line within 6" (15 cm) of the compressor. Observe the discharge line temperature for the last three minutes of the freeze cycle and record the maximum discharge line temperature.

Discharge Line Temperature Above 150°F (66°C) at End of Freeze Cycle:

Ice machines that are operating normally will have consistent maximum discharge line temperatures above 150°F (66°C).

Verify the expansion valve sensing bulb is positioned and secured correctly.

Discharge Line Temperature Below 150°F (66°C) at End of Freeze Cycle

Ice machines that have a flooding expansion valve will have a maximum discharge line temperature that decreases each cycle.

Verify the expansion valve sensing bulb is 100% insulated and sealed airtight. Condenser air contacting an incorrectly insulated sensing bulb will cause overfeeding of the expansion valve.

Refrigeration Component Diagnostics

All electrical and water related problems must be corrected before these charts will work properly. These tables must be used with charts, checklists and other references to eliminate refrigeration components not listed and external items and problems that will cause good refrigeration components to appear defective.

The tables list four different defects that may affect the ice machine's operation.

NOTE: A low-on-charge ice machine and a starving expansion valve have very similar characteristics and are listed under the same column.

PROCEDURE

Step 1 Complete each item individually in the “Operational Analysis” column.

Enter check marks (✓) in the boxes.

Each time the actual findings of an item in the “Operational Analysis” column matches the published findings on the table, enter a check mark.

Example: Freeze cycle suction pressure is determined to be low. Enter a check mark in the “low” box.

Perform the procedures and check all information listed. Each item in this column has supporting reference material.

While analyzing each item separately, you may find an “external problem” causing a good refrigerant component to appear bad. **Correct problems as they are found. If the operational problem is found, it is not necessary to complete the remaining procedures.**

Step 2 Add the check marks listed under each of the four columns. Note the column number with the highest total and proceed to “Final Analysis.”

NOTE: If two columns have matching high numbers, a procedure was not performed properly and/or supporting material was not analyzed correctly.

FINAL ANALYSIS

The column with the highest number of check marks identifies the refrigeration problem.

Column 1 – Harvest Valve Leaking

A leaking harvest valve must be replaced.

Column 2 – Low Charge/TXV Starving

Normally, a starving expansion valve only affects the freeze cycle pressures, not the harvest cycle pressures. A low refrigerant charge normally affects both pressures. Verify the ice machine is not low on charge before replacing an expansion valve.

Add refrigerant charge in 2 oz. increments as a diagnostic procedure to verify a low charge. (Do not add more than the total charge of refrigerant.) If the problem is corrected, the ice machine is low on charge. Find the refrigerant leak.

The ice machine must operate with the nameplate charge. If the leak cannot be found, proper refrigerant procedures must still be followed. Change the liquid line drier, evacuate the system and weigh in the proper charge.

If the problem is not corrected by adding charge, the expansion valve is faulty.

Column 3 – TXV Flooding

A loose or improperly mounted expansion valve bulb causes the expansion valve to flood. Check bulb mounting, insulation, etc., before changing the valve.

Column 4 – Compressor

Replace the compressor and start components. To receive warranty credit, the compressor ports must be properly sealed by crimping and soldering them closed. Old start components must be returned with the faulty compressor.

Refrigeration Component Diagnostic Chart

	1	2	3	4
<p>Operational Analysis</p>				
<p>Ice Production</p>	<p>Published 24 hour ice production _____ Calculated (actual) 24 hour ice production _____</p> <p>NOTE: The ice machine is operating properly if the ice fill pattern is normal and ice production is within 10% of charted capacity.</p>			
<p>Installation and Water System</p>	<p>All installation and water related problems must be corrected before proceeding with chart.</p>			

Operational Analysis	1	2	3	4
Ice Formation Pattern	Ice formation is extremely thin on outlet of evaporator -or- No ice formation on entire evaporator	Ice formation extremely thin on outlet of evaporator -or- No ice formation on entire evaporator	Ice formation is normal -or- Ice formation is extremely thin on the bottom of evaporator -or- No ice formation on evaporator	Ice formation is normal -or- No ice formation on entire evaporator
Safety Limits Refer to "Analyzing Safety Limits" to eliminate all non-refrigeration problems.	Stops on safety limit: 1 or 2	Stops on safety limit: 1	Stops on safety limit: 1 or 2	Stops on safety limit: 1

Operational Analysis	1	2	3	4
Freeze Cycle Discharge Pressure <hr/> 1 minute Middle End	If discharge pressure is High or Low, refer to freeze cycle high or low discharge pressure problem checklist to eliminate problems and/or components not listed on this table before proceeding.			
Freeze Cycle Suction Pressure <hr/> 1 minute Middle End	If suction pressure is High or Low refer to freeze cycle high or low suction pressure problem checklist to eliminate problems and/or components not listed on this table before proceeding.			
	Suction pressure is High	Suction pressure is Low	Suction pressure is High	Suction pressure is High

Operational Analysis	1	2	3	4
<p>Harvest Valve</p>	<p>The harvest valve inlet is HOT and the compressor discharge line is HOT</p>	<p>The harvest valve inlet is COOL and the compressor discharge line is HOT</p>	<p>The harvest valve inlet is COOL and the compressor discharge line is COOL</p>	<p>The harvest valve inlet is COOL and the compressor discharge line is HOT</p>
<p>Discharge Line Temp. Record freeze cycle discharge line temp at the end of freeze cycle.</p>	<p>Discharge line temp 150°F (66°C) or higher at the end of freeze cycle</p>	<p>Discharge line temp 150°F (66°C) or higher at the end of freeze cycle</p>	<p>Discharge line temp less than 150°F (66°C) at the end of freeze cycle</p>	<p>Discharge line temp 150°F (66°C) or higher at the end of freeze cycle</p>
<p>Final Analysis Enter total number of boxes checked in each column.</p>	<p>Harvest Valve Leaking</p>	<p>Low On Charge -or- TXV Starving</p>	<p>TXV Flooding</p>	<p>Compressor</p>

Component Check Procedures

Main Fuse

Function

The control board fuse stops ice machine operation if electrical components fail causing high amp draw.

Specifications

- The main fuse is 250 Volt, 3.15 amp.

Warning

High (line) voltage is applied to the control board at all times. Removing the control board fuse or cycling the toggle switch Off/On will not remove the power supplied to the control board.

Check Procedure

1. If the curtain light is on with the water curtain closed, the fuse is good.

Warning

Disconnect electrical power to the entire ice machine before proceeding.

2. Remove the fuse. Check the resistance across the fuse with an ohmmeter.

Reading	Result
Open (OL)	Replace fuse
Closed (O)	Fuse is good

Bin Switch

Function

Bin switch operation is controlled by the movement of the water curtain. The bin switch has two main functions:

1. Terminating the harvest cycle and returning the ice machine to the freeze cycle.

This occurs when the bin switch is opened and closed again within 30 seconds of opening during the harvest cycle.

2. Automatic ice machine shut-off.

If the storage bin is full at the end of a harvest cycle, the sheet of cubes fails to clear the water curtain and holds it down. After the water curtain is held down for 30 seconds, the ice machine shuts off.

The ice machine remains off until enough ice is removed from the storage bin to allow the sheet of cubes to drop clear of the water curtain. As the water curtain swings back to the operating position, the bin switch closes and the ice machine restarts.

Important

The ice damper must be up (bin switch closed) to start ice making.

Check Procedure

1. Cycle the toggle switch OFF.
2. Watch the curtain light on the control board.
3. Move the water curtain upward, toward the evaporator. The bin switch must close. The curtain light "on" indicates the bin switch has closed properly.
4. Move the water curtain away from the evaporator. The bin switch must open. The curtain light "off" indicates the bin switch has opened properly.

Ohm Test

1. Disconnect the bin switch wires from the control board.
2. Connect an ohmmeter to the disconnected bin switch.
3. Cycle the bin switch open and closed numerous times by opening and closing the water curtain.

NOTE: To prevent misdiagnosis:

- Always use the water curtain magnet to cycle the switch (a larger or smaller magnet will affect switch operation).
- Watch for consistent readings when the bin switch is cycled open and closed (bin switch failure could be erratic).

Float Switch

Function

Open and close to indicate to the control board the level of water in the water trough.

Specifications

Normally closed, float operated magnetic reed switch.

The float switch contacts are closed in the down position. When water raises the float to the up position the magnet in the float opens the contacts.

Check Procedure

The ice machine uses two float switches.

Ice Thickness Float - Indicates the water level has been reached.

Harvest Float - Indicates a harvest cycle needs to be initiated.

Initial testing can be performed by viewing the control board light(s) while raising and lowering the float. The corresponding control board light must turn on and off when the float is raised and lowered.

Harvest Float Switch:

- A. The light must be on in the up position.
- B. The light must be off in the down position.

Ice Thickness Float Switch:

- A. The light must be off in the down position.
- B. The light must be on in the up position.

If the control board light does not respond to the float, proceed with Step 1 below.

1. Disconnect power to the ice machine and pull the float switch and connector through the ice machine base and disconnect.
2. Attach an ohm meter lead to each float switch wire.
3. Place the float in the down position - The float switch must be closed.
4. Place the float in the up position - The float switch must be open.
5. If the float tests good, ohm the interconnecting wires to the control board and inspect connectors.

NOTE: Make adjustments with the ice machine in the off position. Making adjustments during the freeze cycle may produce an initial sheet of ice that is thicker than future cycles.

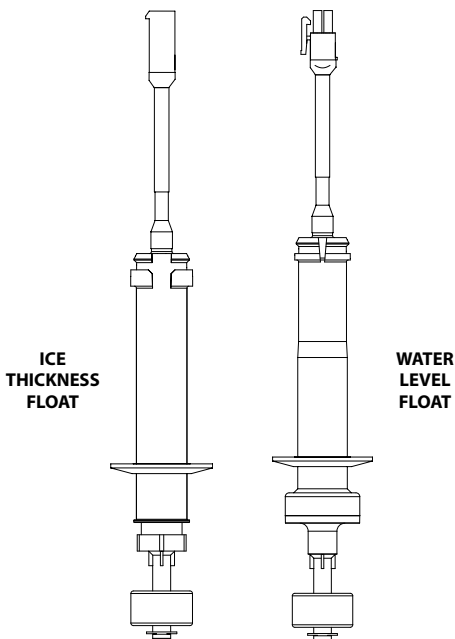

Compressor Electrical Diagnostics

The compressor does not start or will trip repeatedly on overload.

Check Resistance (Ohm) Values

NOTE: Compressor windings can have very low ohm values. Use a properly calibrated meter.

Perform the resistance test after the compressor cools. The compressor dome should be cool enough to touch (below 120°F/49°C) to ensure that the overload is closed and the resistance readings will be accurate.

Single Phase Compressors

1. Disconnect power and remove the wires from the compressor terminals.
2. The resistance values between C and S and between C and R, when added together should equal the resistance value between S and R.
3. If the overload is open, there will be a resistance reading between S and R, and open readings between C and S and between C and R. Allow the compressor to cool, then check the readings again.

Check Motor Windings to Ground

Check continuity between all three terminals and the compressor shell or copper refrigeration line. Scrape metal surface to get good contact. If continuity is present, the compressor windings are grounded and the compressor should be replaced.

To determine if the compressor is seized, check the amp draw while the compressor is trying to start.

Compressor Drawing Locked Rotor

The two likely causes of this are:

- Defective starting component
- Mechanically seized compressor

To determine which you have:

1. Install high and low side gauge.
2. Try to start the compressor.
3. Watch the pressures closely.
 - If the pressures do not move, the compressor is seized. Replace the compressor.
 - If the pressures move, the compressor is turning slowly and is not seized. Check the start components.

Compressor Drawing High Amps

The continuous amperage draw on start-up should not be near the maximum fuse size indicated on the serial tag.

The wiring must be correctly sized to minimize voltage drop at compressor start-up. The voltage when the compressor is trying to start must be within $\pm 10\%$ of the nameplate voltage.

Fan Cycle Control

Function

Cycles the fan motor on and off to maintain proper operating discharge pressure.

The fan cycle control closes on an increase, and opens on a decrease in discharge pressure.

Specifications

Model	Cut-In (Close)	Cut-Out (Open)
K0350 K0420	335 psig \pm 5	275 psig \pm 5
K0500 K0600 K1000	2310 kPa \pm 5	1896 kPa \pm 5
K1300 K1800	385 psig \pm 5 2654 kPa \pm 5	305 psig \pm 5 2103 kPa \pm 5

Check Procedure

Disconnect electrical power to the ice machine at the electrical service disconnect.

Verify fan motor windings are not open or grounded, and fan spins freely.

Connect manifold gauge to ice machine.

Hook voltmeter in parallel across the fan cycle control, leaving wires attached.

Reconnect electrical power to the ice machine and Cycle the toggle switch On.

Wait until water flows over the evaporator then refer to chart below.

System Pressure:	Reading Should Be:	Fan Should Be:
above cut-in	0 volts	running
below cut-out	line voltage	off

High Pressure Cutout (HPCO) Control

Function

Stops the ice machine if subjected to excessive high-side pressure.

The HPCO control is normally closed, and opens on a rise in discharge pressure.

Specifications

Cut-out: 600 psig ± 10 4137 kPa ± 10

Cut-in: 450 psig ± 10 3103 kPa ± 10

(Must be below 450 psig - 3103 kPa to reset).

Check Procedure

1. Move toggle switch to OFF.
2. Connect manifold gauge.
3. Hook voltmeter in parallel across the HPCO, leaving wires attached.
4. On water-cooled models, close the water service valve to the water condenser inlet. On self-contained air-cooled models, disconnect the fan motor.
5. Move toggle switch to ON.
6. No water or air flowing through the condenser will cause the HPCO control to open because of excessive pressure. Watch the pressure gauge and record the cut-out pressure.

Warning

If discharge pressure exceeds 600 psig - 4137 kPa and the HPCO control does not cut out, cycle the toggle switch Off to stop ice machine operation.

Replace the HPCO control if it:

- Will not reset (below 450 psig - 3103 kPa)
- Does not open at the specified cut-out point

Refrigeration Components

HEAD PRESSURE CONTROL VALVE

Manitowoc remote systems require head pressure control valves with special settings. Replace defective head pressure control valves only with "original" Manitowoc replacement parts.

Refrigerant Charge Verification

The correct amount of refrigerant (name plate charge) is required to operate correctly at all ambient conditions.

An ice machine with an overcharge or undercharge of refrigerant may function properly at higher ambient temperatures and fails at lower ambient temperatures.

Symptoms of incorrect refrigerant amount are:

- Works during the day and malfunctions at night, and/or fails whenever the outdoor temperature drops.
- A Safety limit is stored in control board memory.

Refrigerant loss and ambient temperature are directly related to each other. As the ambient temperature drops, more refrigerant is stored in the condenser.

When the refrigerant charge and ambient temperature create an undercharge of refrigerant in the freeze cycle, the receiver dip tube will lose it's liquid seal. Without liquid refrigerant to the TXV, the ice machine fails to make a full sheet of ice in 60 minutes and a safety limit #1 results.

NOTE: When a head pressure control valve is being replaced or refrigerant charge is suspected, verify the refrigerant charge is correct by recovering the refrigerant, weighing and comparing to the nameplate amount. Refer to Refrigerant Recovery/Evacuation for recovery procedures.

FREEZE CYCLE OPERATION ALL MODELS

The head pressure control valve is non adjustable.

At ambient temperatures of approximately 70°F (21°C) or above, refrigerant flows through the valve from the condenser to the receiver inlet. At temperatures below this (or at higher temperatures if it is raining), the head pressure control dome's nitrogen charge closes the condenser port and opens the bypass port from the compressor discharge line.

In this modulating mode, the valve maintains minimum head pressure by building up liquid in the condenser and bypassing discharge gas directly to the receiver.

HARVEST CYCLE OPERATION

Remote Condenser Models

The head pressure control cycles into full bypass due to the pressure drop when the harvest valve opens. Refrigerant flows from the compressor to the evaporator through the harvest valve and the head pressure valve is out of the circuit.

Diagnostics

FREEZE CYCLE - REMOTE CONDENSER

1. Determine if the coil is clean.
2. Determine the air temperature entering the condenser.
3. Determine if the head pressure is high or low in relationship to the outside temperature. (Refer to the proper "Cycle Times/24-Hour Ice Production/Refrigerant Pressure Charts").
4. Determine the temperature of the liquid line entering the receiver by feeling it. This line is normally warm; "body temperature."
5. Using the information gathered, refer to the chart.

NOTE: A head pressure control valve that will not bypass, will function properly with condenser air temperatures of approximately 70°F (21°C) or above. When the temperature drops below 70°F (21°C), the head pressure control valve fails to bypass and the ice machine malfunctions. Lower ambient conditions can be simulated by rinsing the condenser with cool water during the freeze cycle.

Condition	Probable Cause	Corrective Measure
Discharge Pressure - High Liquid Line Temperature - Hot	Valve stuck in bypass	Replace valve
Discharge Pressure - Low Liquid Line Temperature - Cold	Valve not bypassing	Replace valve
Discharge Pressure - Low Liquid Line Temperature - Hot	Ice Machine Low on Charge	Refrigerant Charge Verification

Harvest Cycle

REMOTE CONDENSER

The head pressure control cycles into full bypass due to the pressure drop when the harvest valve opens. Refrigerant flows from the compressor to the evaporator through the harvest valve and the head pressure valve is out of the circuit.

Undercharge Symptoms

- Safety limit #1 or Safety limit #2 in control board memory, a flashing triangle alert and after pressing left arrow Long Freeze or Long Harvest is displayed.
- Harvest cycle suction pressure is low.
- Harvest cycle discharge pressure is low.
- Liquid line entering receiver feels warm to hot in the freeze cycle.

Overcharge Symptoms

- Safety limit #2 in control board memory, a flashing triangle alert and after pressing left arrow Long Harvest is displayed.
- Harvest cycle discharge pressure is normal.
- Freeze cycle time, suction and discharge pressure are normal and the ice machine will not harvest. The sheet of ice cubes show little or no sign of melting when removed from the evaporator after the harvest cycle has been completed. (If the cubes are melted you have a release problem, clean the ice machine).

HARVEST PRESSURE REGULATING (HPR) SYSTEM REMOTE CONDENSER ONLY

GENERAL

The harvest pressure regulating (HPR) system includes:

- Harvest pressure regulating solenoid valve (HPR solenoid). This is an electrically operated valve which opens when energized, and closes when de-energized.
- Harvest pressure regulating valve (HPR valve). This is a pressure regulating valve which modulates open and closed, based on the refrigerant pressure at the outlet of the valve. The valve closes completely and stops refrigerant flow when the pressure at the outlet rises above the valve setting.

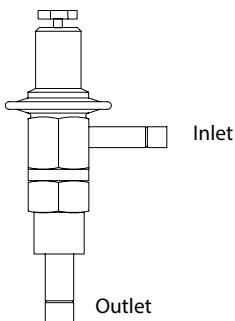

HPR VALVE

FREEZE CYCLE

The HPR system is not used during the freeze cycle. The HPR solenoid is closed (de-energized), preventing refrigerant flow into the HPR valve.

HARVEST CYCLE

During the harvest cycle, the check valve in the discharge line prevents refrigerant in the remote condenser and receiver from back feeding into the evaporator and condensing to liquid.

The HPR solenoid is opened (energized) during the harvest cycle, allowing refrigerant gas from the top of the receiver to flow into the HPR valve. The HPR valve modulates open and closed, raising the suction pressure high enough to sustain heat for the harvest cycle, without allowing refrigerant to condense to liquid in the evaporator.

In general, harvest cycle suction pressure rises, then stabilize. Exact pressures vary from model to model. Refer to cycle time/24 hour ice production and operational pressure charts.

HPR DIAGNOSTICS

Steps 1 through 5 can be quickly verified without attaching a manifold gauge set or thermometer.

All questions must have a yes answer to continue the diagnostic procedure.

1. Liquid line warm?
(Body temperature is normal)
If liquid line is cooler than body temperature, refer to head pressure control valve diagnostics.
2. Ice fill pattern normal?
Refer to "Ice Formation Pattern" if ice fill is not normal.

3. Freeze time normal?
(Refer to Cycle Times/Refrigerant Pressures/24 Hour Ice Production Charts).
 - A. Shorter freeze cycles?
Refer to head pressure control valve diagnostics.
 - B. Longer freeze cycles?
Refer to water system checklist, then refer to Refrigeration Diagnostic Procedures.
4. Harvest time is longer than normal and control board indicates safety limit #2?
(Refer to Cycle Times/Refrigerant Pressures/24 Hour Ice Production Charts).
5. Discharge line temperature is greater than 160°F at the end of the freeze cycle?
(Refer to Discharge Line Temperature Analysis)
6. Connect refrigeration manifold gauge set to the access valves on the front of the ice machine. Establish baseline by recording suction and discharge pressure and freeze & harvest cycle times. (Refer to "Freeze Cycle Refrigeration System Operational Analysis Tables" for data collection detail).
7. Freeze cycle Head Pressure is in the range indicated in the cycle time/24 hour ice production and operational pressure chart?
If the head pressure is low refer to head pressure control valve diagnostics.
8. Freeze cycle Suction Pressure normal?
Refer to analyzing suction pressure if suction pressure is high or low.
9. Harvest cycle suction and discharge pressures are lower than indicated in the cycle times/refrigerant pressures/24 hour ice production chart?
Replace Harvest Pressure Regulating solenoid

WATER REGULATING VALVE

Water-Cooled Models Only

FUNCTION

The water regulating valve maintains the freeze cycle discharge pressure.

CHECK PROCEDURE

1. Determine if the head pressure is high or low (refer to cycle time/24 hour ice production and operational pressure chart for the model you are servicing).
2. Verify the condenser water meets specifications.
3. Adjust valve to increase or decrease discharge pressure.
4. Determine the temperature of the liquid line entering the receiver by feeling it. This line is normally warm; body temperature.
5. Using the information gathered, refer to the list for diagnosis.

Problem (Freeze Cycle)

VALVE NOT MAINTAINING DISCHARGE PRESSURE.

- Valve incorrectly set, dirty or defective. Adjust, clean or replace valve.

DISCHARGE PRESSURE EXTREMELY HIGH; LIQUID LINE ENTERING RECEIVER FEELS HOT.

- Water regulating valve incorrectly set or not opening.

DISCHARGE PRESSURE LOW, LIQUID LINE ENTERING RECEIVER FEELS WARM TO HOT.

- Ice machine low on charge - Verify Total System Refrigerant Charge

Refrigerant Recovery/Evacuation

DEFINITIONS

Recover

To remove refrigerant, in any condition, from a system and store it in an external container, without necessarily testing or processing it in any way.

Recycle

To clean refrigerant for re-use by oil separation and single or multiple passes through devices, such as replaceable core filter-driers, which reduce moisture, acidity and particulate matter. This term usually applies to procedures implemented at the field job site or at a local service shop.

Reclaim

To reprocess refrigerant to new product specifications (see below) by means which may include distillation. A chemical analysis of the refrigerant is required after processing to be sure that product specifications are met. This term usually implies the use of processes and procedures available only at a reprocessing or manufacturing facility.

Chemical analysis is the key requirement in this definition. Regardless of the purity levels reached by a reprocessing method, refrigerant is not considered "reclaimed" unless it has been chemically analyzed and meets ARI Standard 700 (latest edition).

New Product Specifications

This means ARI Standard 700 (latest edition). Chemical analysis is required to assure that this standard is met.

REFRIGERANT RE-USE POLICY

Koolaire recognizes and supports the need for proper handling, re-use, and disposal of refrigerants. Koolaire service procedures require recapturing refrigerants, not venting them to the atmosphere.

It is not necessary, in or out of warranty, to reduce or compromise the quality and reliability of your customers' products to achieve this.

Important

Koolaire assumes no responsibility for use of contaminated refrigerant. Damage resulting from the use of contaminated, recovered, or recycled refrigerant is the sole responsibility of the servicing company.

Koolaire approves the use of:

1. New Refrigerant
 - Must be of original nameplate type.
2. Reclaimed Refrigerant
 - Must be of original nameplate type.
 - Must meet ARI Standard 700 (latest edition) specifications.
3. Recovered or Recycled Refrigerant
 - Must be recovered or recycled in accordance with current local, state and federal laws.
 - Must be recovered from and re-used in the same Koolaire product. Re-use of recovered or recycled refrigerant from other products is not approved.
 - Recycling equipment must be certified to ARI Standard 740 (latest edition) and be maintained to consistently meet this standard.

4. Recovered refrigerant must come from a “contaminant-free” system. To decide whether the system is contaminant free, consider:
 - Type(s) of previous failure(s)
 - Whether the system was cleaned, evacuated and recharged properly following failure(s)
 - Whether the system has been contaminated by this failure
 - Compressor motor burnouts and improper past service prevent refrigerant re-use.
 - Refer to “Remote Condenser Model Procedure” on page 110 to test for contamination.
5. “Substitute” or “Alternative” Refrigerant
 - Must use only Koolaire-approved alternative refrigerants.
 - Must follow Koolaire-published conversion procedures.

RECOVERY AND RECHARGING PROCEDURES

Do not purge refrigerant to the atmosphere. Capture refrigerant using recovery equipment. Follow the manufacturer's recommendations.

Important

Koolaire assumes no responsibility for the use of contaminated refrigerant. Damage resulting from the use of contaminated refrigerant is the sole responsibility of the servicing company.

Important

Replace the liquid line drier before evacuating and recharging. Use only a Koolaire (O.E.M.) liquid line filter drier to prevent voiding the warranty.

CONNECTIONS

1. Suction side of the compressor through the suction service valve.
2. Discharge side of the compressor through the discharge service valve.

SELF-CONTAINED RECOVERY/EVACUATION

1. Cycle the toggle switch Off.
2. Install manifold gauge set and recovery unit or two-stage vacuum pump.
3. Perform recovery or evacuation:
 - A. Recovery: Operate the recovery unit as directed by the manufacturer's instructions.
 - B. Evacuation prior to recharging: Pull the system down to 500 microns. Then, allow the pump to run for an additional half hour. Turn off the pump and perform a standing vacuum leak check.

CHARGING PROCEDURES

Important

The charge is critical on all Koolaire machines. Use a scale or a charging cylinder to ensure the proper charge is installed.

1. Cycle the toggle switch Off.
2. Close the vacuum pump valve, the low side manifold gauge valve.
3. Open the high side manifold gauge valve.
4. Open the charging cylinder and add the proper refrigerant charge (shown on nameplate) through the discharge service valve.
5. Let the system "settle" for 2 to 3 minutes.
6. Cycle the toggle switch On.
7. Close the high side on the manifold gauge set.

NOTE: Manifold gauge set must be removed properly to ensure that no refrigerant contamination or loss occurs.

8. Make sure that all of the vapor in the charging hoses is drawn into the ice machine before disconnecting the charging hoses.
 - A. Run the ice machine in freeze cycle.
 - B. Open the high and low side valves on the manifold gauge set. Any refrigerant in the lines will be pulled into the low side of the system.
 - C. Disconnect the low loss fitting while the ice machine is in the freeze cycle and install the caps.
 - D. Check for leaks using an electronic leak detector.

REMOTE CONDENSER MODEL PROCEDURE

Refrigerant Recovery/Evacuation

Do not purge refrigerant to the atmosphere. Capture refrigerant using recovery equipment. Follow the manufacturer's recommendations.

Important

Koolaire assumes no responsibility for the use of contaminated refrigerant. Damage resulting from the use of contaminated refrigerant is the sole responsibility of the servicing company.

Important

Replace the liquid line drier after recovering the refrigerant and before evacuating and recharging. Use only a Manitowoc (O.E.M.) liquid line filter drier to prevent voiding the warranty.

Important

Recovery/evacuation of a remote system requires connections at four points for complete system evacuation.

MAKE THESE CONNECTIONS:

- Suction side of the compressor through the suction service valve.
- Discharge side of the compressor through the discharge service valve.
- Receiver outlet service valve, which evacuates the area between the check valve in the liquid line and the pump down solenoid.

- Access valve on the discharge line quick-connect fitting, located on the outside of the compressor/evaporator compartment. This connection evacuates the condenser. Without it, the magnetic check valves would close when the pressure drops during evacuation, preventing complete evacuation of the condenser.

NOTE: Koolaire recommends using an access valve core removal and installation tool on the discharge line quick-connect fitting. This permits access valve core removal. This allows for faster evacuation and charging, without removing the manifold gauge hose.

REMOTE CONDENSER RECOVERY/EVACUATION

1. Press the power button to stop the ice machine.
2. Install manifold gauge set, scale and recovery unit or two-stage vacuum pump.
3. Open high and low side on the manifold gauge set.
4. Perform recovery or evacuation:
 - A. Recovery: Operate the recovery unit as directed by the manufacturer's instructions.
 - B. Evacuation prior to recharging: Pull the system down to 500 microns. Then, allow the pump to run for an additional hour. Turn off the pump and perform a standing vacuum leak check.

NOTE: Check for leaks with an electronic leak detector after charging the ice machine.

5. Follow the Remote Charging Procedures.

REMOTE CHARGING PROCEDURES

1. Close the vacuum pump valve and the low side manifold gauge valve.
2. Open the refrigerant cylinder and add the proper refrigerant charge (shown on nameplate) into the system high side (receiver outlet valve and discharge lines quick-connect fitting).
3. If the high side does not take the entire charge, close the high side on the manifold gauge set and start the ice machine. Add the remaining charge through the low side (in vapor form) until the machine is fully charged.

NOTE: If an access valve core removal and installation tool is used on any of the access valves, reinstall the cores before disconnecting the access tool and hose.

4. Open the high and low side valves on the manifold gauge set. Any refrigerant in the lines will be pulled into the low side of the system.
5. Allow the pressures to equalize while the ice machine is in the freeze cycle.
6. Remove the low side hose from the access valve and install the caps.

System Contamination Cleanup

This section describes the basic requirements for restoring contaminated systems to reliable service.

Important

Koolaire assumes no responsibility for the use of contaminated refrigerant. Damage resulting from the use of contaminated refrigerant is the sole responsibility of the servicing company.

DETERMINING SEVERITY OF CONTAMINATION

System contamination is generally caused by either moisture or residue from compressor burnout entering the refrigeration system.

Inspection of the refrigerant usually provides the first indication of system contamination. Obvious moisture or an acid odor in the refrigerant indicates contamination.

If either condition is found, or if contamination is suspected, use a Total Test Kit from Totaline or a similar diagnostic tool. These devices sample refrigerant, eliminating the need to take an oil sample. Follow the manufacturer's directions.

If a refrigerant test kit indicates harmful levels of contamination, or if a test kit is not available, inspect the compressor oil.

1. Remove the refrigerant charge from the ice machine.
2. Remove the compressor from the system.
3. Check the odor and appearance of the oil.
4. Inspect open suction and discharge lines at the compressor for burnout deposits.
5. If no signs of contamination are present, perform an acid oil test to determine the type of cleanup required.

Contamination/Cleanup Chart	
Symptoms/Findings	Required Cleanup Procedure
No symptoms or suspicion of contamination	Normal evacuation/recharging procedure
Moisture/Air Contamination symptoms Refrigeration system open to atmosphere for longer than 15 minutes Refrigeration test kit and/or acid oil test shows contamination No burnout deposits in open compressor lines	Mild contamination cleanup procedure
Mild Compressor Burnout symptoms Oil appears clean but smells acrid Refrigeration test kit or acid oil test shows harmful acid content No burnout deposits in open compressor lines	Mild contamination cleanup procedure
Severe Compressor Burnout symptoms Oil is discolored, acidic, and smells acrid Burnout deposits found in the compressor, lines, and other components	Severe contamination cleanup procedure

MILD SYSTEM CONTAMINATION CLEANUP PROCEDURE

1. Replace any failed components.
2. If the compressor is good, change the oil.
3. Replace the liquid line drier.

NOTE: If the contamination is from moisture, use heat lamps during evacuation. Position them at the compressor, condenser and evaporator prior to evacuation. Do not position heat lamps too close to plastic components, or they may melt or warp.

4. Follow the normal evacuation procedure, except replace the evacuation step with the following:
 - A. Pull vacuum to 1000 microns. Break the vacuum with dry nitrogen and sweep the system. Pressurize to a minimum of 5 psig.
 - B. Pull vacuum to 500 microns. Break the vacuum with dry nitrogen and sweep the system. Pressurize to a minimum of 5 psig.
 - C. Change the vacuum pump oil.
 - D. Pull vacuum to 500 microns. Run the vacuum pump for 1/2 hour on self-contained models, 1 hour on remotes.

NOTE: You may perform a pressure test as a preliminary leak check. You should use an electronic leak detector after system charging to be sure there are no leaks.

5. Charge the system with the proper refrigerant to the nameplate charge.
6. Operate the ice machine.

SEVERE SYSTEM CONTAMINATION CLEANUP PROCEDURE

1. Remove the refrigerant charge.
2. Remove the compressor.
3. Disassemble the harvest solenoid valve. If burnout deposits are found inside the valve, install a rebuild kit, and replace the TXV and head pressure control valve.
4. Wipe away any burnout deposits from suction and discharge lines at compressor.
5. Sweep through the open system with dry nitrogen.
6. Install a new compressor and new start components.
7. Install suction line filter-drier in front of compressor.
8. Install a new liquid line drier.
9. Follow the normal evacuation procedure, except replace the evacuation step with the following:
 - A. Pull vacuum to 1000 microns. Break the vacuum with dry nitrogen and sweep the system. Pressurize to a minimum of 5 psig.
 - B. Change the vacuum pump oil.
 - C. Pull vacuum to 500 microns. Break the vacuum with dry nitrogen and sweep the system. Pressurize to a minimum of 5 psig.
 - D. Change the vacuum pump oil.
 - E. Pull vacuum to 500 microns. Run the vacuum pump for 1 additional hour.
10. Charge the system with the proper refrigerant to the nameplate charge.
11. Operate the ice machine for one hour. Then, check the pressure drop across the suction line filter-drier.
 - A. If the pressure drop is less than 2 psig, the filter-drier should be adequate for complete cleanup.
 - B. If the pressure drop exceeds 2 psig, change the suction line filter-drier and the liquid line drier. Repeat until the pressure drop is acceptable.
12. Operate the ice machine for 48 – 72 hours. Replace the suction line and liquid line drier if necessary.
13. Follow normal evacuation procedures.

REPLACING PRESSURE CONTROLS WITHOUT REMOVING REFRIGERANT CHARGE

This procedure reduces repair time and cost. Use it when any of the following components require replacement, and the refrigeration system is operational and leak-free.

- Fan cycle control
- High pressure cut-out control
- High side access valve
- Low side access valve

Important

This is a required in-warranty repair procedure.

1. Disconnect power to the ice machine.
2. Follow all manufacturers' instructions supplied with the pinch-off tool. Position the pinch-off tool around the tubing as far from the pressure control as feasible. (See the figure on next page.) Clamp down on the tubing until the pinch-off is complete.

Warning

Do not unsolder a defective component. Cut it out of the system. Do not remove the pinch-off tool until the new component is securely in place.

3. Cut the tubing of the defective component with a small tubing cutter.
4. Solder the replacement component in place. Allow the solder joint to cool.
5. Remove the pinch-off tool.
6. Re-round the tubing. Position the flattened tubing in the proper hole in the pinch off tool. Tighten the wing nuts until the block is tight and the tubing is rounded.

NOTE: The pressure controls will operate normally once the tubing is re-rounded. Tubing may not re-round 100%.

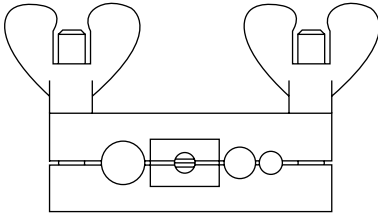

FIG. A - "PINCHING OFF" TUBING

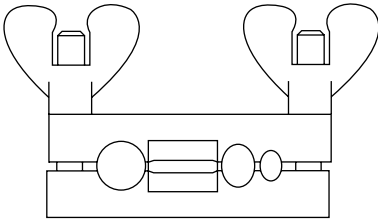

FIG. B - RE-ROUNDING TUBING

SV1406

Using Pinch Off Tool

Refrigerant Amount

NOTE: All models charged with R410A refrigerant.

Model	Air-Cooled	Water-Cooled	Remote	51' to 100' Line sets*
K0250 60Hz	15 oz 425 g	N/A	N/A	N/A
K0250 50Hz	17 oz 482 g	N/A	N/A	N/A
K0350 60Hz	18 oz 510 g	14 oz 397 g	N/A	N/A
K0350 50Hz	21 oz 595 g	14 oz 397 g	N/A	N/A
K0420 60Hz and 50Hz	16 oz 454 g	14 oz 397 g	N/A	N/A
K0500 60Hz and 50Hz	18 oz 510 g	14 oz 397 g	N/A	N/A
K0600 60Hz and 50Hz	24 oz 680 g	18 oz 510 g	N/A	N/A
K1000 60hz	28 oz 794 g	24 oz 680 g	7 lbs 8 oz 3.4 kg	2 lbs 907 g
K1000 50hz	44 oz 1247 g	24 oz 680 g	7 lbs 8 oz 3.4 kg	2 lbs 907 g
K1350 60Hz and 50Hz	42 oz 1191 g	24 oz 680 g	11 lbs 8 oz 5.2 kg	2 lbs 907 g
K1800 60Hz and 50Hz	46 oz 1304 g	N/A	12 lbs 5.4 kg	2 lbs 907 g
* Additional amount of refrigerant to be added for remote condenser with line sets that are 51' to 100' in length				

THIS PAGE INTENTIONALLY LEFT BLANK

Charts

Cycle Times, 24 Hr. Ice Production and Refrigerant Pressure Charts

These charts are used as guidelines to verify correct ice machine operation.

Accurate collection of data is essential to obtain the correct diagnosis.

- Production and cycle times are for dice cube - Half dice cube cycle times can be 1-2 minutes faster depending on model and ambient temperature.
- Ice production checks that are within 10% of the chart are considered normal. This is due to variances in water and air temperature. Actual temperatures will seldom match the chart exactly.
- Refer to "Operational Analysis Chart" for the list of data that must be collected for refrigeration diagnostics.
- Zero out manifold gauge set before obtaining pressure readings to avoid mis-diagnosis.
- Discharge and suction pressure are highest at the beginning of the cycle. Suction pressure will drop throughout the cycle. Verify the pressures are within the range indicated.
- Record beginning of freeze cycle suction pressure one minute after the water pump energizes.

K0250A SELF-CONTAINED AIR-COOLED

NOTE: These characteristics may vary depending on operating conditions.

Cycle Times

Freeze Time + Harvest Time = Total Cycle Time

Air Temp. Entering Condenser °F/°C	Freeze Time			Harvest Time
	Water Temperature °F/°C			
	50/10	70/21	90/32	
70/21	9.3-11.5	10.8-12.9	12.3-14.6	1.0-2.5
80/27	10.6-12.6	12.3-14.6	13.5-16.0	
90/32	11.8-14.0	13.9-16.4	15.0-17.7	
100/38	13.2-15.7	14.6-17.3	16.2-19.2	
110/43	15.0-17.7	15.8-18.7	17.7-20.9	

Times in minutes

24 Hour Ice Production

Air Temp. Entering Condenser °F/°C	Water Temperature °F/°C		
	50/10	70/21	90/32
70/21	310	280	250
80/27	285	250	230
90/32	260	225	210
100/38	235	215	195
110/43	210	200	180

Based on average ice slab weight of 3.40 – 3.90 lb (1.54 – 1.79 kg)
230/50/1 production is approximately 12% lower than 230/60/1.

Operating Pressures

Air Temp. Entering Condenser °F/°C	Freeze Cycle		Harvest Cycle	
	Discharge Pressure PSIG	Suction Pressure PSIG	Discharge Pressure PSIG	Suction Pressure PSIG
50/10	300-335	70-38	160-180	150-175
70/21	310-340	75-40	180-200	150-175
80/27	315-360	80-42	185-210	150-175
90/32	320-375	90-44	190-215	150-175
100/38	420-510	100-49	300-330	200-250
110/43	450-540	120-52	355-370	270-290

Suction pressure drops gradually throughout the freeze cycle

K0350A SELF-CONTAINED AIR-COOLED

NOTE: These characteristics may vary depending on operating conditions.

Cycle Times

Freeze Time + Harvest Time = Total Cycle Time

Air Temp. Entering Condenser °F/°C	Freeze Time			Harvest Time
	Water Temperature °F/°C			
	50/10	70/21	90/32	
70/21	11.6-13.5	12.7-14.8	14.0-16.3	1.0-2.5
80/27	12.5-14.5	14.0-16.3	15.1-17.5	
90/32	13.6-15.8	14.8-17.2	15.7-18.2	
100/38	14.8-17.2	15.4-17.9	16.6-19.3	
110/43	15.7-18.2	16.3-18.9	17.0-19.7	

Times in minutes

24 Hour Ice Production

Air Temp. Entering Condenser °F/°C	Water Temperature °F/°C		
	50/10	70/21	90/32
70/21	375	345	315
80/27	350	315	295
90/32	325	300	285
100/38	300	290	270
110/43	285	275	265

Based on average ice slab weight of 3.40 – 3.90 lb (1.54 – 1.79 kg) 230/50/1 production is approximately 12% lower than 230/60/1.

Operating Pressures

Air Temp. Entering Condenser °F/°C	Freeze Cycle		Harvest Cycle	
	Discharge Pressure PSIG	Suction Pressure PSIG	Discharge Pressure PSIG	Suction Pressure PSIG
50/10	260-320	55-32	130-200	90-140
70/21	275-340	60-33	150-200	100-140
80/27	285-395	65-34	170-230	105-165
90/32	335-410	70-35	190-250	110-175
100/38	400-500	80-40	280-340	160-220
110/43	450-520	85-42	320-360	190-235

Suction pressure drops gradually throughout the freeze cycle

K0350W SELF-CONTAINED WATER-COOLED

NOTE: These characteristics may vary depending on operating conditions.

Cycle Times

Freeze Time + Harvest Time = Total Cycle Time

Air Temp. Around Ice Machine °F/°C	Freeze Time			Harvest Time
	Water Temperature °F/°C			
	50/10	70/21	90/32	
70/21	11.4-13.3	12.3-14.3	13.1-15.3	1.0-2.5
80/27	11.6-13.5	12.5-14.5	13.3-15.5	
90/32	11.7-13.7	14.6-16.1	13.6-15.8	
100/38	11.9-13.9	12.9-15.0	13.8-16.1	
110/43	12.1-14.1	13.8-16.1	14.0-16.3	

Times in minutes

24 Hour Ice Production

Air Temp. Around Ice Machine °F/°C	Water Temperature °F/°C		
	50/10	70/21	90/32
70/21	380	355	335
80/27	375	350	330
90/32	370	340	325
100/38	365	330	320
110/43	360	320	315

Based on average ice slab weight of 3.40 – 3.90 lb (1.54 – 1.79 kg)
Water regulating valve set to maintain 320 PSIG discharge
pressure

Condenser Water usage per 100 lbs ice = 170 gal (45 kg = 644 L)
230/50/1 production is approximately 12% lower than 230/60/1.

Operating Pressures

Air Temp. Around Ice Machine °F/°C	Freeze Cycle		Harvest Cycle	
	Discharge Pressure PSIG	Suction Pressure PSIG	Discharge Pressure PSIG	Suction Pressure PSIG
50/10	315-330	60-34	150-210	110-150
70/21	315-330	60-34	150-210	110-150
80/27	315-330	60-34	150-210	110-150
90/32	315-330	60-34	150-210	110-150
100/38	315-335	60-34	150-210	110-150
110/43	315-340	65-36	150-210	110-150

Suction pressure drops gradually throughout the freeze cycle

K0420A SELF-CONTAINED AIR-COOLED

NOTE: These characteristics may vary depending on operating conditions.

Cycle Times

Freeze Time + Harvest Time = Total Cycle Time

Air Temp. Entering Condenser °F/°C	Freeze Time			Harvest Time
	Water Temperature °F/°C			
	50/10	70/21	90/32	
70/21	11.7-13.7	12.5-14.5	13.6-15.8	1.0-2.5
80/27	12.9-15.0	13.8-16.1	15.4-17.9	
90/32	14.0-16.3	14.6-16.9	16.6-19.3	
100/38	15.7-18.2	17.0-19.7	18.1-21.0	
110/43	17.7-20.5	18.9-21.9	20.3-23.5	

Times in minutes

24 Hour Ice Production

Air Temp. Entering Condenser °F/°C	Water Temperature °F/°C		
	50/10	70/21	90/32
70/21	370	350	325
80/27	340	320	290
90/32	315	305	270
100/38	285	265	250
110/43	255	240	225

Based on average ice slab weight of 3.40 – 3.90 lb (1.54 – 1.79 kg) 230/50/1 production is approximately 12% lower than 230/60/1.

Operating Pressures

Air Temp. Entering Condenser °F/°C	Freeze Cycle		Harvest Cycle	
	Discharge Pressure PSIG	Suction Pressure PSIG	Discharge Pressure PSIG	Suction Pressure PSIG
50/10	275-360	60-31	180-220	130-160
70/21	290-380	65-32	200-220	140-160
80/27	300-390	65-33	215-235	150-170
90/32	330-400	70-34	235-245	160-180
100/38	400-500	80-34	355-370	240-270
110/43	430-520	95-34	370-375	255-275

Suction pressure drops gradually throughout the freeze cycle

K0420W SELF-CONTAINED WATER-COOLED

NOTE: These characteristics may vary depending on operating conditions.

Cycle Times

Freeze Time + Harvest Time = Total Cycle Time

Air Temp. Around Ice Machine °F/°C	Freeze Time			Harvest Time
	Water Temperature °F/°C			
	50/10	70/21	90/32	
70/21	11.7-13.7	11.2-15.2	12.7-13.5	1.0-2.5
80/27	13.1-14.0	14.6-15.5	12.9-17.7	
90/32	13.3-14.2	11.7-15.8	13.1-18.1	
100/38	13.1-14.9	15.1-17.5	17.3-18.4	
110/43	14.0-15.0	15.4-16.4	17.7-18.8	

Times in minutes

24 Hour Ice Production

Air Temp. Around Ice Machine °F/°C	Water Temperature °F/°C		
	50/10	70/21	90/32
70/21	370	310	275
80/27	335	305	270
90/32	330	300	265
100/38	320	295	260
110/43	315	290	255

Based on average ice slab weight of 3.40 – 3.90 lb (1.54 – 1.79 kg)
Water regulating valve set to maintain 320 PSIG discharge pressure

Condenser Water usage per 100 lbs ice = 170 gal (45 kg = 644 L)
230/50/1 production is approximately 12% lower than 230/60/1.

Operating Pressures

Air Temp. Around Ice Machine °F/°C	Freeze Cycle		Harvest Cycle	
	Discharge Pressure PSIG	Suction Pressure PSIG	Discharge Pressure PSIG	Suction Pressure PSIG
50/10	325-335	70-31	155-230	110-165
70/21	325-335	70-31	155-235	110-170
80/27	325-335	70-31	160-240	110-170
90/32	325-335	75-31	160-245	110-175
100/38	325-345	80-31	160-245	115-180
110/43	325-350	80-31	160-245	115-180

Suction pressure drops gradually throughout the freeze cycle

K0500A SELF-CONTAINED AIR-COOLED

NOTE: These characteristics may vary depending on operating conditions.

Cycle Times

Freeze Time + Harvest Time = Total Cycle Time

Air Temp. Entering Condenser °F/°C	Freeze Time			Harvest Time
	Water Temperature °F/°C			
	50/10	70/21	90/32	
70/21	11.9-13.6	14.1-16.1	15.7-17.9	1.0-2.5
80/27	13.6-15.5	15.1-17.2	16.6-19.0	
90/32	14.9-17.0	15.5-17.7	17.7-20.2	
100/38	16.6-19.0	18.3-20.9	20.2-23.1	
110/43	18.9-21.5	19.5-22.3	20.6-23.5	

Times in minutes

24 Hour Ice Production

Air Temp. Entering Condenser °F/°C	Water Temperature °F/°C		
	50/10	70/21	90/32
70/21	495	425	385
80/27	440	400	365
90/32	405	390	345
100/38	365	335	305
110/43	325	315	300

Based on average ice slab weight of 4.6 – 5.2 lb (2.1 – 2.36 kg)
230/50/1 production is approximately 12% lower than 230/60/1.

Operating Pressures

Air Temp. Entering Condenser °F/°C	Freeze Cycle		Harvest Cycle	
	Discharge Pressure PSIG	Suction Pressure PSIG	Discharge Pressure PSIG	Suction Pressure PSIG
50/10	260-325	60-36	140-175	100-120
70/21	270-340	65-37	150-185	105-130
80/27	275-380	65-37	165-200	110-150
90/32	340-400	75-38	190-220	130-160
100/38	380-500	80-42	280-320	180-235
110/43	440-520	80-44	290-330	185-240

Suction pressure drops gradually throughout the freeze cycle

K0500W SELF-CONTAINED WATER-COOLED

NOTE: These characteristics may vary depending on operating conditions.

Cycle Times

Freeze Time + Harvest Time = Total Cycle Time

Air Temp. Around Ice Machine °F/°C	Freeze Time			Harvest Time
	Water Temperature °F/°C			
	50/10	70/21	90/32	
70/21	10.7-13.7	13.6-15.5	15.7-17.7	1.0-2.5
80/27	12.0-13.8	13.7-15.7	15.5-17.9	
90/32	12.4-14.3	13.9-15.9	16.4-18.7	
100/38	12.7-14.6	14.5-16.5	16.6-19.0	
110/43	13.1-15.0	14.7-16.8	16.9-19.3	

Times in minutes

24 Hour Ice Production

Air Temp. Around Ice Machine °F/°C	Water Temperature °F/°C		
	50/10	70/21	90/32
70/21	545	440	390
80/27	490	435	385
90/32	475	430	370
100/38	465	415	365
110/43	455	410	360

Based on average ice slab weight of 4.6 – 5.2 lb (2.1– 2.4 kg)
 Water regulating valve set to maintain 330 PSI discharge pressure
 Condenser Water usage per 100 lbs ice = 160 gal (45 kg = 606 L)
 230/50/1 production is approximately 12% lower than 230/60/1.

Operating Pressures

Air Temp. Around Ice Machine °F/°C	Freeze Cycle		Harvest Cycle	
	Discharge Pressure PSIG	Suction Pressure PSIG	Discharge Pressure PSIG	Suction Pressure PSIG
50/10	325-335	70-38	145-175	105-130
70/21	325-335	70-39	150-180	110-135
80/27	325-335	75-39	150-185	110-135
90/32	325-340	80-39	150-190	110-135
100/38	325-340	80-39	150-190	110-135
110/43	325-345	80-39	150-190	110-135

Suction pressure drops gradually throughout the freeze cycle

K0600A SELF-CONTAINED AIR-COOLED

NOTE: These characteristics may vary depending on operating conditions.

Cycle Times

Freeze Time + Harvest Time = Total Cycle Time

Air Temp. Entering Condenser °F/°C	Freeze Time			Harvest Time
	Water Temperature °F/°C			
	50/10	70/21	90/32	
70/21	8.5-11.0	11.5-13.2	12.4-14.3	1.0-2.5
80/27	10.5-12.1	12.0-13.8	12.7-14.6	
90/32	11.7-13.5	12.2-13.9	13.9-15.9	
100/38	12.9-14.8	13.2-15.1	14.1-16.1	
110/43	13.6-15.5	14.1-16.1	14.5-16.5	

Times in minutes

24 Hour Ice Production

Air Temp. Entering Condenser °F/°C	Water Temperature °F/°C		
	50/10	70/21	90/32
70/21	600	510	475
80/27	550	490	465
90/32	500	485	430
100/38	460	450	425
110/43	440	425	415

Based on average ice slab weight of 4.6 – 5.2 lb (2.1 – 2.4 kg)
230/50/1 production is approximately 12% lower than 230/60/1.

Operating Pressures

Air Temp. Entering Condenser °F/°C	Freeze Cycle		Harvest Cycle	
	Discharge Pressure PSIG	Suction Pressure PSIG	Discharge Pressure PSIG	Suction Pressure PSIG
50/10	260-325	60-28	140-175	90-120
70/21	275-350	65-30	165-200	100-130
80/27	275-380	70-31	165-210	105-150
90/32	350-415	75-35	310-370	170-215
100/38	380-520	80-36	310-375	170-235
110/43	440-540	80-36	310-375	170-225

Suction pressure drops gradually throughout the freeze cycle

K0600W SELF-CONTAINED WATER-COOLED

NOTE: These characteristics may vary depending on operating conditions.

Cycle Times

Freeze Time + Harvest Time = Total Cycle Time

Air Temp. Around Ice Machine °F/°C	Freeze Time			Harvest Time
	Water Temperature °F/°C			
	50/10	70/21	90/32	
70/21	9.5-11.0	10.9-12.5	11.5-13.2	1.0-2.5
80/27	9.8-11.3	11.1-12.8	11.7-13.5	
90/32	10.9-12.5	11.2-12.9	12.7-14.6	
100/38	11.9-13.6	12.2-13.9	12.9-14.8	
110/43	12.4-14.3	12.9-14.8	13.2-15.1	

Times in minutes

24 Hour Ice Production

Air Temp. Around Ice Machine °F/°C	Water Temperature °F/°C		
	50/10	70/21	90/32
70/21	600	535	510
80/27	585	525	500
90/32	535	520	465
100/38	495	485	460
110/43	475	460	450

Based on average ice slab weight of 4.6 – 5.2 lb (2.1 – 2.4 kg)
Water regulating valve set to maintain 320 PSI discharge pressure
Condenser Water usage per 100 lbs ice = 170 gal (45 kg = 644 L)
230/50/1 production is approximately 12% lower than 230/60/1.

Operating Pressures

Air Temp. Around Ice Machine °F/°C	Freeze Cycle		Harvest Cycle	
	Discharge Pressure PSIG	Suction Pressure PSIG	Discharge Pressure PSIG	Suction Pressure PSIG
50/10	315-325	55-31	160-210	100-135
70/21	315-325	55-32	180-225	100-140
80/27	315-325	60-32	180-230	105-140
90/32	315-325	65-32	180-230	105-140
100/38	315-325	65-32	180-230	105-140
110/43	315-325	65-32	180-230	105-140

Suction pressure drops gradually throughout the freeze cycle

K1000A SELF-CONTAINED AIR-COOLED

NOTE: These characteristics may vary depending on operating conditions.

Cycle Times

Freeze Time + Harvest Time = Total Cycle Time

Air Temp. Entering Condenser °F/°C	Freeze Time			Harvest Time
	Water Temperature °F/°C			
	50/10	70/21	90/32	
70/21	8.5-10.1	9.9-11.7	11.6-12.6	1.0-2.5
80/27	9.4-11.1	10.2-12.1	10.9-12.9	
90/32	10.2-12.1	11.0-13.0	12.0-14.2	
100/38	11.1-13.1	12.6-14.8	13.1-15.5	
110/43	12.1-14.3	13.0-15.4	13.9-16.4	

Times in minutes

24 Hour Ice Production

Air Temp. Entering Condenser °F/°C	Water Temperature °F/°C		
	50/10	70/21	90/32
70/21	895	785	735
80/27	820	765	720
90/32	765	715	660
100/38	710	635	610
110/43	655	615	580

Based on average ice slab weight of 6.2 – 7.2 lb (2.8 – 3.3 kg)
230/50/1 production is approximately 12% lower than 230/60/1.

Operating Pressures

Air Temp. Entering Condenser °F/°C	Freeze Cycle		Harvest Cycle	
	Discharge Pressure PSIG	Suction Pressure PSIG	Discharge Pressure PSIG	Suction Pressure PSIG
50/10	280-375	60-28	140-200	100-140
70/21	300-390	65-28	145-200	105-140
80/27	320-400	70-32	150-205	105-150
90/32	350-415	75-33	160-210	110-150
100/38	450-520	80-37	170-240	115-155
110/43	440-540	85-39	200-250	125-160

Suction pressure drops gradually throughout the freeze cycle

K1000W SELF-CONTAINED WATER-COOLED

NOTE: These characteristics may vary depending on operating conditions.

Cycle Times

Freeze Time + Harvest Time = Total Cycle Time

Air Temp. Around Ice Machine °F/°C	Freeze Time			Harvest Time
	Water Temperature °F/°C			
	50/10	70/21	90/32	
70/21	8.3-9.8	8.8-10.4	9.7-11.5	1.0-2.5
80/27	9.0-10.7	9.7-11.5	10.8-12.8	
90/32	9.9-11.8	10.7-12.7	11.0-13.0	
100/38	10.2-12.1	11.1-13.1	11.4-13.5	
110/43	10.8-12.8	11.3-13.4	11.8-14.0	

Times in minutes

24 Hour Ice Production

Air Temp. Around Ice Machine °F/°C	Water Temperature °F/°C		
	50/10	70/21	90/32
70/21	915	870	800
80/27	850	800	725
90/32	780	730	715
100/38	765	710	690
110/43	725	695	670

Based on average ice slab weight of 6.2 – 7.2 lb (2.8 – 3.3 kg)
Water regulating valve set to maintain 320 PSI discharge pressure.

Condenser Water usage per 100 lbs ice = 180 gal (45 kg = 681 L)
230/50/1 production is approximately 12% lower than 230/60/1.

Operating Pressures

Air Temp. Around Ice Machine °F/°C	Freeze Cycle		Harvest Cycle	
	Discharge Pressure PSIG	Suction Pressure PSIG	Discharge Pressure PSIG	Suction Pressure PSIG
50/10	295-310	65-30	140-220	100-155
70/21	295-310	65-30	140-220	100-155
80/27	295-310	65-32	145-225	100-160
90/32	295-310	65-32	150-225	105-160
100/38	300-330	68-33	150-230	105-165
110/43	310-345	70-34	150-235	105-165

Suction pressure drops gradually throughout the freeze cycle

K1000N REMOTE AIR-COOLED

NOTE: These characteristics may vary depending on operating conditions.

Cycle Times

Freeze Time + Harvest Time = Total Cycle Time

Air Temp. Entering Condenser °F/°C	Freeze Time			Harvest Time
	Water Temperature °F/°C			
	50/10	70/21	90/32	
70/21	8.2-9.7	8.5-10.1	9.4-11.1	1.0-2.5
80/27	9.1-10.8	9.9-11.7	10.2-12.1	
90/32	9.7-11.5	10.8-12.5	11.3-13.3	
100/38	10.6-12.5	11.4-13.5	12.2-14.5	
110/43	12.0-14.2	12.5-14.7	13.4-15.8	

Times in minutes

24 Hour Ice Production

Air Temp. Entering Condenser °F/°C	Water Temperature °F/°C		
	50/10	70/21	90/32
70/21	925	890	820
80/27	845	785	760
90/32	800	725	700
100/38	740	690	650
110/43	660	640	600

Based on average ice slab weight of 6.2 – 7.2 lb (2.8 – 3.3 kg)
230/50/1 production is approximately 12% lower than 230/60/1.

Operating Pressures

Air Temp. Entering Condenser °F/°C	Freeze Cycle		Harvest Cycle	
	Discharge Pressure PSIG	Suction Pressure PSIG	Discharge Pressure PSIG	Suction Pressure PSIG
50/10	300-350	60-36	190-210	110-130
70/21	310-365	60-38	200-220	120-140
80/27	315-370	65-38	205-225	120-150
90/32	320-375	65-38	210-225	130-150
100/38	380-500	70-45	220-250	135-155
110/43	405-520	75-46	230-250	140-160

Suction pressure drops gradually throughout the freeze cycle

K1350A SELF-CONTAINED AIR-COOLED

NOTE: These characteristics may vary depending on operating conditions.

CYCLE TIMES

Freeze Time + Harvest Time = Total Cycle Time

Air Temp. Entering Condenser °F/°C	Freeze Time			Harvest Time
	Water Temperature °F/°C			
	50/10	70/21	90/32	
70/21	10.7-12.6	12.1-14.2	13.8-16.2	1.0-2.5
80/27	11.2-13.2	12.5-14.7	13.1-15.4	
90/32	11.7-13.8	12.9-15.2	14.1-16.6	
100/38	12.8-15.1	14.1-16.6	15.5-18.2	
110/43	14.4-16.9	16.2-19.0	18.9-22.1	

Times in minutes

24 Hour Ice Production

Air Temp. Entering Condenser °F/°C	Water Temperature °F/°C		
	50/10	70/21	90/32
70/21	1540	1350	1190
80/27	1350	1215	1090
90/32	1235	1145	990
100/38	1160	1080	920
110/43	1040	950	870

Based on average ice slab weight of 12.75 - 14.75 lb (5.78– 6.69 kg)
230/50/1 production is approximately 12% lower than 230/60/1.

Operating Pressures

Air Temp. Entering Condenser °F/°C	Freeze Cycle		Harvest Cycle	
	Discharge Pressure PSIG	Suction Pressure PSIG	Discharge Pressure PSIG	Suction Pressure PSIG
50/10	300-380	66-34	165-190	125-135
70/21	300-380	66-34	165-190	125-135
80/27	315-410	73-36	175-205	130-140
90/32	330-450	81-39	185-220	135-150
100/38	375-490	91-42	200-240	150-170
110/43	420-530	101-46	230-260	165-185

Suction pressure drops gradually throughout the freeze cycle

K1350W SELF-CONTAINED WATER-COOLED

NOTE: These characteristics may vary depending on operating conditions.

CYCLE TIMES

Freeze Time + Harvest Time = Total Cycle Time

Air Temp. Around Ice Machine °F/°C	Freeze Time			Harvest Time
	Water Temperature °F/°C			
	50/10	70/21	90/32	
70/21	10.7-12.7	11.2-13.1	11.6-13.7	1.0-2.5
80/27	10.9-12.8	11.3-13.3	11.7-13.7	
90/32	11.0-13.0	11.4-13.4	11.8-13.8	
100/38	11.3-13.4	11.7-13.8	12.2-14.9	
110/43	11.6-13.7	12.1-14.2	12.7-14.9	

Times in minutes

24 Hour Ice Production

Air Temp. Around Ice Machine °F/°C	Water Temperature °F/°C		
	50/10	70/21	90/32
70/21	1510	1290	1215
80/27	1500	1280	1205
90/32	1495	1225	1190
100/38	1485	1210	1170
110/43	1470	1190	1140

Based on average ice slab weight of 12.75 - 14.75 lb (5.78 – 6.69 kg)
 Water regulating valve set to maintain 300 PSIG discharge pressure
 Condenser Water usage per 100 lbs ice = 160 gal (45 kg = 606 L)
 230/50/1 production is approximately 12% lower than 230/60/1.

Operating Pressures

Air Temp. Around Ice Machine °F/°C	Freeze Cycle		Harvest Cycle	
	Discharge Pressure PSIG	Suction Pressure PSIG	Discharge Pressure PSIG	Suction Pressure PSIG
50/10	290-305	64-36	150-165	110-125
70/21	290-305	64-36	150-165	110-125
80/27	290-310	68-37	155-175	110-125
90/32	295-335	72-39	160-180	110-125
100/38	305-335	73-41	160-180	110-130
110/43	310-340	74-44	165-185	115-130

Suction pressure drops gradually throughout the freeze cycle

K1350N REMOTE AIR-COOLED

NOTE: These characteristics may vary depending on operating conditions.

CYCLE TIMES

Freeze Time + Harvest Time = Total Cycle Time

Air Temp. Entering Condenser °F/°C	Freeze Time			Harvest Time
	Water Temperature °F/°C			
	50/10	70/21	90/32	
70/21	10.6-12.5	12.0-14.2	12.2-14.3	1.0-2.5
80/27	11.1-13.0	11.6-13.6	12.8-15.0	
90/32	11.2-13.2	11.3-13.4	12.5-16.0	
100/38	11.9-14.0	12.7-14.9	14.4-16.9	
110/43	12.8-15.0	13.9-16.3	15.3-18.0	

Times in minutes

24 Hour Ice Production

Air Temp. Entering Condenser °F/°C	Water Temperature °F/°C		
	50/10	70/21	90/32
70/21	1470	1295	1195
80/27	1410	1250	1175
90/32	1340	1200	1130
100/38	1280	1115	1040
110/43	1160	1095	975

Based on average ice slab weight of 12.75 - 14.75 lb (4.65 – 5.22 kg)
230/50/1 production is approximately 12% lower than 230/60/1.

Operating Pressures

Air Temp. Entering Condenser °F/°C	Freeze Cycle		Harvest Cycle	
	Discharge Pressure PSIG	Suction Pressure PSIG	Discharge Pressure PSIG	Suction Pressure PSIG
50/10	300-365	70-33	165-190	115-140
70/21	300-365	70-33	165-190	115-140
80/27	305-370	75-35	170-190	115-140
90/32	305-380	75-38	170-195	120-145
100/38	330-410	82-42	175-195	125-145
110/43	400-490	95-48	180-200	130-150

Suction pressure drops gradually throughout the freeze cycle

K1800A SELF-CONTAINED AIR-COOLED

NOTE: These characteristics may vary depending on operating conditions.

CYCLE TIMES

Freeze Time + Harvest Time = Total Cycle Time

Air Temp. Entering Condenser °F/°C	Freeze Time			Harvest Time
	Water Temperature °F/°C			
	50/10	70/21	90/32	
70/21	9.1-10.5	9.8-11.2	10.6-12.1	1.0-2.5
80/27	9.9-11.4	10.6-12.1	11.6-13.2	
90/32	11.0-12.5	11.4-13.0	12.7-14.5	
100/38	12.2-13.9	12.9-14.7	14.5-16.5	
110/43	13.6-15.5	14.9-16.9	16.4-18.6	

Times in minutes

24 Hour Ice Production

Air Temp. Entering Condenser °F/°C	Water Temperature °F/°C		
	50/10	70/21	90/32
70/21	1735	1630	1520
80/27	1610	1520	1410
90/32	1480	1430	1295
100/38	1350	1280	1155
110/43	1220	1125	1030

Based on average ice slab weight of 12.80 - 14.4 lb (5.8– 6.5 kg).
230/50/1 production is approximately 12% lower than 230/60/1.

Operating Pressures

Air Temp. Entering Condenser °F/°C	Freeze Cycle		Harvest Cycle	
	Discharge Pressure PSIG	Suction Pressure PSIG	Discharge Pressure PSIG	Suction Pressure PSIG
50/10	295-395	85-35	175-205	115-145
70/21	295-395	85-35	175-205	115-145
80/27	310-410	85-36	185-215	125-150
90/32	330-430	85-38	195-225	135-155
100/38	400-500	90-40	210-250	150-170
110/43	430-555	110-45	230-290	160-190

Suction pressure drops gradually throughout the freeze cycle

K1800N REMOTE AIR-COOLED

NOTE: These characteristics may vary depending on operating conditions.

CYCLE TIMES

Freeze Time + Harvest Time = Total Cycle Time

Air Temp. Entering Condenser °F/°C	Freeze Time			Harvest Time
	Water Temperature °F/°C			
	50/10	70/21	90/32	
70/21	9.5-10.8	10.1-11.5	10.7-12.2	1.0-2.5
80/27	10.0-11.5	10.7-12.2	11.5-13.1	
90/32	10.7-12.2	11.5-13.2	12.4-14.1	
100/38	11.4-13.0	12.3-14.0	13.3-15.2	
110/43	12.2-13.9	13.2-15.1	14.5-16.5	

Times in minutes

24 Hour Ice Production

Air Temp. Entering Condenser °F/°C	Water Temperature °F/°C		
	50/10	70/21	90/32
70/21	1680	1595	1510
80/27	1600	1510	1420
90/32	1515	1415	1330
100/38	1430	1335	1245
110/43	1345	1250	1150

Based on average ice slab weight of 12.8 - 14.4 lb (5.8 - 6.5 kg)
230/50/1 production is approximately 12% lower than 230/60/1.

Operating Pressures

Air Temp. Entering Condenser °F/°C	Freeze Cycle		Harvest Cycle	
	Discharge Pressure PSIG	Suction Pressure PSIG	Discharge Pressure PSIG	Suction Pressure PSIG
50/10	300-365	70-35	175-195	110-135
70/21	300-365	70-35	175-195	110-135
80/27	300-380	75-37	180-200	115-140
90/32	300-400	80-38	180-205	120-140
100/38	350-480	90-40	190-215	125-145
110/43	450-520	95-42	205-225	135-150

Suction pressure drops gradually throughout the freeze cycle

Diagrams

Wiring Diagrams

The following pages contain electrical wiring diagrams. Be sure you are referring to the correct diagram for the ice machine you are servicing.

Warning

Always disconnect power before working on electrical circuitry.

Wiring Diagram Legend

The following symbols are used on all of the wiring diagrams:

- * Internal Compressor Overload
(Some models have external compressor overloads)
- ** Fan Motor Run Capacitor
(Some models do not incorporate fan motor run capacitor)
- () Wire Number Designation
(The number is marked at each end of the wire)
- >>— Multi-pin Connection
(Electrical Box Side) —>>—
(Compressor Compartment Side)

K0250, K0350, K0420, K0500, K0600, K1000 1 PH SELF-CONTAINED AIR/WATER-COOLED

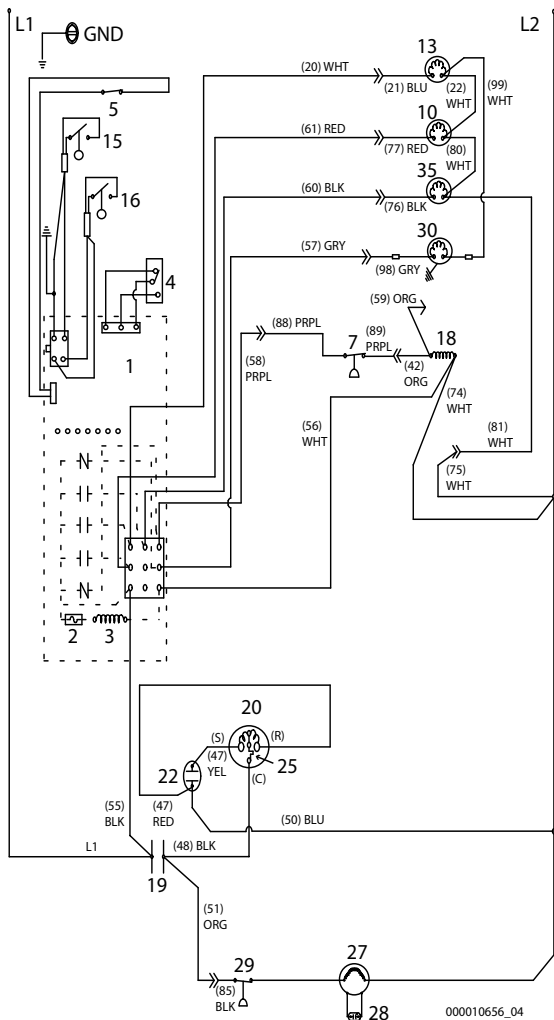

000010656_04

Number	Component
1	Control Board
2	Fuse
3	Transformer
4	On/Off/Clean Switch
5	Bin Switch
7	High Pressure Cutout
10	Harvest Solenoid Valve
13	Water Inlet Valve
15	Harvest Float switch
16	Water Level Float Switch
18	Contactora Coil
19	Contactora Contacts
20	Compressor
22	Compressor Run Capacitor
25	Compressor Overload
27	Condenser Fan Motor
28	Condenser Fan Motor Run Capacitor
29	Fan Cycle Control
30	Water Pump
35	Dump Valve
Wire Colors	
BLK	Black
BLU	Blue
BRN	Brown
GRY	Grey
ORG	Orange
PRPL	Purple
RED	Red
WHT	White
YEL	Yellow
Refer to control board schematic for control board detail	

K1000 1PH REMOTE AIR-COOLED CONDENSER

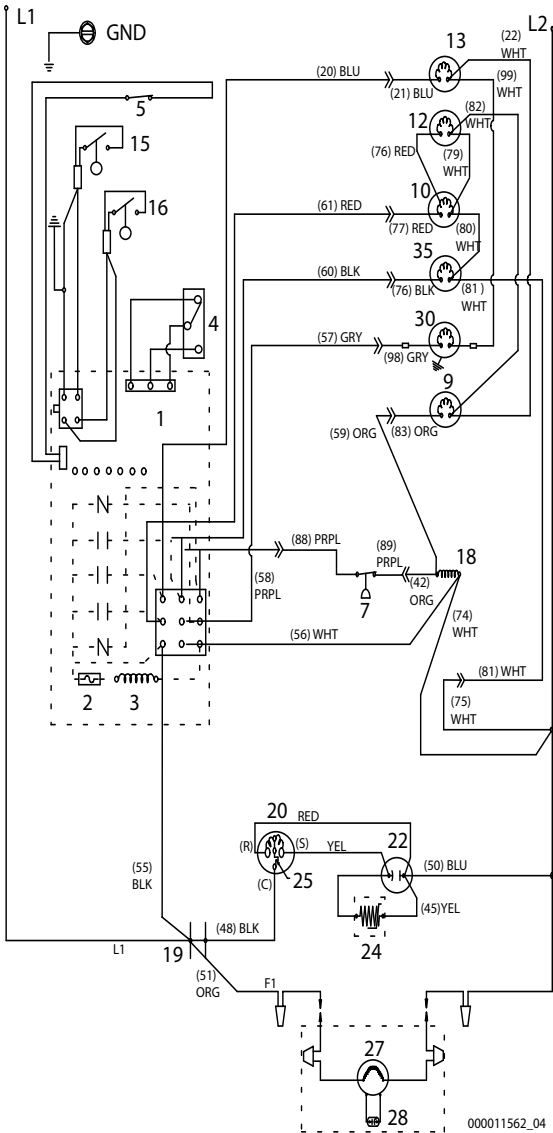

000011562_04

Number	Component
1	Control Board
2	Fuse
3	Transformer
4	On/Off/Clean Switch
5	Bin Switch
7	High Pressure Cutout
9	Liquid Line Solenoid valve
10	Harvest Solenoid Valve
12	Harvest Pressure Regulating Solenoid Valve
13	Water Inlet valve
15	Harvest Float switch
16	Water Level Float Switch
18	Contactora Coil
19	Contactora Contacts
20	Compressor
22	Compressor Run Capacitor
24	Compressor PTCR
25	Compressor Overload
27	Condenser Fan Motor
28	Condenser Fan Motor Run Capacitor
30	Water Pump
35	Dump Valve
Wire Colors	
BLK	Black
BLU	Blue
BRN	Brown
GRY	Grey
ORG	Orange
PRPL	Purple
RED	Red
WHT	White
YEL	Yellow
Refer to control board schematic for control board detail	

K1350, K1800 1 PH SELF-CONTAINED AIR/WATER-COOLED

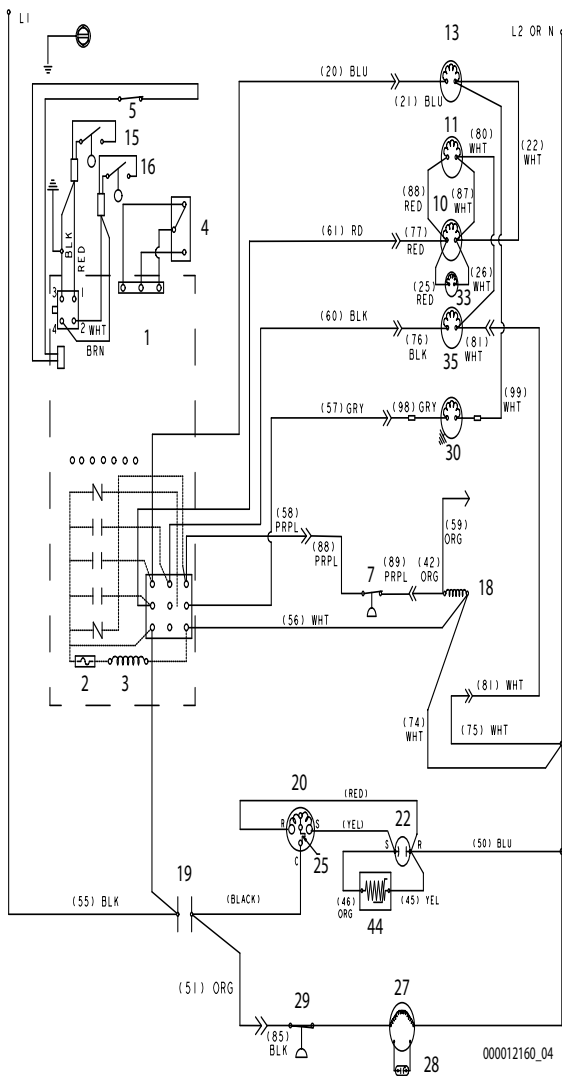

Number	Component
1	Control Board
2	Fuse
3	Transformer
4	On/Off/Clean Switch
5	Bin Switch
7	High Pressure Cutout
10	Harvest Solenoid Valve Left Side
11	Harvest Solenoid Valve Right Side
13	Water Inlet Valve
15	Harvest Float switch
16	Water Level Float Switch
18	Contactora Coil
19	Contactora Contacts
20	Compressor
22	Compressor Run Capacitor
24	Compressor PTCR
25	Compressor Overload
27	Condenser Fan Motor
28	Condenser Fan Motor Run Capacitor
29	Fan Cycle Control
30	Water Pump
33	Harvest Assist Air Pump
35	Dump Valve
Wire Colors	
BLK	Black
BLU	Blue
BRN	Brown
GRY	Grey
ORG	Orange
PRPL	Purple
RED	Red
WHT	White
YEL	Yellow
Refer to control board schematic for control board detail	

K1350, K1800 3PH SELF-CONTAINED AIR/WATER-COOLED

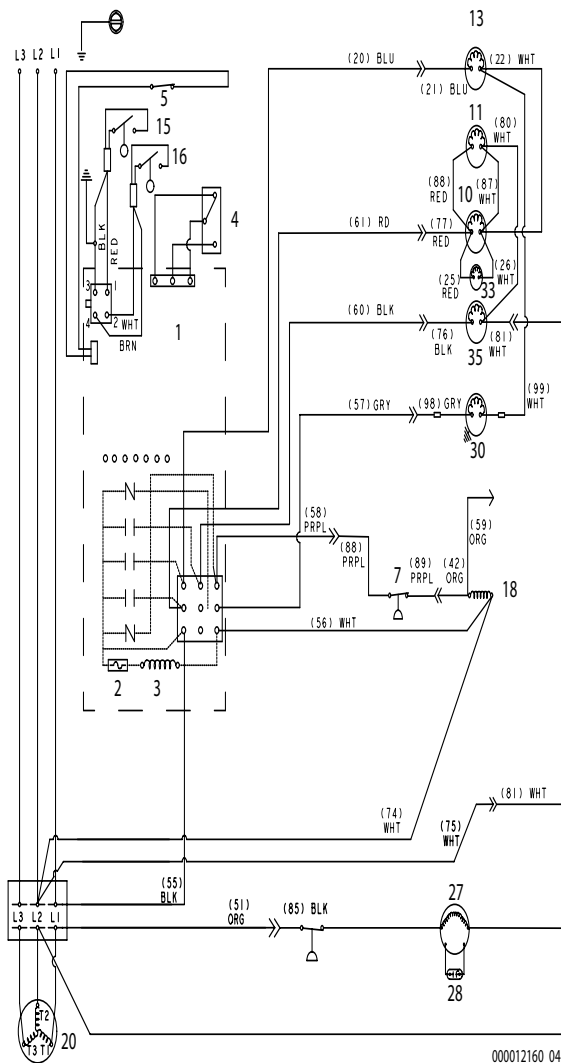

Number	Component
1	Control Board
2	Fuse
3	Transformer
4	On/Off/Clean Switch
5	Bin Switch
7	High Pressure Cutout
10	Harvest Solenoid Valve Left Side
11	Harvest Solenoid Valve Right Side
13	Water Inlet Valve
15	Harvest Float switch
16	Water Level Float Switch
18	Contactora Coil
19	Contactora Contacts
20	Compressor
22	Compressor Run Capacitor
24	Compressor PTCR
25	Compressor Overload
27	Condenser Fan Motor
28	Condenser Fan Motor Run Capacitor
29	Fan Cycle Control
30	Water Pump
33	Harvest Assist Air Pump
35	Dump Valve
Wire Colors	
BLK	Black
BLU	Blue
BRN	Brown
GRY	Grey
ORG	Orange
PRPL	Purple
RED	Red
WHT	White
YEL	Yellow
Refer to control board schematic for control board detail	

K1350, K1800 1 PH REMOTE AIR-COOLED CONDENSER

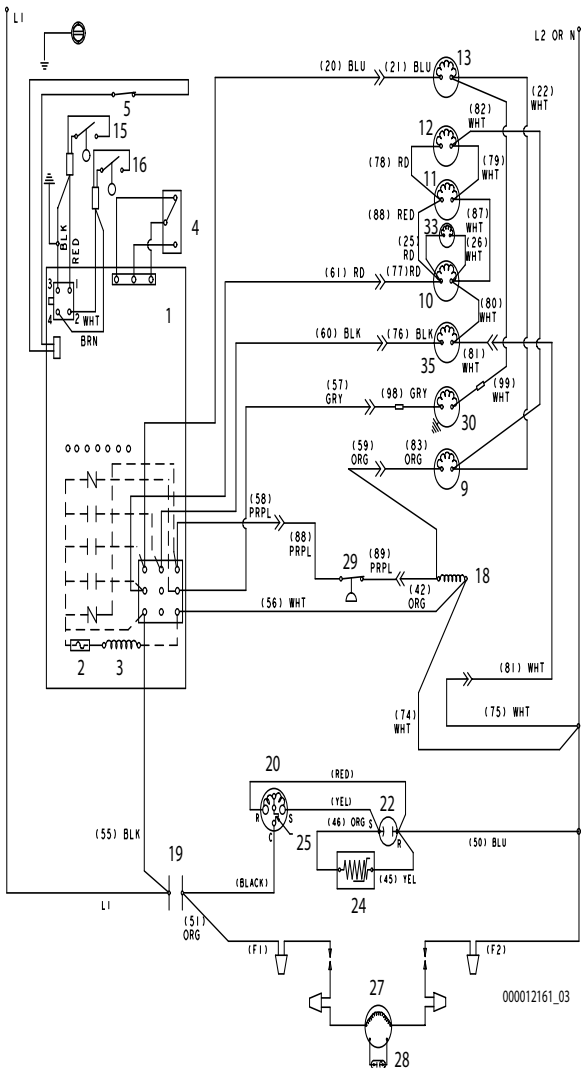

000012161_03

Number	Component
1	Control Board
2	Fuse
3	Transformer
4	On/Off/Clean Switch
5	Bin Switch
7	High Pressure Cutout
9	Liquid Line Solenoid valve
10	Harvest Solenoid Valve
12	Harvest Pressure Regulating Solenoid Valve
13	Water Inlet valve
15	Harvest Float switch
16	Water Level Float Switch
18	Contactora Coil
19	Contactora Contacts
20	Compressor
22	Compressor Run Capacitor
24	Compressor PTCR
25	Compressor Overload
27	Condenser Fan Motor
28	Condenser Fan Motor Run Capacitor
30	Water Pump
35	Dump Valve
Wire colors	
BLK	Black
BLU	Blue
BRN	Brown
GRY	Grey
ORG	Orange
PRPL	Purple
RED	Red
WHT	White
YEL	Yellow
Refer to control board schematic for control board detail	

K1350, K1800 3 PH REMOTE AIR-COOLED CONDENSER

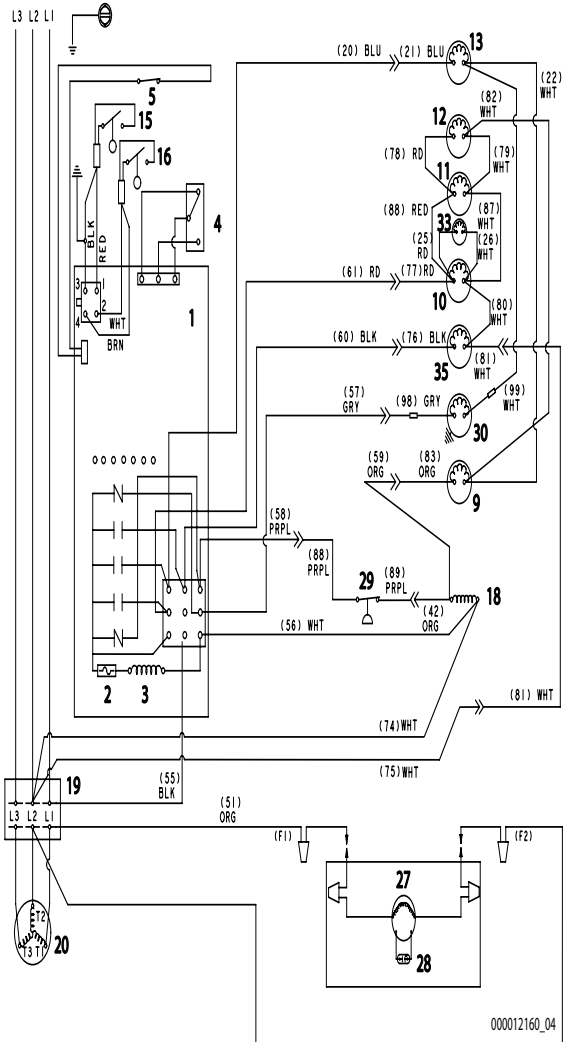

000012160_04

Number	Component
1	Control Board
2	Fuse
3	Transformer
4	On/Off/Clean Switch
5	Bin Switch
7	High Pressure Cutout
9	Liquid Line Solenoid valve
10	Harvest Solenoid Valve
12	Harvest Pressure Regulating Solenoid Valve
13	Water Inlet valve
15	Harvest Float switch
16	Water Level Float Switch
18	Contactora Coil
19	Contactora Contacts
20	Compressor
22	Compressor Run Capacitor
24	Compressor PTCR
25	Compressor Overload
27	Condenser Fan Motor
28	Condenser Fan Motor Run Capacitor
30	Water Pump
35	Dump Valve
Wire colors	
BLK	Black
BLU	Blue
BRN	Brown
GRY	Grey
ORG	Orange
PRPL	Purple
RED	Red
WHT	White
YEL	Yellow
Refer to control board schematic for control board detail	

ELECTRONIC CONTROL BOARD

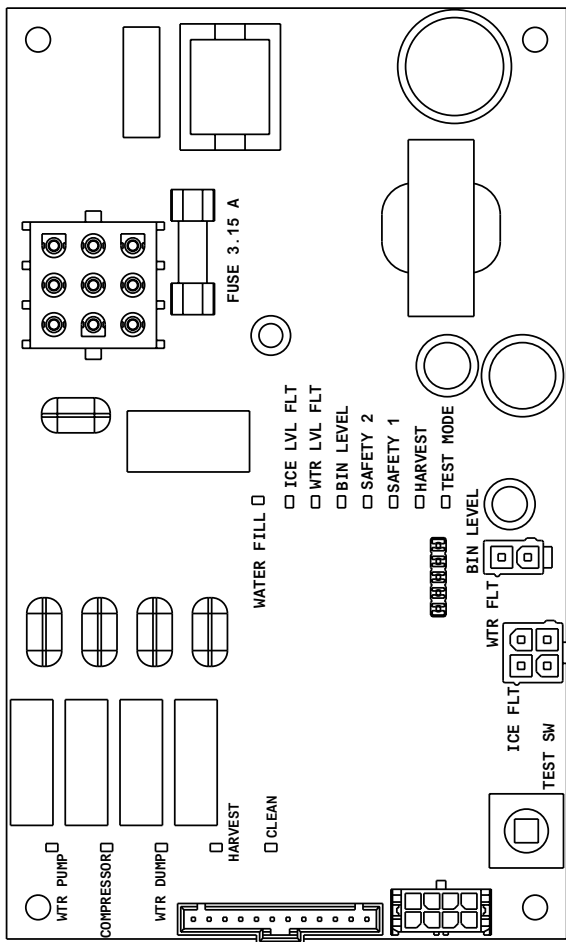

Refrigeration Tubing Schematics

SELF-CONTAINED AIR OR WATER-COOLED

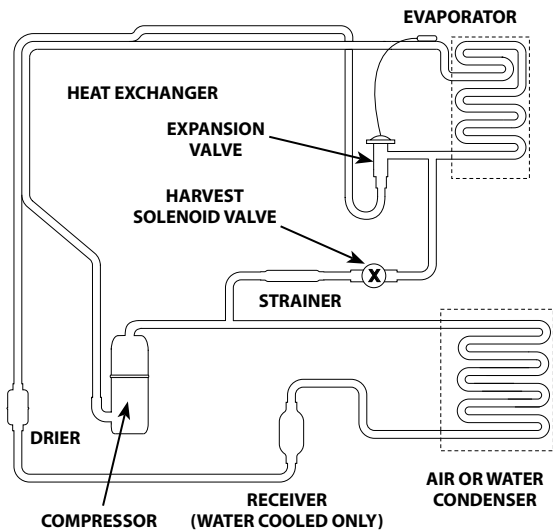

REMOTE AIR-COOLED

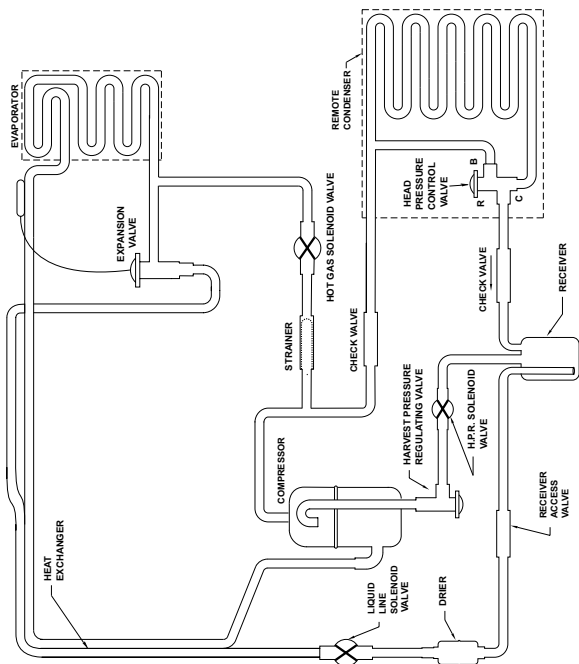

THIS PAGE INTENTIONALLY LEFT BLANK

THIS PAGE INTENTIONALLY LEFT BLANK

KOOLAIRE®

KOOLAIRE
ICE MACHINE DIVISION
2110 SOUTH 26TH STREET
MANITOWOC, WI 54220

800-545-5720
WWW.KOOL-AIRE.COM

Every new piece of Welbilt equipment comes with KitchenCare™ and you choose the level of service that meets your operational needs from one restaurant to multiple locations.

KitchenCare™

StarCare – Warranty & lifetime service, certified OEM parts, global parts inventory, performance audited

ExtraCare – CareCode, 24/7 Support, online/mobile product information

LifeCare – Install & equipment orientation, planned maintenance, KitchenConnect™, MenuConnect

Talk with KitchenCare™ • 1-844-724-CARE • www.welbilt.com

To learn how Welbilt and its leading brands can equip you, visit our global web site at www.welbilt.com, then discover the regional or local resources available to you.



©2017 Welbilt except where explicitly stated otherwise. All rights reserved. Continuing product improvement may necessitate change of specifications without notice.

Part Number 000014796 Rev00 5/17