



M&M Manufacturing Company

www.mmmfg.com

FORT WORTH (MkIV)
(817)-336-2311

FORT WORTH (Adolph)
(817)-334-0034

DALLAS
(972)-485-1504

HOUSTON
(713)-690-0585

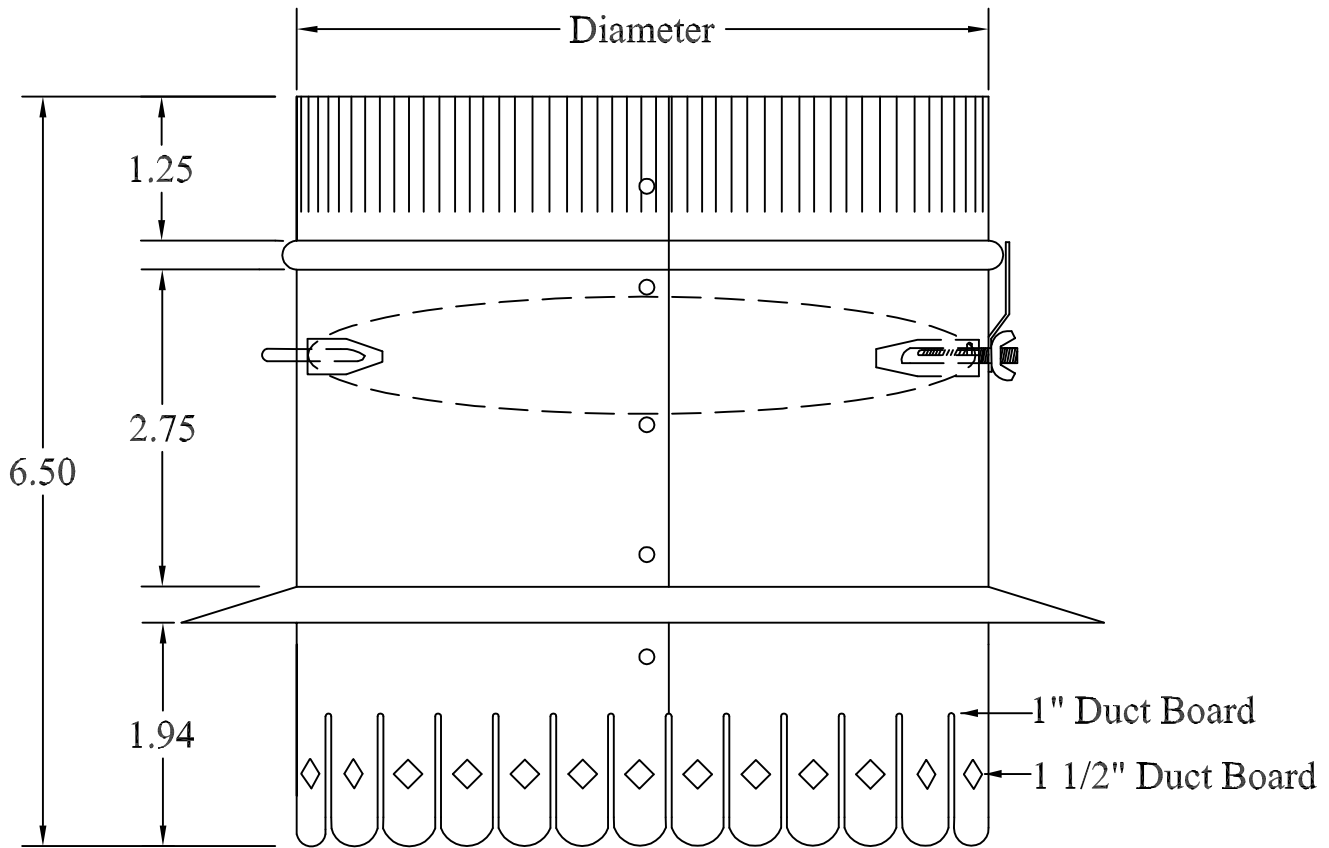
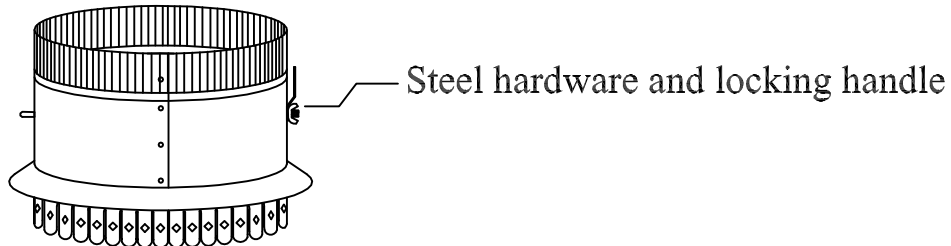

PART #: 507D(Size) | **DESCRIPTION:** Round metal starting collar w/damper for Ductboard

NOTES: Material: 4" - 10" = 30 ga.; 12" - 20" = 28 ga.

ASTM-A653 CS B galvanized steel

Order as Pt# 507D(diameter in inches)