



Mitchell Metal Products
Kosciusko, Mississippi
Established 1924

Highway 12E • P.O. Box 789 • Kosciusko, MS 39090
Office: 662-289-7110 or 800-258-6137 • Fax: 662-289-7112



Mitchell Metal Products, Inc.

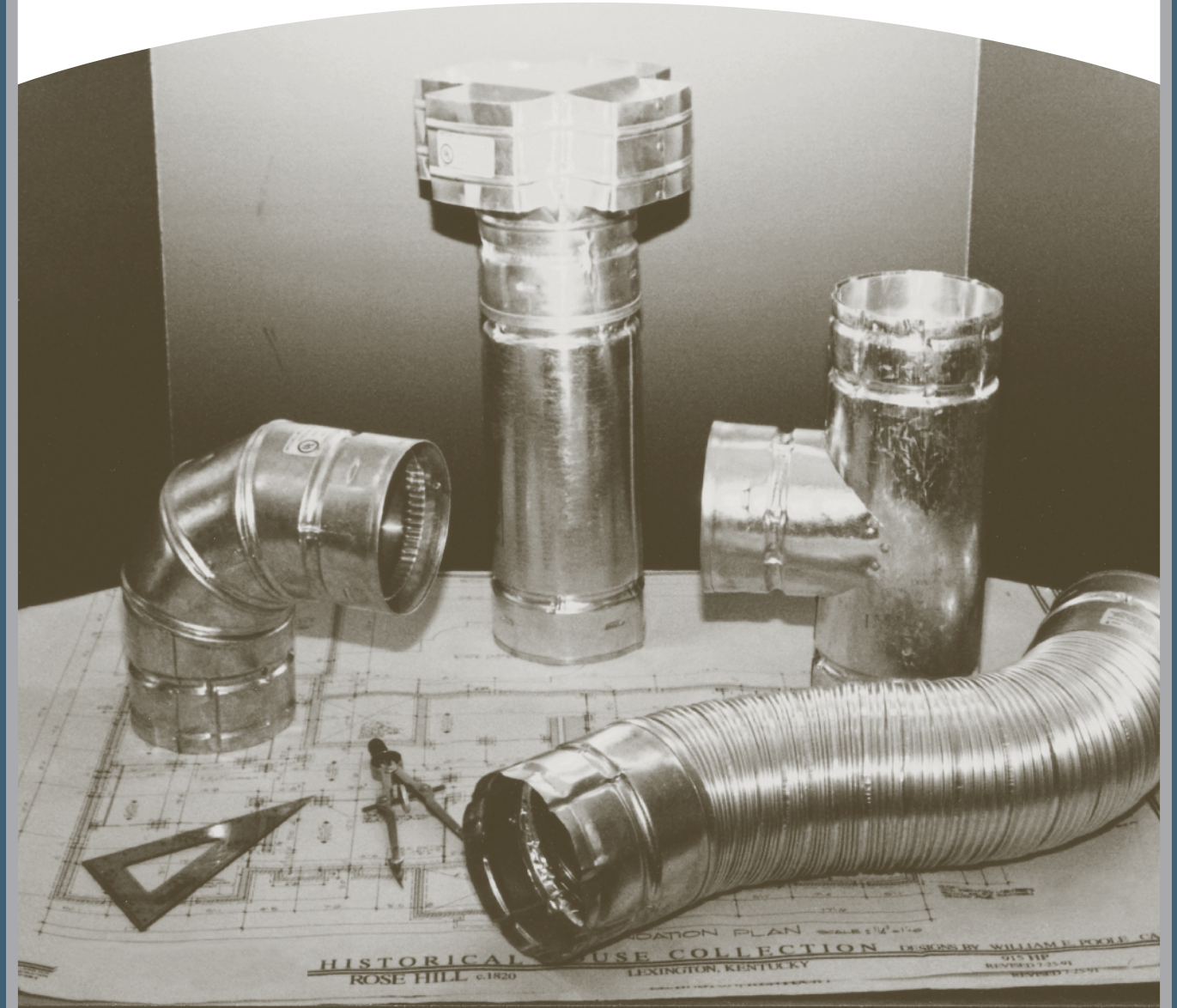

TYPE B GAS VENT SPECIFICATIONS



VENT PIPE

CATALOG	LENGTH	SIZE	SIZE		CATALOG	LENGTH	SIZE	SIZE			
DESCR.	SIZE	NOM. IN.	I.D.	O.D.	"A"	DESCR.	SIZE	NOM. IN.	I.D.	O.D.	"A"
P3x12	3"	11 3/4"	3"	3 1/2"	10"	P9x12	9"	11 1/2"	9"	10"	9 3/4"
P3x18	3"	17 3/4"	3"	3 1/2"	16"	P9x18	9"	17 1/2"	9"	10"	15 3/4"
P3x24	3"	23 3/4"	3"	3 1/2"	22"	P9x24	9"	23 1/2"	9"	10"	21 3/4"
P3x36	3"	35 3/4"	3"	3 1/2"	34"	P9x36	9"	35 1/2"	9"	10"	33 3/4"
P3x48	3"	47 3/4"	3"	3 1/2"	46"	P9x48	9"	47 1/2"	9"	10"	45 3/4"
P3x60	3"	59 3/4"	3"	3 1/2"	58"	P9x60	9"	59 1/2"	9"	10"	57 3/4"
P4x12	4"	11 3/4"	4"	4 1/2"	10"	P10x12	10"	11 1/2"	10"	11"	9 3/4"
P4x18	4"	17 3/4"	4"	4 1/2"	16"	P10x18	10"	17 1/2"	10"	11"	15 3/4"
P4x24	4"	23 3/4"	4"	4 1/2"	22"	P10x24	10"	23 1/2"	10"	11"	21 3/4"
P4x36	4"	35 3/4"	4"	4 1/2"	34"	P10x36	10"	35 1/2"	10"	11"	33 3/4"
P4x48	4"	47 3/4"	4"	4 1/2"	46"	P10x48	10"	47 1/2"	10"	11"	45 3/4"
P4x60	4"	59 3/4"	4"	4 1/2"	58"	P10x60	10"	59 1/2"	10"	11"	57 3/4"
P5x12	5"	11 3/4"	5"	5 1/2"	10"	P12x12	12"	11 1/2"	12"	13"	9 3/4"
P5x18	5"	17 3/4"	5"	5 1/2"	16"	P12x18	12"	17 1/2"	12"	13"	15 3/4"
P5x24	5"	23 3/4"	5"	5 1/2"	22"	P12x24	12"	23 1/2"	12"	13"	21 3/4"
P5x36	5"	35 3/4"	5"	5 1/2"	34"	P12x36	12"	35 1/2"	12"	13"	33 3/4"
P5x48	5"	47 3/4"	5"	5 1/2"	46"	P14x12	14"	11 1/2"	14"	15"	9 3/4"
P5x60	5"	59 3/4"	5"	5 1/2"	58"	P14x18	14"	17 1/2"	14"	15"	15 3/4"
P6x12	6"	11 3/4"	6"	6 1/2"	10"	P14x24	14"	23 1/2"	14"	15"	21 3/4"
P6x18	6"	17 3/4"	6"	6 1/2"	16"	P14x36	14"	35 1/2"	14"	15"	33 3/4"
P6x24	6"	23 3/4"	6"	6 1/2"	22"	P16x12	16"	11 1/2"	16"	17"	9 3/4"
P6x36	6"	35 3/4"	6"	6 1/2"	34"	P16x18	16"	17 1/2"	16"	17"	15 3/4"
P6x48	6"	47 3/4"	6"	6 1/2"	46"	P16x24	16"	23 1/2"	16"	17"	21 3/4"
P6x60	6"	59 3/4"	6"	6 1/2"	58"	P16x36	16"	35 1/2"	16"	17"	33 3/4"
P7x12	7"	11 3/4"	7"	7 1/2"	10"	P18x12	18"	11 1/2"	18"	19"	9 3/4"
P7x18	7"	17 3/4"	7"	7 1/2"	16"	P18x18	18"	17 1/2"	18"	19"	15 3/4"
P7x24	7"	23 3/4"	7"	7 1/2"	22"	P18x24	18"	23 1/2"	18"	19"	21 3/4"
P7x36	7"	35 3/4"	7"	7 1/2"	34"	P18x36	18"	35 1/2"	18"	19"	33 3/4"
P7x48	7"	47 3/4"	7"	7 1/2"	46"	P20x12	20"	11 1/2"	20"	21"	9 3/4"
P7x60	7"	59 3/4"	7"	7 1/2"	58"	P20x18	20"	17 1/2"	20"	21"	15 3/4"
P8x12	8"	11 3/4"	8"	8 1/2"	10"	P20x24	20"	23 1/2"	20"	21"	21 3/4"
P8x18	8"	17 3/4"	8"	8 1/2"	16"	P20x36	20"	35 1/2"	20"	21"	33 3/4"
P8x24	8"	23 3/4"	8"	8 1/2"	22"	P22x12	22"	11 1/2"	22"	23"	9 3/4"
P8x36	8"	35 3/4"	8"	8 1/2"	34"	P22x18	22"	17 1/2"	22"	23"	15 3/4"
P8x48	8"	47 3/4"	8"	8 1/2"	46"	P22x24	22"	23 1/2"	22"	23"	21 3/4"
P8x60	8"	59 3/4"	8"	8 1/2"	58"	P22x36	22"	35 1/2"	22"	23"	33 3/4"
P24x12	24"	11 1/2"	24"	25"	9 3/4"	P24x18	24"	17 1/2"	24"	25"	15 3/4"
P24x18	24"	17 1/2"	24"	25"	15 3/4"	P24x24	24"	23 1/2"	24"	25"	21 3/4"
P24x24	24"	23 1/2"	24"	25"	21 3/4"	P24x36	24"	35 1/2"	24"	25"	33 3/4"
P24x36	24"	35 1/2"	24"	25"	33 3/4"						

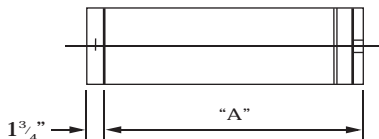

P24x12	24"	11 1/2"	24"	25"	9 3/4"
P24x18	24"	17 1/2"	24"	25"	15 3/4"
P24x24	24"	23 1/2"	24"	25"	21 3/4"
P24x36	24"	35 1/2"	24"	25"	33 3/4"

90 DEGREE ELBOWS

CATALOG DESCRIPTION	SIZE	"A"	"B"
E3	3"	6"	4 1/2"
E4	4"	7"	4 3/4"
E5	5"	8"	5 1/4"
E6	6"	8"	6"
E7	7"	9"	6 1/4"
E8	8"	9 1/2"	7 3/4"

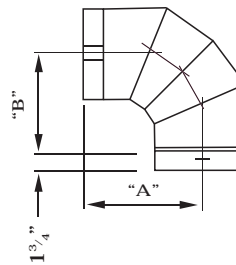

45-60 DEGREE ANGLES

CATALOG DESCRIPTION	SIZE	"A"	"B"
A3	3"	4 1/4"	2 1/2"
A4	4"	5"	3"
A5	5"	5 1/4"	3 1/2"
A6	6"	5 1/2"	3 3/4"
A7	7"	5 3/4"	4"
A8	8"	6"	4 1/4"
A9	9"	6 1/2"	4 3/4"
A10	10"	6 1/2"	4 3/4"
A12	12"	6 1/2"	4 3/4"
A14	14"	6 1/2"	5"
A16	16"	6 1/2"	5 1/2"
A18	18"	7"	6"
A20	20"	7 1/2"	6 1/4"
A22	22"	8 1/2"	7"
A24	24"	8 1/4"	7"

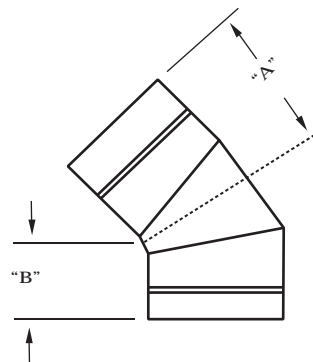

ADJUSTABLE LENGTH

CATALOG DESCRIPTION	SIZE I.D.	SIZE O.D.	"A"	"B"*
AL3x12	3"	3 1/2"	11 1/2"	6"
AL4x12	4"	4 1/2"	11 1/2"	6"
AL5x12	5"	5 1/2"	11 1/2"	6"
AL6x12	6"	6 1/2"	11 1/2"	6"
AL7x12	7"	7 1/2"	11 1/2"	6"
AL8x12	8"	8 1/2"	11 1/2"	6"
AL9x12	9"	10"	12"	6"
AL10x12	10"	11"	12"	6"
AL12x12	12"	13"	12"	6"
AL14x12	14"	15"	12"	6"
AL16x12	16"	17"	12"	6"
AL18x12	18"	19"	12"	6"
AL20x12	20"	21"	12"	6"
AL22x12	22"	23"	12"	6"
AL24x12	24"	25"	12"	6"

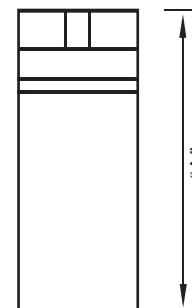

*A=total length

*B=Number of inches adjustable

TEES

CATALOG DESCRIPTION	SIZE	"A"	"B"	"C"	"D"
T3	3"	9"	3"	4"	5 1/2"
T4	4"	10 1/4"	3 1/2"	4"	6"
T5	5"	10 1/2"	4"	4 1/2"	6"
T6	6"	12"	4 1/2"	5"	7"
T7	7"	12 3/4"	5"	5 1/2"	7"
T8	8"	13"	5 1/2"	5 1/2"	7 1/2"
T9	9"	21 3/4"	7"	11 3/4"	10"
T10	10"	21 3/4"	8"	11 3/4"	10"
T12	12"	21 3/4"	9"	11 3/4"	10"
T14	14"	27 3/4"	10"	14 3/4"	13"
T16	16"	27 3/4"	11"	14 3/4"	13"
T18	18"	27 3/4"	12"	14 3/4"	13"
T20	20"	33 3/4"	13"	17 3/4"	16"
T22	22"	33 3/4"	14"	17 3/4"	16"
T24	24"	33 3/4"	15"	17 3/4"	16"

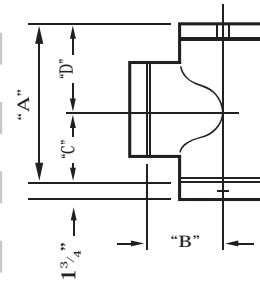

TEE CAPS

CATALOG DESCRIPTION	"A"	"B"
TC3	2"	3 1/2"
TC4	2"	4 1/2"
TC5	2"	5 1/2"
TC6	2"	6 1/2"
TC7	2"	7 1/2"
TC8	2"	8 1/2"
TC9	2"	10"
TC10	2"	11"
TC12	2"	13"
TC14	2"	15"
TC16	2"	17"
TC18	2"	19"
TC20	2"	21"
TC22	2"	23"
TC24	2"	25"

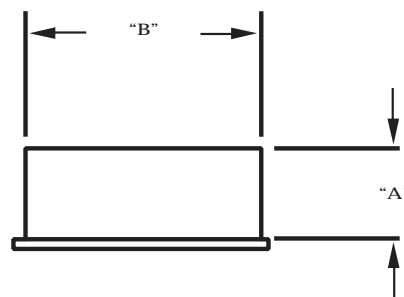

DRAFT HOOD CONNECTOR

CATALOG				
DESCRIPTION	SIZE	I.D.	O.D.	"A"
DHC3	3"	3"	3 1/2"	5"
DHC4	4"	4"	4 1/2"	5"
DHC5	5"	5"	5 1/2"	5"
DHC6	6"	6"	6 1/2"	5"
DHC7	7"	7"	7 1/2"	5"
DHC8	8"	8"	8 1/2"	5"
DHC10	10"	10"	11"	8"
DHC12	12"	12"	13"	8"
DHC14	14"	14"	15"	8"
DHC16	16"	16"	17"	8"
DHC18	18"	18"	19"	8"
DHC20	20"	20"	21"	8"
DHC22	22"	22"	23"	8"
DHC 24	24"	24"	25"	8"

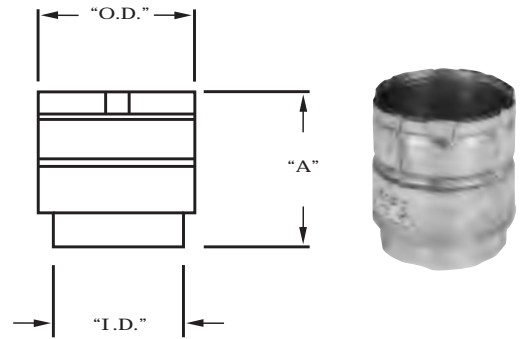

CATALOG			
DESCRIPTION	"A"	"B"	"C"
EDHC3	6"	4 1/2"	3/4"
EDHC4	7"	4 3/4"	3/4"
EDHC5	8"	5 1/4"	3/4"
EDHC6	8"	6"	3/4"
EDHC7	9"	6 1/4"	3/4"
EDHC8	9 1/2"	7 3/4"	3/4"

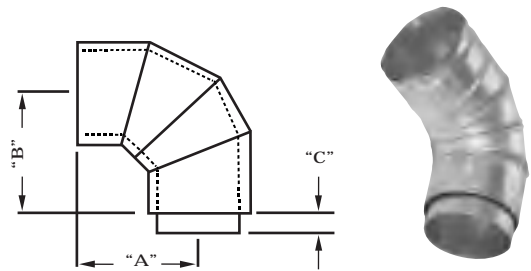

INCREASERS

CATALOG DESCRIPTION	INLET	OUTLET	"A"
I3x4	3"	4"	6 1/2"
I3x5	3"	5"	6"
I3x6	3"	6"	7"
I3x7	3"	7"	8"
I3x8	3"	8"	9 1/2"
I4x5	4"	5"	7"
I4x6	4"	6"	7"
I4x7	4"	7"	7 1/2"
I4x8	4"	8"	9 1/4"
I5x6	5"	6"	7 1/4"
I5x7	5"	7"	7 1/2"
I5x8	5"	8"	7 1/4"
I5x9	5"	9"	11"
I5x10	5"	10"	12 1/2"
I6x7	6"	7"	7 1/4"
I6x8	6"	8"	7"
I6x9	6"	9"	10 1/2"
I6x10	6"	10"	13"
I6x12	6"	12"	14"
I6x14	6"	14"	15"
I7x8	7"	8"	7"
I7x9	7"	9"	9 1/4"
I7x10	7"	10"	9 1/4"
I7x12	7"	12"	12"
I8x9	8"	9"	9 1/4"
I8x10	8"	10"	9"
I8x12	8"	12"	12 1/4"
I8x14	8"	14"	12 7/8"
I9x10	9"	10"	10"
I9x12	9"	12"	12 1/2"
I19x14	9"	14"	12 1/2"
I10x12	10"	12"	10 1/2"
I10x14	10"	14"	11 1/4"
I10x16	10"	16"	14 1/4"
I12x14	12"	14"	10 1/2"
I12x16	12"	16"	11 3/4"
I14x16	14"	16"	10 1/2"
I14x18	14"	18"	11 3/4"
I14x20	14"	20"	14 3/4"
I16x18	16"	18"	9 3/4"
I16x22	16"	22"	16 3/4"

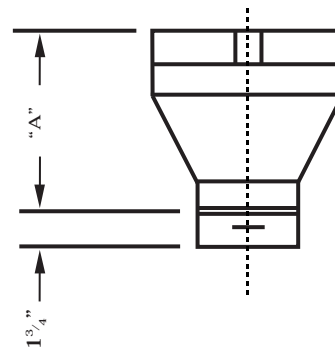

SPLIT TYPE STORM COLLAR

DESCRIPTION	I.D.	O.D.
SCNS3	3 1/2"	7 3/4"
SCNS4	4 1/2"	8 3/4"
SCNS5	5 1/2"	9 3/4"
SCNS6	6 1/2"	10 3/4"
SCNS7	7 1/2"	11 3/4"
SCNS8	8 1/2"	12 3/4"
SCNS9	10"	15 1/4"
SCNS10	11"	16 1/4"
SCNS12	13"	18 1/4"
SCNS14	15"	20 1/4"
SCNS16	17"	22 1/4"
SCNS18	19"	24 1/4"
SCNS20	21"	26 1/4"
SCNS22	23"	28 1/4"
SCNS24	25"	30 1/4"

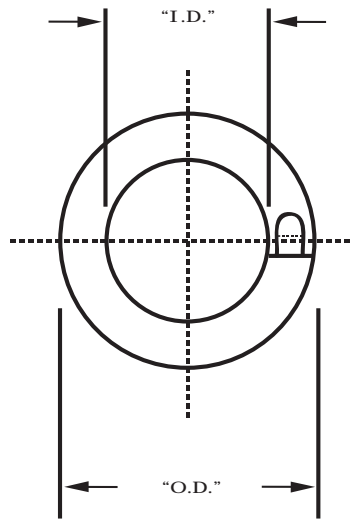

SOLID TYPE STORM COLLAR

DESCRIPTION	I.D.	O.D.
SCPS3	3 1/2"	7"
SCPS4	4 1/2"	8 1/4"
SCPS5	5 1/2"	9 1/4"
SCPS6	6 1/2"	10 1/2"
SCPS7	7 1/2"	11 1/2"
SCPS8	8 1/2"	12 1/2"

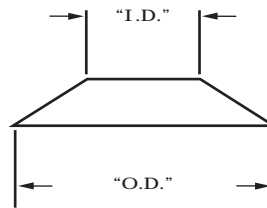

CEILING PLATE

DESCRIPTION	SIZE	O.D.
ES3	3"	8 1/2"
ES4	4"	9 1/2"
ES5	5"	10 1/2"
ES6	6"	11 1/2"
ES7	7"	12 1/2"
ES8	8"	13 1/2"
ES9	9"	16"
ES10	10"	17"
ES12	12"	19"
ES14	14"	21"
ES16	16"	23"
ES18	18"	25"
ES20	20"	27"
ES22	22"	29"
ES24	24"	31"

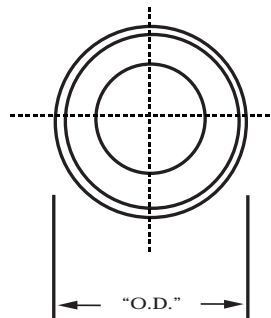

SQUARE CAPS

CATALOG DESCRIPTION	SIZE	"A"
C3	3"	5 1/8"
C4	4"	6 7/8"
C5	5"	8 1/8"
C6	6"	8 7/8"
C7	7"	9 1/2"
C8	8"	11 1/4"

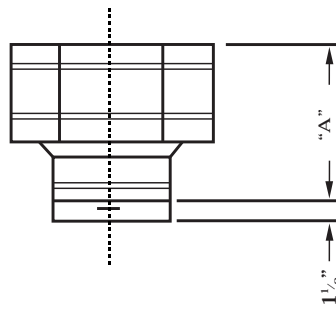

ROUND CAPS

CATALOG DESCRIPTION	SIZE	"A"
CR3	3"	6 1/2"
CR4	4"	7 5/8"
CR5	5"	8 3/8"
CR6	6"	9"
CR7	7"	11"
CR8	8"	12 1/8"
CR9	9"	11"
CR10	10"	13 3/4"
CR12	12"	17 3/4"
CR14	14"	18 1/4"
CR16	16"	20 3/4"
CR18	18"	22 3/4"
CR20	20"	23 1/4"
CR22	22"	24 3/4"
CR24	24"	26"

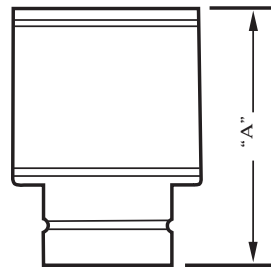

VENTILATED THIMBLE

DESCRIPTION	"A" MIN.	"A" MAX.	"B"	"C" WALL OPENING
VT3	3"	5 1/2"	8 1/2"	6"
VT4	3"	5 1/2"	9 1/2"	7"
VT5	3"	5 1/2"	10 1/2"	8"
VT6	3"	5 1/2"	11 1/2"	9"
VT7	3"	5 1/2"	12 1/2"	10"
VT8	3"	5 1/2"	13 1/2"	11"
VT9	3"	5 1/2"	17"	13"
VT10	3"	5 1/2"	18"	14"
VT12	3"	5 1/2"	20"	16"
VT14	3"	5 1/2"	22"	18"
VT16	3"	5 1/2"	24"	20"
VT18	3"	5 1/2"	26"	22"
VT20	3"	5 1/2"	28"	24"
VT22	3"	5 1/2"	30"	26"
VT24	3"	5 1/2"	32"	28"

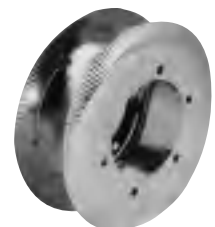
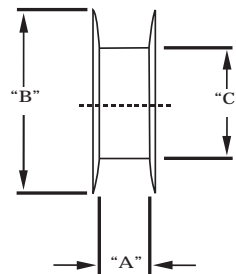

ADJUSTABLE ROOF FLASHINGS

DESCRIPTION	"A"	"B"	"C"
AF3	15"x15"	8 1/2"	4"
AF4	15"x15"	9 1/2"	4"
AF5	15"x15"	9 1/2"	4 1/4"
AF6	18"x18"	10 1/2"	4 1/2"
AF7	18"x18"	11 3/4"	4 3/4"
AF8	20"x20"	12 1/2"	4 3/4"
AF9	22"x22"	13 3/4"	6"
AF10	24"x24"	15"	4 3/4"
AF12	26"x26"	15 1/2"	6"
AF14	34"x34"	24"	7 3/4"
AF16	36"x36"	26"	6 3/4"
AF18	36"x36"	26 1/2"	7"
AF20	40"x40"	30 1/2"	6 1/2"
AF22	44"x44"	33"	6 1/2"
AF24	46"x46"	36"	6 1/2"

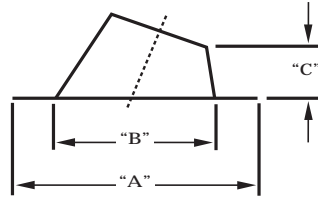

SPECIAL ROOF FLASHING

DESCRIPTION	"A"	"B"	"C"
SF3	15"	9 1/2"	4 3/4"
SF4	16"	9 5/8"	4 3/4"
SF5	17"	10 1/4"	4 3/4"
SF6	20"	12 3/4"	4 3/4"
SF7	20"	13 3/4"	4 3/4"
SF8	22"	15"	4 3/4"

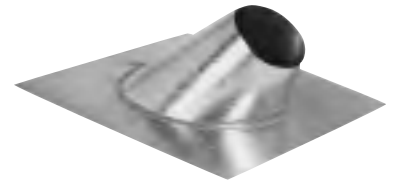
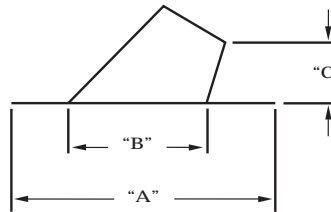

TALL CONE FLASHING

DESCRIPTION	"A"	"B"	"C"
TF3	15"	6 1/2"	12"
TF4	15"	7 1/2"	12"
TF5	15"	8 1/2"	12"
TF6	16"	9 1/2"	12"
TF7	17"	10 1/2"	12"
TF8	18"	11 1/2"	12"

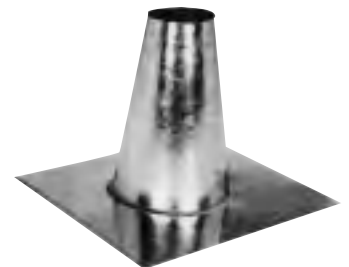
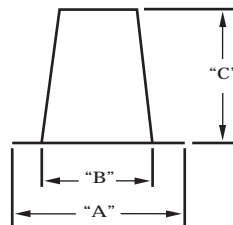

FIRESTOP

CATALOG DESCRIPTION	SIZE	"A"	"B"
F3	3"	6"	24"
F4	4"	7"	24"
F5	5"	8"	24"
F6	6"	9"	24"
F7	7"	10"	24"
F8	8"	11"	24"
F9	9"	13 1/2"	24"
F10	10"	14 1/2"	24"
F12	12"	16 1/2"	24"
F14	14"	18 1/2"	24"
F16	16"	20 1/2"	24"
F18	18"	22 1/2"	24"
F20	20"	24 1/2"	24"
F22	22"	26 1/2"	24"
F24	24"	28 1/2"	24"

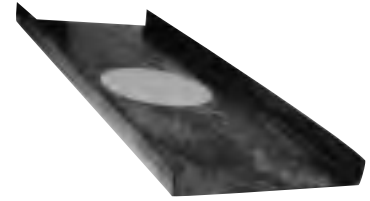
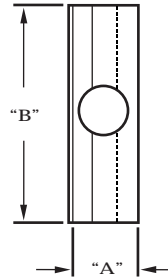

MITCH FLEX GAS VENT CONNECTOR

CATALOG DESCRIPTION	SIZE	"A"	"B"
FV 3 - 1	3"x1'	1'	3 1/2"
FV 3 - 2	3"x2'	2'	3 1/2"
FV 3 - 3	3"x3'	3'	3 1/2"
FV 3 - 4	3"x4'	4'	3 1/2"
FV 3 - 5	3"x5'	5'	3 1/2"
FV 4 - 1	4"x1'	1'	4 1/2"
FV 4 - 2	4"x2'	2'	4 1/2"
FV 4 - 3	4"x3'	3'	4 1/2"
FV 4 - 4	4"x4'	4'	4 1/2"
FV 4 - 5	4"x5'	5'	4 1/2"
FV 5 - 1	5"x1'	1'	5 1/2"
FV 5 - 2	5"x2'	2'	5 1/2"
FV 5 - 3	5"x3'	3'	5 1/2"
FV 5 - 4	5"x4'	4'	5 1/2"
FV 5 - 5	5"x5'	5'	5 1/2"

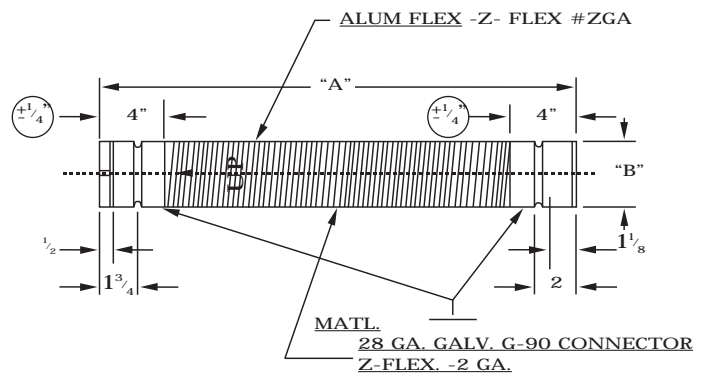

MITCHELL METAL PRODUCTS, INC.

INSTALLATION & ASSEMBLY INSTRUCTIONS FOR TYPE B GAS VENT SIZES 3" THROUGH 24" UL LISTED

I. GAS APPLIANCES WHICH MAY BE CONNECTED TO TYPE B GAS VENTS:

Mitchell Metal Type B gas vents may be used to vent listed appliances intended to burn only gas except as provided in Section II below. All vent installations shall be in accordance with their listing as detailed in these installation instructions. Appliances which may be vented with these vents include:

- A. Attic Furnaces
- B. Central Warm-Air Furnaces
- C. Duct Furnaces
- D. Floor Furnaces
- E. Room (Space) Heaters
- F. Unit Heaters
- G. Water Heaters
- H. Hot Water Boilers
- I. Steam Boilers

II. GAS APPLIANCES WHICH MUST BE CONNECTED TO CHIMNEYS

DO NOT USE TYPE B GAS VENT

- A. Incinerators
- B. Any appliance which may be readily converted to use a solid or liquid fuel
- C. Conversion Burners
- D. Gas Oil Burners
- E. Unlisted Appliances

III. STEP-BY-STEP INSTALLATION PROCEDURE FOR TYPE B GAS VENT

A. Assembling of Mitchell Metal pipe sections 3” through 24” (See Illustration 1)

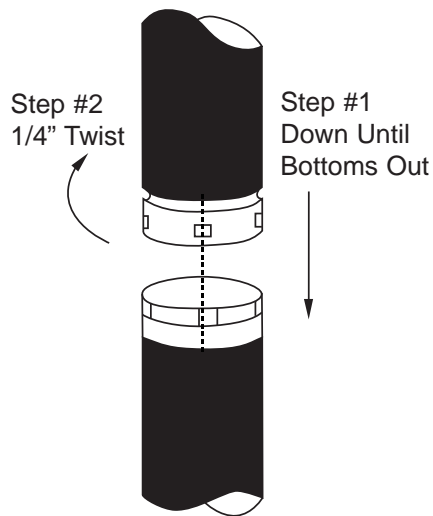

Illustration 1

1. Line up vent pipe ends so that a locking pierce is directly above a locking slot. All other pierces will fall in line with a locking slot immediately. (Up arrow must point up and away from appliance.)
2. Push female end of pipe until it bottoms out, then twist left turn
3. Pipe is ready for installation.
4. To unlock joints, twist female pipe back to original position and pipe will unlock.

B. Erection of the vent

1. In locating the appliance, **the recommendations of the appliance manufacturer, and applicable local codes should be complied with.** The appliance should be located in such a way as to allow for the best heating distribution and close proximity to the vertical vent which is to be run through the roof.
2. The vent and vent connector used should be the same size as the outlet of the draft hood supplied by the manufacturer of the gas fired appliance or size recommended by the manufacturer of the appliance.
3. Place Mitchell Metal Draft Hood Connector on the outlet of the draft hood of the appliance. Sheet metal screws should be used to fasten aluminum portion of DHC to the draft hood collar.

NOTE:

1. **3” through 8” sizes must have 1” clearance to combustibles**
2. **9” through 24” sizes must have 1½” clearance to combustibles**

4. Whenever possible, vertical runs should be used
Where this is not possible, keep these rules in mind:

- a. Avoid bends which would create excessive resistance to vent gases.
- b. Maintain a pitch or rise from appliance to vent on horizontal runs. In no case shall the pitch be less than 1/4" to the foot.
- c. Horizontal runs should be as short as possible. The maximum length of horizontal runs shall not exceed 75% of the height of the vent.

C. Vertical vent pipe and fittings

1. Unless the vent rises vertically from the draft hood, the vertical position is started with a Mitchell Metal Tee (Capping the bottom of the tee with a Mitchell Metal Tee Cap). The tee should be securely fastened with metal straps or perforated band iron making sure to maintain a minimum clearance of 1" for 3" through 8", and a minimum 1 1/2" clearance for 9" through 24" from all combustibles.(See Illustration 3)

2. Straight lengths of Mitchell Metal Pipe are snapped in place (as in Illustration 3) on top of tee.

3. Surface of vent pipe must have proper clearance from all combustible construction. Metal straps or perforated band iron should be used to secure and maintain this clearance. (See Illustration 3)

4. Whenever possible, vents should be run vertically through attic spaces for top efficiency. If lateral runs are necessary, run with as much rise as possible using Mitchell Metal 45 degree or 60 degree elbows to assure maximum rise. Lateral runs should be supported with metal straps or perforated band iron and again one inch clearance must be maintained from all combustible materials for sizes 3" - 8" and 1 1/2" clearance must be maintained from all combustible materials for sizes 9" through 24". (See Illustration 3)

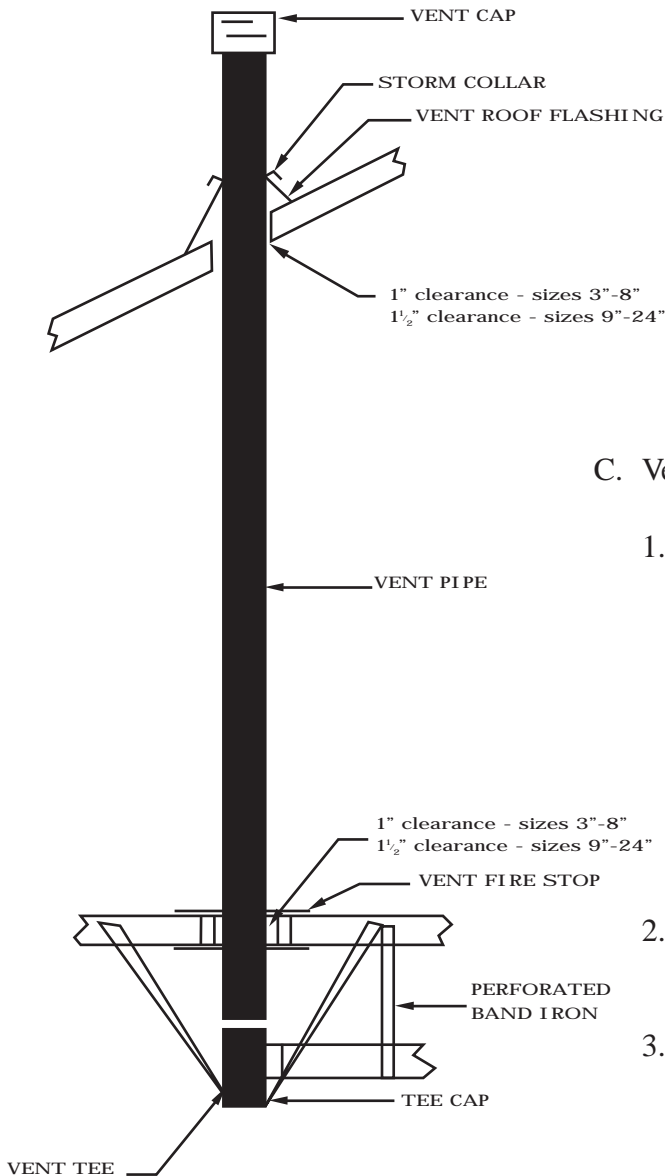

Illustration 3

NOTE:

1. 3" through 8" sizes must have 1" clearance to combustibles
2. 9" through 24" sizes must have 1 1/2" clearance to combustibles

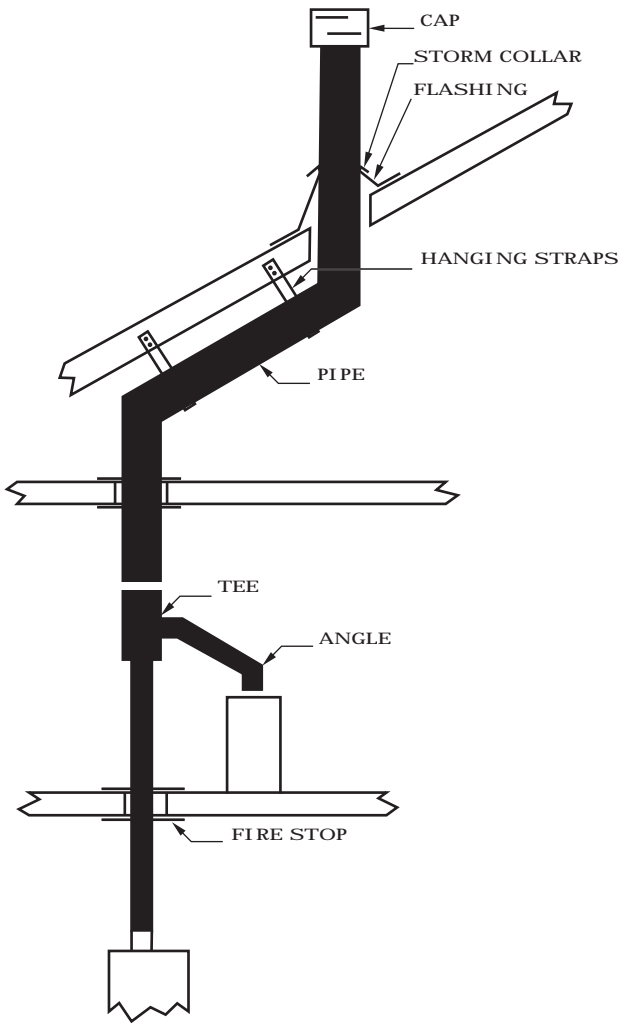

Illustration 4

NOTE:

1. 3" through 8" sizes must have 1" clearance to combustibles
2. 9" through 24" sizes must have 1½" clearance to combustibles

5. Where vent passes through the roof, the sheathing should be cut away to insure a minimum of one inch clearance from the vent pipe. The vent pipe should be run through the opening so that the top of the run is extended according to the chart listed in Section VII. At this point, a Mitchell Metal Roof Flashing is placed over the top of the vent and adjusted to maintain the necessary clearance from combustibles. Fasten the flashing to the roof and apply plastic cement at the point where vent passes through the roof flashing. Place a Mitchell Metal Storm Collar directly above the roof flashing and apply plastic cement at joint. The storm collar acts as a counter flashing. (See Illustrations 3 and 4)

6. The location selected for the vent top can have a significant influence on proper draft performance. On a windy day, nearby obstructions such as a wall or tree can create a zone of high pressure. When the vent cap is located in these high pressure zones the vent becomes highly susceptible to windy conditions and may tend to back draft. In those cases when the vent must be installed in a position less than 8 feet from a wall, parapet, or other obstruction, the vent cap must be located at least two feet above the obstruction. High pressure zones can also be created by wind striking the roof itself. For roofs from flat to 7/12 pitch, the vent cap should be positioned at least one foot above the roof surface. As indicated in Illustration 5, measure the vertical distance between the roof surface and the lowest discharge opening on the vent cap. As the roof pitch increases above 7/12, the roof begins to act more like a wall, and the pressure zone increases. To compensate for this, it is necessary to increase the height of the vent. The steeper the roof, the greater the vent height required to avoid the high pressure zone. Refer to the chart listed in Section VII.

7. Mitchell Metal Cap should be used on all vent installations to prevent back drafts and to keep out rain and debris.

D. Framing to isolate vents from insulation

1. When running vents through insulated areas, care must be taken to prevent insulation from coming in contact with vent pipe. This may be done by framing the opening through which a vent pipe is being run, maintaining proper clearance.
2. Nail sheet metal firestop on top of framing to prevent insulation from falling into boxed-in areas. (See Illustrations 3 and 4)

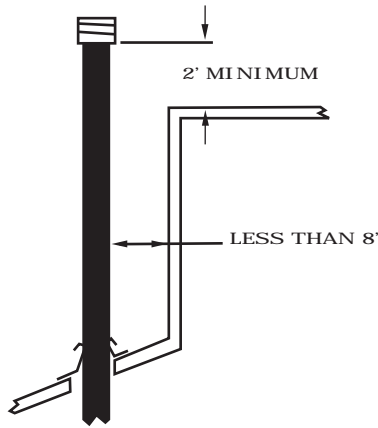

E. Firestops

1. Firestops are to be installed at each floor or ceiling level where vertical pipe passes through. At point where vent passes through floor or ceiling, opening should be framed to provide proper clearance to combustibles.
2. Use a piece of sheet metal which has been cut to fit framing and pipe and fasten to top of joist and framing member to eliminate any pockets in which combustible material may collect. (See Illustration 3)

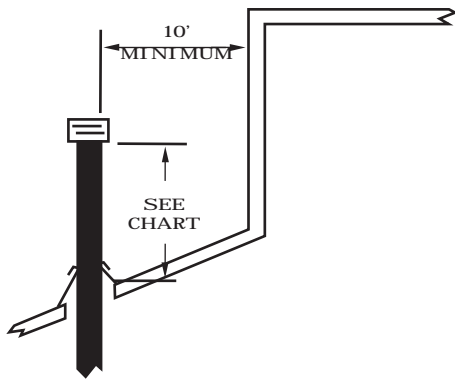

Illustration 5

NOTE:

1. 3" through 8" sizes must have 1" clearance to combustibles
2. 9" through 24" sizes must have 1 1/2" clearance to combustibles

IV. EXTERIOR VENTS

- A. Exterior vents are not recommended particularly in severe climates. If it is necessary to make this type of installation, use Mitchell Metal Vent Pipe in order to avoid rapid cooling of gases.
- B. A capped tee should be used at the base of the riser on a support, and vent should be securely fastened to wall with metal straps or perforated band iron, making sure to maintain proper clearance to combustibles.

V. VENTING TWO OR MORE APPLIANCES

- A. Whenever possible, a separate vent for each appliance should be run up through the roof. However, where this is not possible, they may be connected to a common vent.

B. When a combined vent is used, arrange individual vents to run vertically through ceiling with lateral runs connected in attic. Lateral runs connected to the common vent should be connected at the same point. When a combined vent is used, the common vent area shall be no less than the area of the largest vent plus 50% of the area of the additional vent. This rule may be used unless local codes state otherwise. (See Illustration 4)

VI. POSTING NOTICES

The posting of notices near the point where connection is made to the gas vent or roof jack, concerning limitations to use with gas appliances only.

VII. ROOF PITCH CHART

ROOF PITCH MINIMUM HEIGHT FROM ROOF TO LOWEST DISCHARGE OPENING

FLAT to 7/12	1'0"	(0.31 m)
OVER 7/12 TO 8/12	1'6"	(0.38 m)
OVER 8/12 TO 9/12	2'0"	(0.61 m)
OVER 9/12 TO 10/12	2'6"	(0.76 m)
OVER 10/12 TO 11/12	3'3"	(0.99 m)
OVER 11/12 TO 12/12	4'0"	(1.22 m)
OVER 12/12 TO 14/12	5'0"	(1.52 m)
OVER 14/12 TO 16/12	6'0"	(1.83 m)
OVER 16/12 TO 18/12	7'0"	(2.13 m)
OVER 18/12 TO 20/12	7'6"	(2.29 m)
OVER 20/12 TO 21/12	8'0"	(2.44 m)

For installations other than covered by the table above, or closer than 8 feet (2.44 m) to any vertical wall, the cap shall be not less than 2 feet (0.61 m) above the highest point where the gas vent passes through the roof and at least 2 feet higher than any portion of a building within 10 feet (3.05 m).

NOTE:

- 1. 3" through 8" sizes must have 1" clearance to combustibles**
- 2. 9" through 24" sizes must have 1½" clearance to combustibles**

For installations of caps 14" and larger, the cap is to be located no less than 2 feet above the highest point where the vent passes through the roof and at least 2 feet higher than any portion of a building within 10 feet.

**MITCHELL METAL PRODUCTS
MITCH FLEX - VENT
INSTALLATION INSTRUCTIONS**

Mitchell Metal Products, Inc. Mitch Flex - Vent Single Wall Gas Connector is to be used as a connector for venting listed Draft - hood equipped gas appliances or other appliances listed for use with Type B Gas Vent. They are not to be used with incinerators and solid or liquid fuel burning appliances.

Mitchell Metal Products, Inc. Mitch Flex - Vent Single Wall Gas Connectors are manufactured in round sizes 3" through 5" and are to be connected with single or multiple appliances with a 1" clearance to combustibles.

MITCHELL METAL PRODUCTS, INC. MITCH FLEX-VENT IS NOT TO BE ENCLOSED OR USED AS A TYPE B GAS VENT. IT IS ONLY A GAS CONNECTOR AND IT IS NOT TO BE USED TO PASS THROUGH WALLS, FLOORS, OR CEILINGS. IT IS NOT TO BE USED IN ATTICS OR CRAWL SPACES.

Mitchell Metal Products, Inc. Mitch Flex - Vent Gas Connector is listed with Underwriters Laboratories and was tested to U.L. Standard 1738. Install connectors individually or in multiples when properly sized. Refer to the Appliance Manufacturer's Installation Instructions and the National Fuel Gas Code NFPA 54.

GENERAL INSTALLATION INSTRUCTIONS:

1. Gas connectors are to be sized and installed according to the gas appliance instructions and in accordance with all applicable building codes.
2. Gas connectors are not to be cut or changed in any way. The gas connector can be compressed to fit all applications. Compressing the connector will not affect the venting performance.
3. Gas connectors are to be used in any installation where single wall gas vent connectors are acceptable. The minimum clearance to combustibles may be reduced from 6" to 1" in an open installation.
4. Install all gas connectors properly making sure that:
 - A. All runs are straight and short
 - B. All bends are not greater than 90 degrees
 - C. If necessary, all runs will be supported by vent hangers to eliminate sags in the connector
 - D. Rise in the connectors is at least 1/4" per foot
 - E. Clearances from combustibles in an open installation is at least 1"

TO CONNECT THE GAS CONNECTOR TO A GAS FIRED APPLIANCE MAKE SURE THAT:

1. Gas vent connector is properly secured to the gas appliance by using a Mitchell Metal Products, Inc. flex vent appliance connector. The Mitchell Metal Products, Inc. gas vent connector twist locks into place. The use of sheet metal screws is necessary only when connecting to the appliance draft hood, outlet collar, wye, or tee. Do not use any alternate aluminum flex duct material as a connector.
2. Type B gas vent to which the gas connector will be attached must be securely mounted and extended into the appliance room where it will engage the gas connector. Remember, gas connector cannot pass through walls or ceilings.
3. Gas connector can also be attached to a Type B gas vent by means of a tee and a tee cap, or a wye and a tee cap.
4. Remember to maintain as straight a run as possible. Use one support bracket every 5 feet along the length of the flexible gas vent connector unless it is fixed to the appliance outlet or Type B gas vent.
5. For Multiple Appliances, make sure that the vent is properly sized to accommodate the appliances through one vent. Once the proper Type B gas vent has been installed and secured, attach the gas connectors to the appliances and the connectors to the gas vent by means of tees and wyes. Please refer to Illustrations A & B.

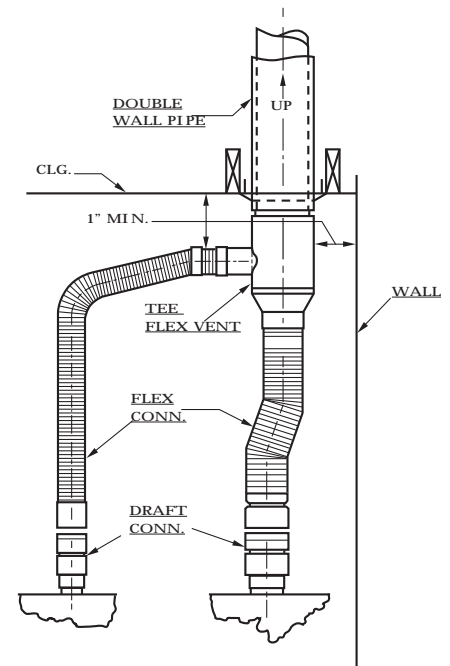
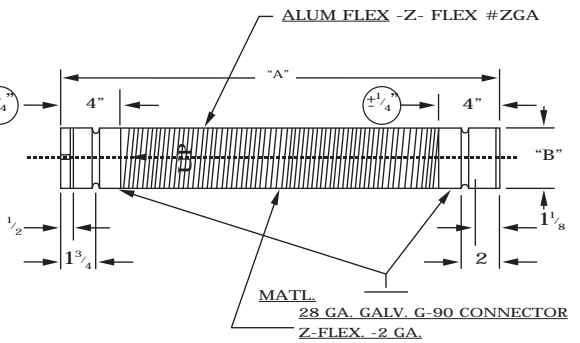

Illustration A

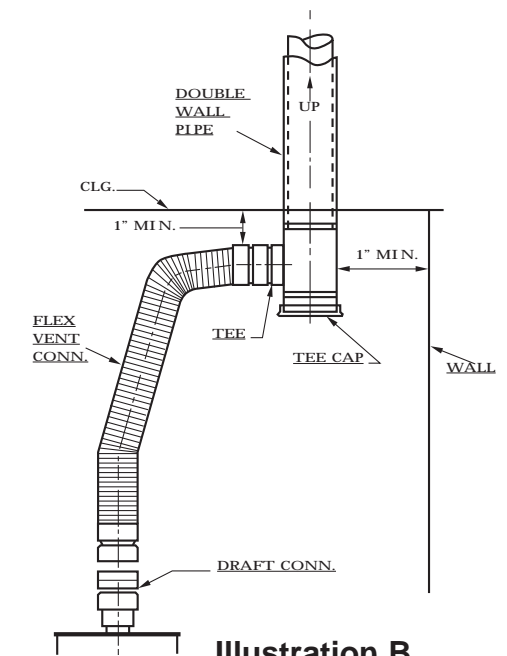

Illustration B

