



**POLAR TEMP ICE MERCHANDISER
INSTALLATION, OPERATION, &
MAINTENANCE MANUAL**

www.polartemp.com



TABLE OF CONTENTS

Disclaimer	Page 3
Inspection and unpacking	Page 4
Installation	Page 4
Before Operation	Page 5
Operation	Page 5 - 9
<ul style="list-style-type: none"> ● Electrical ● Temperature Control – Cold Wall, Automatic Defrost, Electronic Automatic Defrost ● Load with Bagged Ice 	
Maintenance	Page 9 - 10
<ul style="list-style-type: none"> ● Refrigeration <ul style="list-style-type: none"> ● Defrosting <ul style="list-style-type: none"> ● Cold Wall (CW) ● Auto Defrost (AD) ● Doors <ul style="list-style-type: none"> ● Gaskets ● Hinges ● Finish 	
Cold Wall Wiring Diagram – Mechanical Controls	Page 11
Automatic Defrost Wiring Diagram – Mechanical Controls	Page 12
Automatic Defrost Wiring Diagram w/ ETC-1H Electronic Control	Page 13
Automatic Defrost Wiring Diagram w/ERC102C Electronic Control	Page 14
Cold Wall Wiring Diagram w/ERC101A Electronic Control	Page 15
Automatic Defrost Trouble Shooting Guide	Page 16 - 17
Cold Wall Troubleshooting Guide	Page 18
Refrigeration and Electrical Diagnostic Guide	Page 19 - 23
Refrigeration Data and Specifications	Page 24 - 26
Policy Statement	Page 27 - 28
<ul style="list-style-type: none"> ● Warranty ● Parts Orders ● Method of Shipment ● Ship Dates ● Return of Merchandise ● Pricing ● Ordering addresses, telephone numbers and websites 	
Factory Sales Locations	Page 29

DISCLAIMER

Polar Temp is committed to continuous material and product improvements. This manual is subject to modification without notice without incurring responsibility for previously sold merchandisers and components.

Thank you for purchasing from Polar Temp.

INSPECTION AND UNPACKING:

Polar Temp merchandisers are individually inspected and carefully packaged to ensure each unit arrives without damage.

- Upon receipt, **immediately inspect** the merchandiser for any evidence of shipping damage **while the delivery truck driver is there**. If the merchandiser is damaged, **document damage on the bill of lading** and give the driver a copy. Notify the delivering carrier immediately and request a damage inspection and claim. Polar Temp is not responsible for damage to merchandisers during transit. A merchandiser damaged in transit is the delivering carrier's responsibility.
- Remove plastic stretch wrap and merchandiser corner protectors. The wooden skid is removed by cutting the metal band under the skid.
- The merchandiser should be moved in an upright position. If the merchandiser is tilted past 45 degrees, it is recommended that it not be used for a time equal to the time it was tilted. This will allow the compressor lubricant to drain back to normal position.

INSTALLATION:

Install the merchandiser for customer convenience, easy access and maximum exposure. The location must provide good ventilation for the refrigeration system. **DO NOT BLOCK AIRFLOW TO THE CONDENSING UNIT.**

- Outdoor merchandisers should be placed on a flat, level surface allowing water drainage away from merchandiser. The surface should also be strong enough to support the merchandiser with a load of ice. Be sure to check the load capacity of the merchandiser prior to installation. If the merchandiser is not level, the self-closing doors on upright models may not close or seal properly.
- It is essential that auto-defrost models be placed on a level surface to allow defrost water to drain properly. If defrost water does not drain, it will freeze in the drain pan which can eventually cause the fans to seize.
- Auto-defrost models should be installed leaving sufficient distance behind the merchandiser to prevent the evaporator drain hose from being kinked or hose opening from being obstructed.
- Auto-defrost models with a condensate evaporator on the back should not be placed directly against or touching a wall.

- Adequate space should be allowed around the exterior walls of the merchandisers to allow for evaporation of any condensation that may occur on cabinet exterior.
- Outdoor merchandisers should be located in a shaded area away from direct sunlight for the most economical operation.
- A minimum 115 Volt, 15 Amp grounded power source should be provided within a range of the power cord. **DO NOT USE EXTENSION CORDS.**

BEFORE OPERATION:

Glass Door Models:

- Some glass door models have support brackets that need to be removed.

Auto-defrost Glass (ADG) Door Models:

- Install condensate evaporator unit on rear of cabinet. Screwdriver is required.

OPERATION:

Electrical:

The electrical power supplied to the merchandiser must be as identified on the serial number data plate located on the inside of the merchandiser. Electrical service connections must be in accordance with the National Electrical Code, state code and any local codes that may apply. All merchandisers are equipped with a power cord and a 3-prong plug. **WARNING: Improper use or removal of the grounding plug can result in a risk of electric shock!**

Be sure to use a grounded electrical receptacle with a fused circuit sized correctly for the electrical load. **Do not use extension cords.** Extension cords may decrease the voltage to the unit and ultimately cause the compressor or other component failure. The merchandiser data plate indicates the recommended maximum over current protective device size.

Note: Some outdoor locations require ground fault interrupt (GFI) outlets. These outlets may trip upon condensing unit start. Refrigeration equipment is exempt in some areas from GFI requirements. Local electric codes should be checked.

Start Up:

Plug merchandiser power cord into lower receptacle of electrical outlet. The condensing unit will start immediately (electronically controlled models have a delay on start up) and the unit cooler evaporator fans will start on the auto-defrost models. The condensing unit will continue to run until air temperature inside the merchandiser reaches 10° F and then cycle on and off between 10° F and 20° F.

If the merchandiser has a condensate evaporator, plug the power cord from it into the upper receptacle of electrical outlet.

Mechanical Temperature Control:

Automatic Defrost Models Previous to November 2010

Merchandiser temperature is maintained by a mechanical thermostat that cycles the condensing unit on and off automatically. On auto-defrost (AD) models, the temperature control is located on the left end of the evaporator blower coil assembly. On cold wall models, the control is located on a bracket under the condensing unit cover.

The temperature is adjusted by turning the thermostat control knob clock-wise for colder temperature and counter-clockwise for warmer temperatures. Turning the control knob fully counter-clockwise will shut power off to the compressor. **DO NOT** re-adjust the internal adjustments of the thermostat without consulting Polar Temp.

Electronic Temperature Control:

Automatic Defrost Models – ETC-1H November 2010 to March 2012

Merchandiser temperature is maintained by an electronic thermostat that cycles the condensing unit on and off automatically. On auto-defrost (AD) models, the temperature control is located on the left end under the hood on outdoor units and to the left of the condensing unit on indoor skirt hood models.

Minimal temperature adjustment (2 degrees F min/max adjustment) is possible by turning the thermostat control knob clock-wise for colder temperature and counter-clockwise for warmer temperatures since the electronic control is pre-set at the factory. **DO NOT** adjust the thermostat without consulting Polar Temp.

The electronic control is factory set with a computer at the factory therefore there is no need to make field adjustments. The digital display on your new Polar Temp Ice Merchandiser will show fault codes and other information as described below:

“E1” on the digital display means “faulty air sensor”

“E2” on the digital display means “faulty defrost sensor”

“---“ on the digital display means the refrigeration system has been “turned off”

“def” on the digital display means the refrigeration system is in “defrost cycle”

“E13” on the digital display means “communication error” (cable between the digital readout and the control relay is faulty)

Electronic Temperature Control: (continued)
Automatic Defrost Models
November 2010 to March 2012

“VH” indicates “voltage high”
“VL” indicates “voltage low”

Two buttons on the digital display will do the following:

Pressing both buttons at the same time for 10 seconds will shut the refrigeration system “OFF” (“---“ shown on the digital display)

Pressing the top button for 10 seconds will give you the option of temperature display in centigrade (C°) or Fahrenheit (F°)

Pressing the bottom button for 10 seconds will put the refrigeration system into a manual defrost (“def” shown on the digital display) The system will automatically return to refrigeration cycle after temperature 50° F or 15 to 20 minutes is satisfied, whichever comes first. The system will go into defrost every 60 minutes of “compressor” run time.

If the electrical power supply is interrupted the electronic control will always start automatically after a short delay in a new refrigeration cycle.

Electronic Temperature Control:

Automatic Defrost Models – ERC102C
Starting March 2012

Merchandiser temperature is maintained by an electronic thermostat that cycles the condensing unit on and off automatically. On auto-defrost (AD) models, the electronic temperature control is located on the left end under the hood on outdoor units and to the left of the condensing unit on indoor skirt hood models.

Minimal temperature adjustment (5 degrees F min/max adjustment) is possible by pressing the up or down arrow buttons for colder or warmer temperatures since the electronic control is pre-set at the factory. **DO NOT** adjust the thermostat without consulting Polar Temp.

The electronic control is factory set with a computer at the factory therefore there is no need to make field adjustments. The digital display on your new Polar Temp Ice Merchandiser will show fault codes and other information as described below:

“E01” on the digital display means “faulty air sensor”

“E02” on the digital display means “faulty defrost sensor”
“E03” when used is faulty “condenser air sensor”
“OFF“ on the digital display means the refrigeration system has been “turned off”
“ON“ on the digital display means the refrigeration system has been “turned on”
“def” on the digital display means the refrigeration system is in “defrost cycle”
“VH” indicates “voltage high”
“VL” indicates “voltage low”

The four buttons on the digital display will do the following:

Pressing the bottom left hand button approximately 10 seconds (“OFF or ON“ will show on the digital display)

Pressing the top left hand button approximately 10 seconds will put the system into defrost mode (“def” will show on the digital display) The system will automatically return to refrigeration cycle after coil defrost temperature reaches 55° F or 15 to 20 minutes is satisfied, whichever comes first. The system will go into defrost every 60 minutes of “compressor” run time.

If the electrical power supply is interrupted the electronic control will always start automatically in the refrigeration cycle after a short delay.

Electronic Temperature Control:

Cold Wall Models – ERC101A Starting May 2012

Merchandiser temperature is maintained by an electronic thermostat that cycles the condensing unit on and off automatically. On cold-wall (CW) models, the electronic temperature control is located on the left end under the hood on outdoor units and to the left of the condensing unit on indoor skirt hood models.

Minimal temperature adjustment (5 degrees F min/max adjustment) is possible by pressing the up or down arrow buttons for colder or warmer temperatures since the electronic control is pre-set at the factory. **DO NOT** adjust the thermostat without consulting Polar Temp.

The electronic control is factory set with a computer at the factory therefore there is no need to make field adjustments. The digital display on your new Polar Temp Ice Merchandiser will show fault codes and other information as described below:

“E01” on the digital display means “faulty air sensor”
“E03” when used is faulty “condenser air sensor”
“OFF“ on the digital display means the refrigeration system has been “turned off”

“ON“ on the digital display means the refrigeration system has been “turned on”
“VH” indicates “voltage high”
“VL” indicates “voltage low”

Four buttons on the digital display will do the following:

The four buttons on the digital display will do the following:

Pressing the bottom left hand button approximately 10 seconds (“OFF or ON“ will show on the digital display)

Pressing the top left hand button approximately 10 seconds will put the system into defrost mode (“def” will show on the digital display) The system will automatically return to refrigeration cycle after temperature 55° F or 15 to 20 minutes is satisfied, whichever comes first. The system will go into defrost every 60 minutes of “compressor” run time.

If the electrical power supply is interrupted the electronic control will always start automatically after a short delay in a new refrigeration cycle.

Loading merchandiser with bagged ice:

After the merchandiser is operating at required temperature, load it with bagged ice. Bagged ice should not be stacked such that it will obstruct air flow in automatic defrost blower coil merchandisers.

Cold wall glass door units should have ice stacked to allow open-air access to thermostat sensor at upper rear interior. Approximately 3” needs to be clear from top of stacked ice to top of inside interior for effective refrigeration and ice storage.

MAINTENANCE:

Refrigeration: WARNING – disconnect electrical power before cleaning.

Clean refrigeration cover grill openings, condenser fins, and condenser fan blades at least two (2) times per year, more often if needed. A dirty condenser will cause the merchandiser to become less efficient, and may lead to compressor failure.

Clean the evaporator coil and fan blades on auto-defrost merchandisers as required.

- Clean condenser coil fins with a fine bristle brush or vacuum
- Routinely check wiring harness for loose connections or broken insulation

Defrosting: Frost cannot be avoided. It develops from moist air entering the merchandiser when the door is opened and forms on the evaporator. When the frost accumulation on the evaporator becomes too heavy, it acts as an insulator, which hinders the refrigeration efficiency.

- Excess frost or water on the interior of the merchandiser should be removed or drained. Do not allow water to stand in or around the cabinet.

Cold Wall (CW): Cold Wall type merchandisers utilize the merchandiser's interior wall surface as the refrigeration evaporator. Frost accumulation will occur on all wall surfaces. The merchandiser can be defrosted by conventional methods using a wooden paddle or plastic scraper. Care must be exercised to prevent damaging piping and control parts. **Do not** use a sharp instrument to "chop" the frost from the interior surface as you may do irreparable damage. Remove the floor drain plug to allow water to drain.

Auto-Defrost (AD): Auto-Defrost (sometimes referred to as "electric defrost") type merchandisers utilize a cooler evaporator with an electric defrost heating element to melt the frost off the evaporator coil. The defrost cycle is controlled by the electronic control system which energizes the electric defrost heating element. The electronic control is located in the condensing unit compartment. The control is programmed to periodically place the system in a defrost cycle automatically every four hour of compressor run time. The length of the defrost cycle is approximately 14 to 16 minutes or 55 degrees at the coil, whichever comes first. The control used is non-adjustable, however, defrost button may be pushed to start a manual defrost cycle. If your merchandiser has the electronic defrost timer, part number AT1032-1 (not the electronic control system) you may turn the refrigeration system "OFF" with the toggle switch or unplug the wall plug, then turn it back to the "ON" position which will automatically start a manually induced defrost cycle.

Doors: Gaskets should be checked for tears or any other problems that would cause loss of seal. Replace torn/worn gaskets to maintain correct temperature and refrigeration efficiency.

Hinges exposed to harsh environmental conditions may require a lubricant for ease of operation. Spray light penetrating oil on the spring loaded hinge cartridge to extend the hinge life.

Finish: Schedule periodic cleaning of merchandiser interior and exterior. The cabinet can be cleaned with a mild detergent and water. **DO NOT USE** strong detergents, abrasive cleaners, or solvents, likely to leave objectionable odors which may be absorbed by the ice. Do not use wax or polish on the interior for the same reason. Wash exterior surfaces with a mild soap and warm water applied with a soft sponge or cloth. Wax exterior to maintain appearance and to protect the finish.

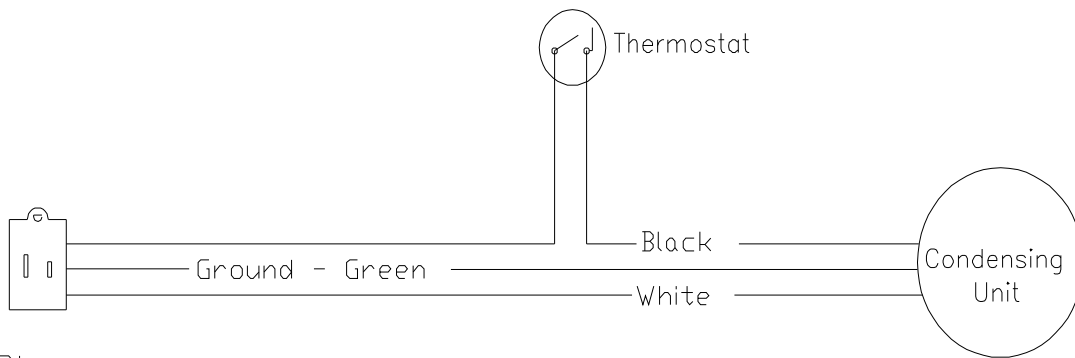

Plug
 110 Volt 60
 Hertz 1
 Phase

Wirng Diagram
 Cold Wall Merchandiser
 Part Number 0000835
 BLD 02-06-04

Mechanical Controls

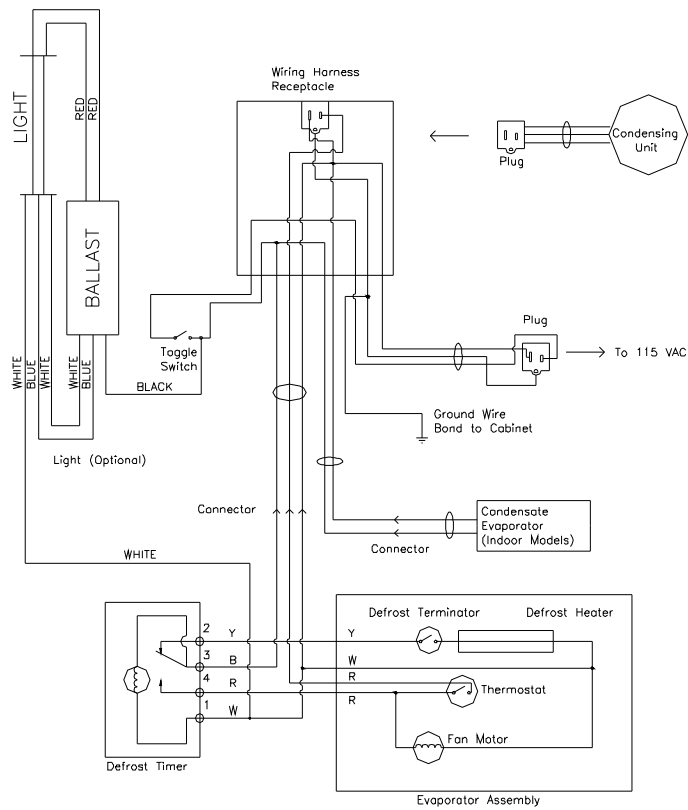

Wiring For Automatic Defrost Units

Polar Temp Drawing Number 0000554
 Revised 12-10-03 by Steve Krieger
 Revised 02-06-04 BLD Light Option added

Mechanical Controls

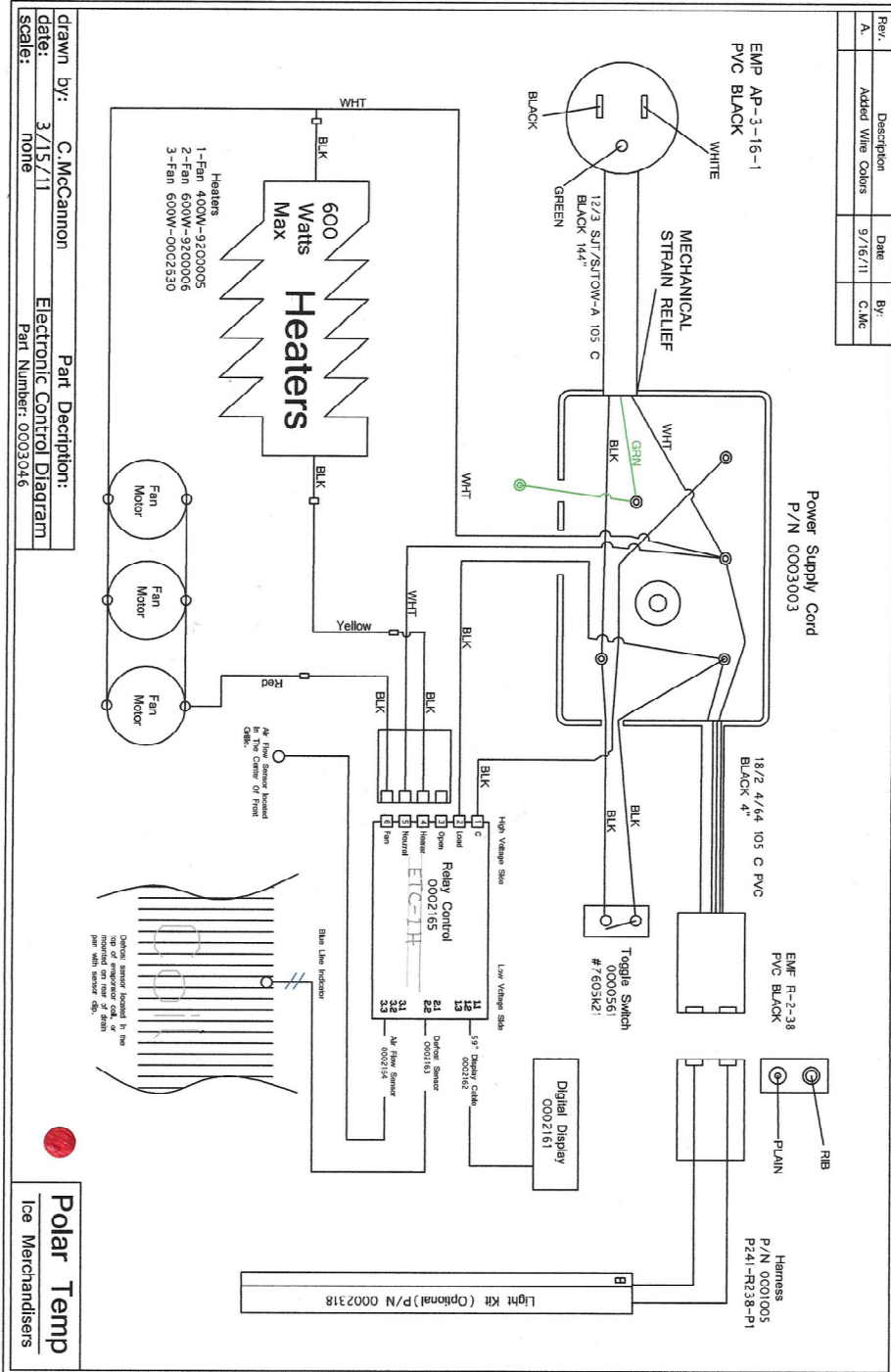

Drawn by: C. McCannan
 Date: 3/15/11
 Scale: none

Part Description: Electronic Control Diagram
 Part Number: 0003046

Polar Temp
 Ice Merchandisers

Electronic ETC-1H Control Auto Defrost

Polar Temp
 A Southeast Cooler Corporation Company
 Installation, Operation & Maintenance Manual Part Number 0000545
 Revisions 2/2/05, 01/06/11, 06/08/11, 05/18/12

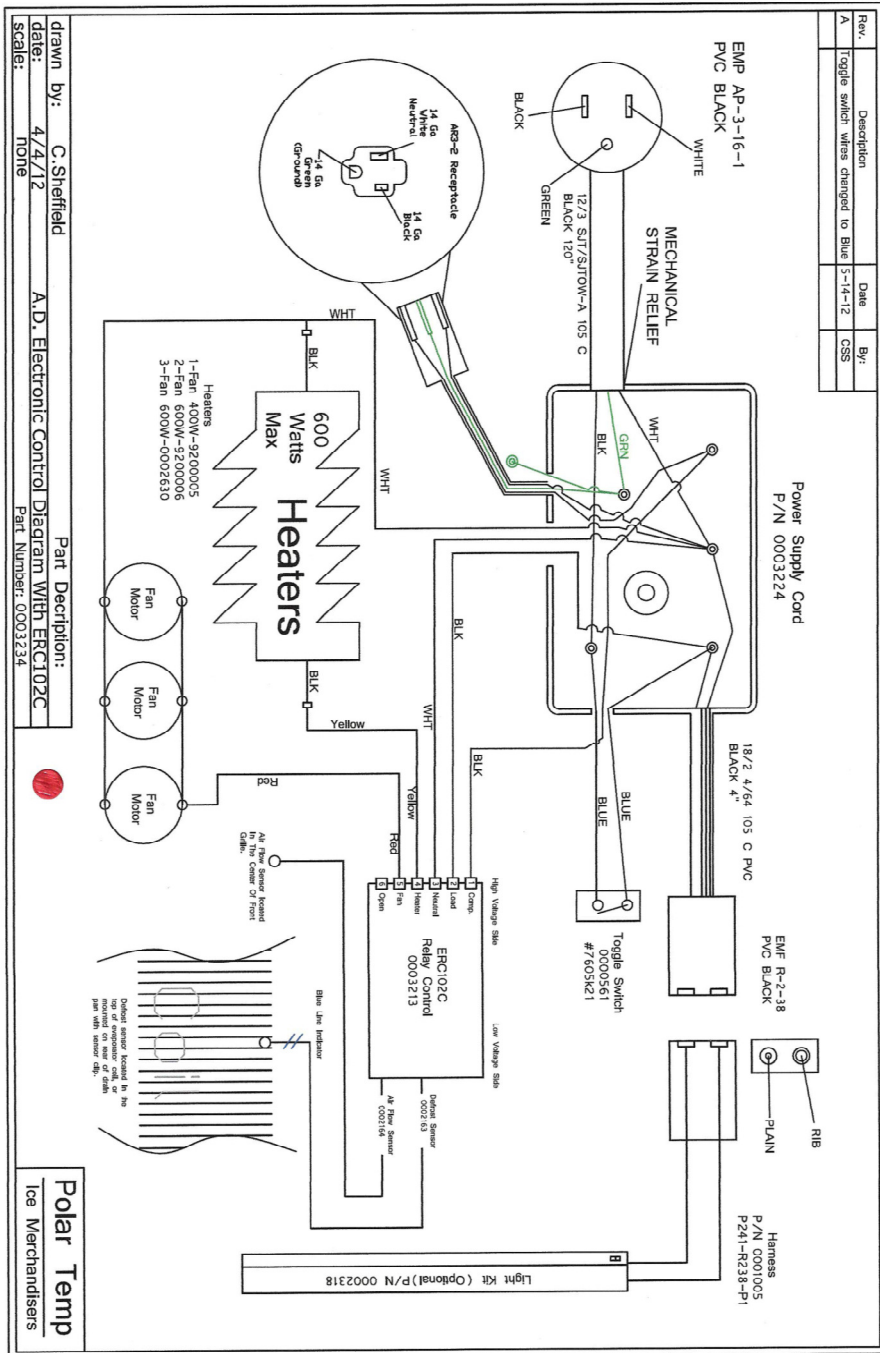

drawn by: C. Sheffield
 date: 4/4/12
 scale: none

Part Description:
 A.D. Electronic Control Diagram With ERC102C
 Part Number: 0003234

Polar Temp
Ice Merchandisers

Electronic ERC102C Control Auto Defrost

Polar Temp
 A Southeast Cooler Corporation Company
 Installation, Operation & Maintenance Manual Part Number 0000545
 Revisions 2/2/05, 01/06/11, 06/08/11, 05/18/12

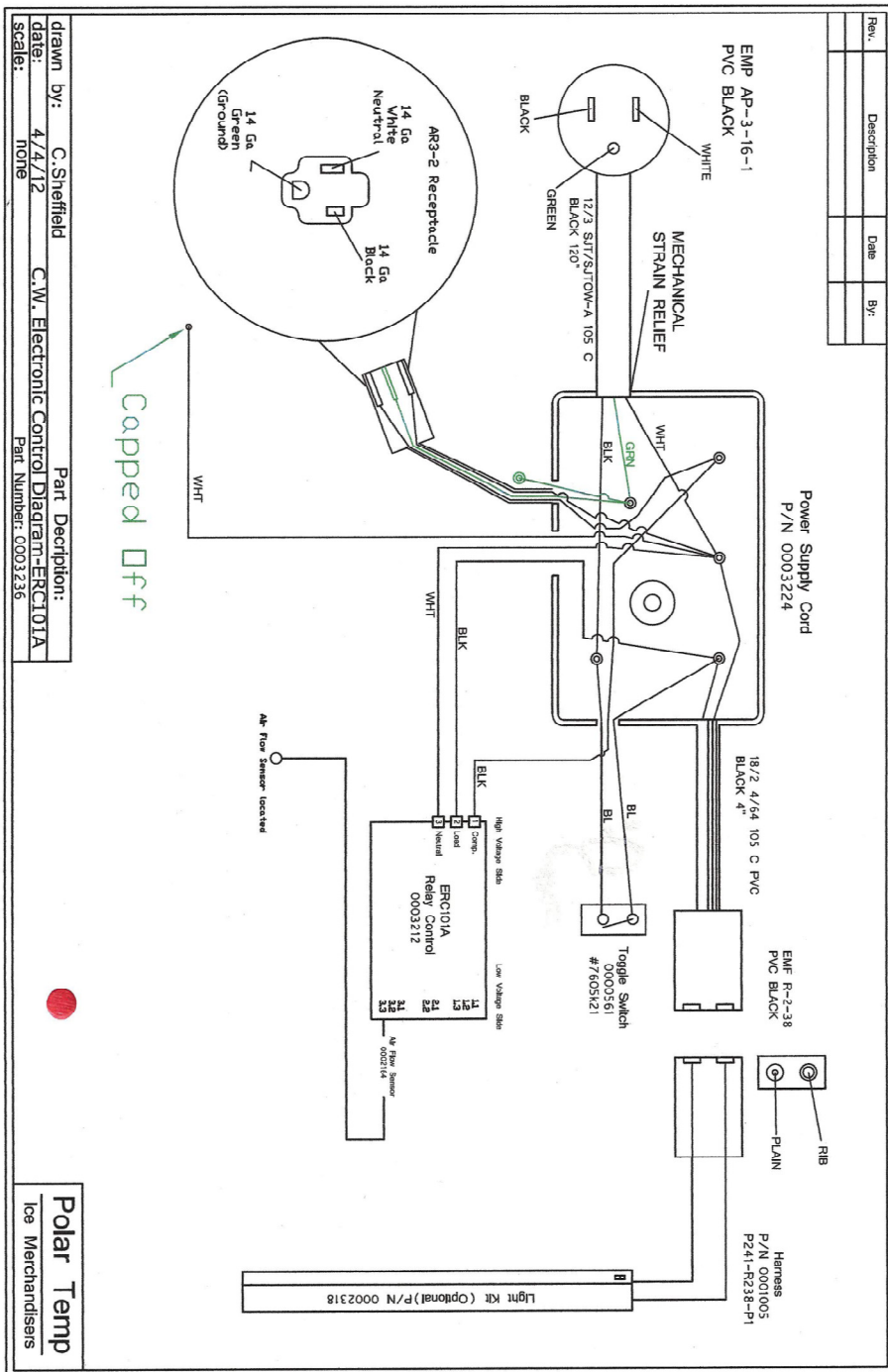

Electronic ERC101A Control Cold Wall

Polar Temp
 A Southeast Cooler Corporation Company
 Installation, Operation & Maintenance Manual Part Number 0000545
 Revisions 2/2/05, 01/06/11, 06/08/11, 05/18/12

AUTOMATIC DEFROST TROUBLE SHOOTING GUIDE

If refrigerant valves must be opened, a qualified technician should be notified to perform the work.

<u>Problem</u>	<u>Possible Cause</u>	<u>Solution</u>
Ice is melting	Power switch is in OFF position	Turn switch to ON position.
	Ice bags are blocking air flow	Move ice bags accordingly.
	Thermostat setting	Normal setting is between 4 and 6 on the dial. Jump terminals on thermostat to check, if unit starts, replace thermostat.
	Evaporator fan motors are operating but the fan blade not turning	Check to see if fan blade is slipping on the motor shaft.
	Condenser coil is dirty	Clean condenser.
	Incorrect refrigerant charge	Check sight glass when used for bubbles indicating wrong charge. Add refrigerant. Locate refrigerant leak.
	Condenser fan motor and compressor are not running	Check power supply. Check if defrost timer(mechanical controls) is stuck in defrost mode Check if compressor is hot, this may indicate that condenser fan motor has failed causing thermal overload on compressor to trip.
	Condenser fan motor is not operating	Check electrical power to motor.
	Compressor is not operating	Check electrical power, relay, overload protector, start capacitor and compressor motor.

AUTOMATIC DEFROST TROUBLESHOOTING GUIDE - continued

<u>Problem</u>	<u>Possible Cause</u>	<u>Solution</u>
Ice is melting	Evaporator fan motor not running	Check power supply to motor Check for faulty fan motor
	Check for ice build-up on the evaporator coil	Check power to defrost heater Check defrost heater for heat Check defrost termination thermostat Check defrost timer

COLD WALL TROUBLESHOOTING GUIDE

If refrigerant valves must be opened, a qualified technician should be notified to perform the work.

<u>Problem</u>	<u>Possible Cause</u>	<u>Solution</u>
Ice is melting	Power switch is in OFF position	Turn switch to ON position
	Thermostat setting	Thermostat should be set between 4 & 6
	Condenser coil is dirty	Clean condenser
	Incorrect refrigerant charge	Check sight glass when used for bubbles indicating wrong charge. Add refrigerant. Locate refrigerant leak.
	Condenser fan motor and compressor are not running	Check power supply. Check if thermostat has failed. Check if compressor is hot which may indicate that the condenser fan motor has failed causing the thermal overload in the compressor to trip.
	Condenser fan motor is not operating	Check electrical power to motor
	Compressor is not operating	Check electrical power to compressor. Check relay, overload protector and start capacitor. Check compressor motor.
	Check refrigerant charge	Adjust if necessary

REFRIGERATION and ELECTRICAL DIAGNOSTIC GUIDE

<u>Problem</u>	<u>Possible Cause</u>	<u>Solution</u>
Compressor will not start (no hum)	Be sure power is being supplied to the merchandiser	Check power cord Check plug in Check breaker switch
	Ambient colder than thermostat setting	Adjust thermostat if necessary
	Unit is in defrost	Allow defrost cycle to complete, usually 15-20 minutes, or turn manual control on defrost
	Overload protector stuck in open position	Replace overload protector
	Thermostat stuck in open position	Replace thermostat
	Wiring improper or loose	Check actual wiring against diagram
Compressor will not start (hums, but trips on overload protector)	Improperly wired	Check actual wiring against diagram
	Low voltage to unit	Check power supply. Contact Power Company
	Starting capacitor defective	Replace start capacitor
	Relay failing to close	Determine reason and correct or replace

REFRIGERATION and ELECTRICAL DIAGNOSTIC GUIDE - continued

<u>Problem</u>	<u>Possible Cause</u>	<u>Solution</u>
Compressor will not start (hums, but trips on overload protector)	Compressor motor has a winding open or shorted	Replace compressor
	Internal mechanical trouble in compressor	Replace compressor
Compressor starts, but does not switch off of start winding	Improperly wired	Check wiring against diagram
	Low voltage to unit	Determine reason and correct
	Relay failing to open	Determine reason and correct or replace
	Compressor motor has a winding open or shorted	Replace compressor
	Internal mechanical trouble in compressor	Replace compressor

REFRIGERATION and ELECTRICAL DIAGNOSTIC GUIDE - continued

<u>Problem</u>	<u>Possible Cause</u>	<u>Solution</u>
Compressor starts and runs, but short cycles on overload protector	Low line voltage to unit	Check power supply Contact Electric Company
	Overload protector defective	Replace overload protector
	Starting capacitor defective	Replace start capacitor
	Excessive discharge pressure	Check ventilation, restrictions in cooling medium, restrictions in refrigeration system
	Compressor too hot - return gas hot	Check refrigerant charge (fix leak) add refrigerant if necessary
	Compressor motor has a winding shorted	Replace compressor
Compressor runs a long time or continuous	Dirty condenser	Clean condenser
	Refrigerated space has excessive load.	Reduce load. Check for open door or bad door gasket.
	Evaporator coil iced	Defrost
	Thermostat contacts stuck in closed position	Replace thermostat
	Shortage of refrigerant	Fix leak, add charge

REFRIGERATION and ELECTRICAL DIAGNOSTIC GUIDE - continued

<u>Problem</u>	<u>Possible Cause</u>	<u>Solution</u>
Starting Capacitor open	Relay contacts not closing	Replace relay
	Prolonged operation on start cycle due to low line voltage	Determine reason and correct
	Prolonged operation on start cycle due to improper relay	Replace relay
	Excessive short cycling (Compressor starts and runs for a short cycle)	See "Compressor starts and runs, but short cycles on overload protector" section
Relay defective or burned out	Line voltage too high or too low	Determine reason and correct
	Excessive short cycling	Determine reason and correct (see Compressor starts and runs but short Short cycles)
	Relay being influenced by loose vibrating mounting	Remount relay rigidly

REFRIGERATION and ELECTRICAL DIAGNOSTIC GUIDE - continued

<u>Problem</u>	<u>Possible Cause</u>	<u>Solution</u>
Warm refrigerated storage space	Thermostat setting too high	Adjust thermostat
	Inadequate air circulation	Improve air circulation
Suction line frosted	Evaporator fan not running	Determine reason and correct
	Overcharge of refrigerant	Correct charge
Liquid line frosted	Restriction in drier	Replace drier
Condensing unit noisy	Loose parts or mountings	Find and tighten
	Tubing rattle	Apply sponge rubber between parts (Armaflex)
	Bent fan blade causing vibrations	Replace blade
	Fan motor bearings worn	Replace motor

**POLAR TEMP ICE MERCHANDISER
REFRIGERATION DATA AND SPECIFICATIONS**
R404A system Electronic Temperature Controlled Automatic Defrost System

Also available for use in high ambient conditions except 3/4 HP systems.

* Actual minimum amp draw may vary.

Model	HP	Condensing Unit	Coil	Cap Tube	Defrost Heater	Refrigerant Type	Charge Ounces	Min. Amps*	Volts	Max. Amps
300AD	1/4	119-2022	1 fan	.036" x 72"	400W	404A	12.5	5.8	115V	15
300ADG	1/4	119-2022	1 fan	.036" x 72"	400W	404A	12.5	5.8	115V	15
380AD	1/4	119-2022	1 fan	.036" x 72"	400W	404A	12.5	5.8	115V	15
400AD	1/3	119-2027	2 fan	.042" x 74"	600W	404A	13.5	7.0	115V	15
420AD	1/4	119-2022	1 fan	.036" x 72"	400W	404A	12.5	6.4	115V	15
420ADG	1/4	119-2022	1 fan	.036" x 72"	400W	404A	12.5	6.4	115V	15
570AD	1/3	119-2027	3 fan	.042" x 74"	600W	404A	14.5	7.9	115V	15
600AD	1/3	119-2027	2 fan	.042" x 74"	600W	404A	15	7.6	115V	15
630AD	1/3	119-2027	2 fan	.042" x 74"	600W	404A	15	7.6	115V	15
630ADG	1/3	119-2027	2 fan	.042" x 74"	600W	404A	15	7.6	115V	15
650AD	1/3	119-2027	2 fan	.042" x 74"	600W	404A	15	7.6	115V	15
650ADG	1/3	119-2027	2 fan	.042" x 74"	600W	404A	15	7.6	115V	15
670AD	1/3	119-2027	2 fan	.042" x 74"	600W	404A	15	7.5	115V	15
670ADG	1/3	119-2027	2 fan	.042" x 74"	600W	404A	15	7.5	115V	15
850AD	1/2	119-2032	3 fan	.044" x 74"	600W	404A	18	10.3	115V	15
850ADG	1/2	119-2032	3 fan	.044" x 74"	600W	404A	18	10.3	115V	15
850AD	3/4	FJAF-0075	3 fan	TX Valve	600W	404A	21	18	115V	20
850ADG	3/4	FJAF-0075	3 fan	TX Valve	600W	404A	21	18	115V	20
1000AD	1/2	119-2032	3 fan	.044" x 74"	600W	404A	18	10.9	115V	15
1000ADG	1/2	119-2032	3 fan	.044" x 74"	600W	404A	21	10.9	115V	15
1000AD	3/4	FJAF-0075	3 fan	TX Valve	600W	404A	21	18	115V	20
1000ADG	3/4	FJAF-0075	3 fan	TX Valve	600W	404A	21	18	115V	20

**POLAR TEMP ICE MERCHANDISER
REFRIGERATION DATA AND SPECIFICATIONS**
R404A system Mechanically Controlled Automatic Defrost System

Also available for use in high ambient conditions except 3/4 HP systems.

* Actual minimum amp draw may vary.

Model	HP	Condensing Unit	Coil	Cap Tube	Defrost Heater	Refrigerant Type	Charge Ounces	Min. Amps*	Volts	Max. Amps
300AD	1/4	119-2022	1 fan	.036" x 72"	400W	404A	12.5	5.8	115V	15
300ADG	1/4	119-2022	1 fan	.036" x 72"	400W	404A	12.5	5.8	115V	15
380AD	1/4	119-2022	1 fan	.036" x 72"	400W	404A	12.5	5.8	115V	15
400AD	1/3	119-2027	2 fan	.042" x 74"	600W	404A	13.5	7.0	115V	15
420AD	1/4	119-2022	1 fan	.036" x 72"	400W	404A	12.5	6.4	115V	15
420ADG	1/4	119-2022	1 fan	.036" x 72"	400W	404A	12.5	6.4	115V	15
570AD	1/3	119-2027	3 fan	.042" x 74"	800W	404A	14.5	7.9	115V	15
600AD	1/3	119-2027	2 fan	.042" x 74"	600W	404A	15	7.6	115V	15
630AD	1/3	119-2027	2 fan	.042" x 74"	600W	404A	15	7.6	115V	15
630ADG	1/3	119-2027	2 fan	.042" x 74"	600W	404A	15	7.6	115V	15
650AD	1/3	119-2027	2 fan	.042" x 74"	600W	404A	15	7.6	115V	15
650ADG	1/3	119-2027	2 fan	.042" x 74"	600W	404A	15	7.6	115V	15
670AD	1/3	119-2027	2 fan	.042" x 74"	600W	404A	15	7.5	115V	15
670ADG	1/3	119-2027	2 fan	.042" x 74"	600W	404A	15	7.5	115V	15
850AD	1/2	119-2032	3 fan	.044" x 74"	800W	404A	18	10.3	115V	15
850ADG	1/2	119-2032	3 fan	.044" x 74"	800W	404A	18	10.3	115V	15
850AD	3/4	FJAF-0075	3 fan	TX Valve	800W	404A	21	18	115V	20
850ADG	3/4	FJAF-0075	3 fan	TX Valve	800W	404A	21	18	115V	20
1000AD	1/2	119-2032	3 fan	.044" x 74"	800W	404A	18	10.9	115V	15
1000ADG	1/2	119-2032	3 fan	.044" x 74"	800W	404A	21	10.9	115V	15
1000AD	3/4	FJAF-0075	3 fan	TX Valve	800W	404A	21	18	115V	20
1000ADG	3/4	FJAF-0075	3 fan	TX Valve	800W	404A	21	18	115V	20

**POLAR TEMP ICE MERCHANDISER
REFRIGERATION DATA AND SPECIFICATIONS**

R404A system Cold Wall

Also available for use in high ambient conditions except 3/4 HP systems.

* Actual minimum amp draw may vary.

Model	HP	Condensing Unit	Cap Tube	Refrigerant Type	Charge Ounces	Min. Amps*	Volts	Max. Amps
300CW	1/4	119-2022	.036" x 72"	404A	12.5	5.2	115V	15
300CWG	1/4	119-2022	.036" x 72"	404A	12.5	5.2	115V	15
380CW	1/4	119-2022	.036" x 72"	404A	12.5	5.3	115V	15
400CW	1/3	119-2027	.042" x 74"	404A	13.5	5.4	115V	15
420CW	1/4	119-2022	.036" x 72"	404A	12.5	5.3	115V	15
420CWG	1/4	119-2022	.036" x 72"	404A	12.5	5.8	115V	15
570CW	1/3	119-2027	.042" x 74"	404A	12.5	7.3	115V	15
600CW	1/3	119-2027	.042" x 74"	404A	15	6.4	115V	15
630CW	1/3	119-2027	.042" x 74"	404A	15	7.3	115V	15
630CWG	1/3	119-2027	.042" x 74"	404A	15	7.3	115V	15
650CW	1/3	119-2027	.042" x 74"	404A	15	7.3	115V	15
650CWG	1/3	119-2027	.042" x 74"	404A	15	7.3	115V	15
670CW	1/3	119-2027	.042" x 74"	404A	15	7.4	115V	15
670CWG	1/3	119-2027	.042" x 74"	404A	15	7.4	115V	15
850CW	1/2	119-2032	.044" x 74"	404A	18	9.6	115V	15
850CWG	1/2	119-2032	.044" x 74"	404A	18	9.6	115V	15
850CW	3/4	FJAF-0075	.062" x 74"	404A	24	18	115V	20
850CWG	3/4	FJAF-0075	.062" x 74"	404A	24	18	115V	20
1000CW	1/2	119-2032	.044" x 74"	404A	20	10.9	115V	15
1000CWG	1/2	119-2032	.044" x 74"	404A	20	10.9	115V	15
1000CW	3/4	FJAF-0075	.062" x 74"	404A	24	18	115V	20
1000CWG	3/4	FJAF-0075	.062" x 74"	404A	24	18	115V	20

POLAR TEMP ICE MERCHANTISER POLICY

Warranty

Seller warrants the goods sold to be free from defects in materials and workmanship, under normal conditions and use for the following period of time:

Compressor – five (5) years from the original date of shipment

Merchandiser Parts – one (1) year from the original date of shipment

Labor – 60 days (Purchaser's authorized service technician must contact factory for approval).

This warranty applies to goods installed in the continental United States, Canada and the Caribbean Islands only. Seller's sole obligation under this warranty shall be limited to repair or replacement of any part or parts of said goods, F.O.B. Seller's factory which proves defective within the applicable warranty period. Seller reserves the right to inspect allegedly defective goods and to require the return, at the Buyer's expense, of goods for the purposes of inspection. This warranty shall not apply to any good, or any part thereof, which has been subject to any accidents or negligence or abuse of misuse, alteration or detrimentally affected its physical condition, use or operation qualities.

Parts Orders

Please order parts by Polar Temp part number as listed in the replacement parts catalog. Always have available the model and serial number of the cabinet, and in some cases the manufacturers name and model number of the part. In case of warranty replacement this information is required. Parts will not be issued as warranty or warranty authorized without this information.

Method of Shipment

Every shipment is carefully packed for domestic shipment and labeled to prevent damage or loss in transit. Specify where shipment should be sent, freight, express, parcel post, airfreight or united parcel. If no preference is given, or in case of freight shipment, the routing is not furnished, shipment will be made according to our discretion without liability of any kind on our part for each selection. We welcome your suggestions on preferred carriers for better service.

Common carrier shipments are forwarded freight collect. Under pre-approved circumstances, where transportation charges are prepaid, they will be added to the invoice. Please note that prepaid freight charges are subject to sales tax if a signed sales tax exemption certificate is not on file with Polar Temp. All UPS shipments will be prepaid and added to the invoice.

POLAR TEMP ICE MERCHANDISER POLICY

Ship Dates

Promise of delivery represents only our best estimate of the time required completing the work and shipping the product from our plant. Orders are accepted with the understanding that shipping dates are approximate and subject to change because of factory conditions, fires, supplier delays, material shortages, civil or military authority, mandatory priority and/or other causes beyond our knowledge or control.

Return Of Merchandise

No returned merchandise will be accepted without prior authorization from Polar Temp. When orders have been correctly filled, and merchandise is returned, a 10% handling charge plus reconditioning charges, if any, will be applied. No return shipment will be accepted unless authorized in advance and the freight is prepaid. During the warranty period, in order to obtain proper credit from our vendors, all defective parts must be returned within 45 days, freight prepaid to our factory for repair, replacement or credit.

Pricing

All prices listed are F.O.B. Lithia Springs, Georgia, and are subject to change without notice.

Ordering addresses, telephone numbers and websites

Sales Email – sales@polartemp.com

Corporate Sales – 1-877-984-5945

Polar Temp Factory Office – 770-819-1100

Polar Temp Website – www.polartemp.com

Corporate Website – www.secooler.com

FACTORY SALES LOCATIONS

Alcoa, TN 37701
1-877-984-5945

Center, TX
1-866-598-4206

Charlotte, NC
1-866-827-3232

Shafter, CA
1-866-746-0437

Buford, GA
1-800-554-4852

Colorado Springs, CO
1-877-376-0367