

UNIVERSAL PARTS MOTORS

MFG: Emerson MODEL: K55HXMTK-4411 MFG: _____ MODEL: _____

H. P. 1/2* RPM 1075 SPEEDS 3 VOLTS 115 PH 1 HZ 60 CAP 5, 7.5 or 10/370 @ 115V

F. L. AMPS 9.8 LR - ROTATION Rev (OSE) FRAME 48 THERMALLY PROTECTED Yes WIND. CLASS B

SHAFT 1/2" x 5" FLAT 4" MOTOR TYPE PSC STACK 2.25" BEARINGS Sleeve OIL See back of Instr

TORQUE: HI 63.0 OZ FT (BD) @ 950 RPM M/Hi 39.0 OZ FT (BD) LO 27.2 OZ FT (BD) @ 115 VOLT 5/370 CAP.

MOUNTING: THRU BOLT Yes SHELL BAND Yes SHELL HOLES No HUB RINGS No

SHAFT POSITION All SHAFT END VENTED Open BUTT END VENTED Open SHELL VENTED Open

WINDING RESISTANCE @ 23°C — OHMS	HI 1.50	MED/HI 2.40	LO 3.30	AUX. 36.00	Temp. °C 23	Enclosure All position Open Motor
----------------------------------	------------	----------------	------------	---------------	----------------	---

DESIGN NOTES: MOTOR SAME AS _____ or A DESIGN OF GE 3587

SPECIAL CONSIDERATIONS: ***Motor HP ratings are 1/2, 9.8A; 1/3, 8.0A; 1/4, 6.4A.** • Motor Design Capacitor is 7.5/370, for use of other capacitors see instructions shipped with motor. Motor is shipped with Emerson Instructions F10676, Rheem Instruction 92-26177-220-00. Motors are shipped with instructions, four (4) extra thru bolt nuts in a plastic bag. Print is prepared from Emerson's data.

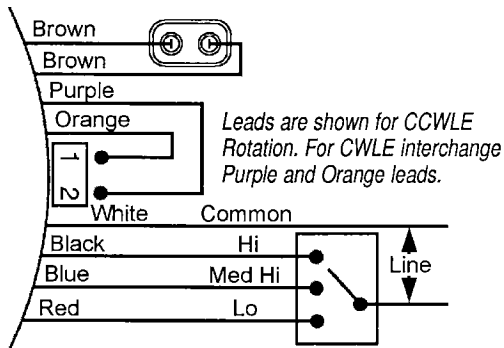

Wire Information: Lead Insulation Rating 105°C
Thickness 4/64" Type Material PVC

Leads	Color	Wire Ga.	Length	Termination
Common	White	18	36"	1/4 QC Flag
High	Black	18	36"	1/4 QC Flag
M/Hi	Blue	18	36"	1/4 QC Flag
Lo	Red	18	36"	1/4 QC Flag
Capacitor	Brown	18	36"	1/4 QC Flag
Capacitor	Brown	18	36"	1/4 QC Flag
Ground	Green	18	5"	1/4 Eyelet

Reversing Leads are (1) Orange and (1) Purple 4" Long

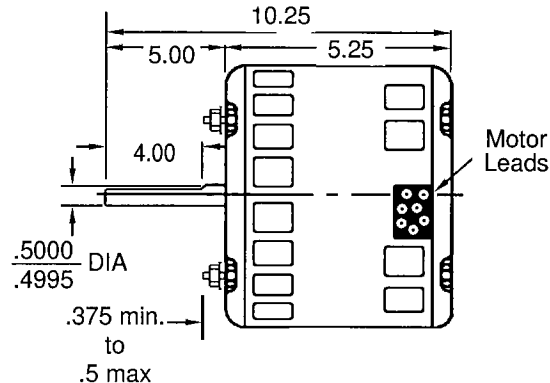
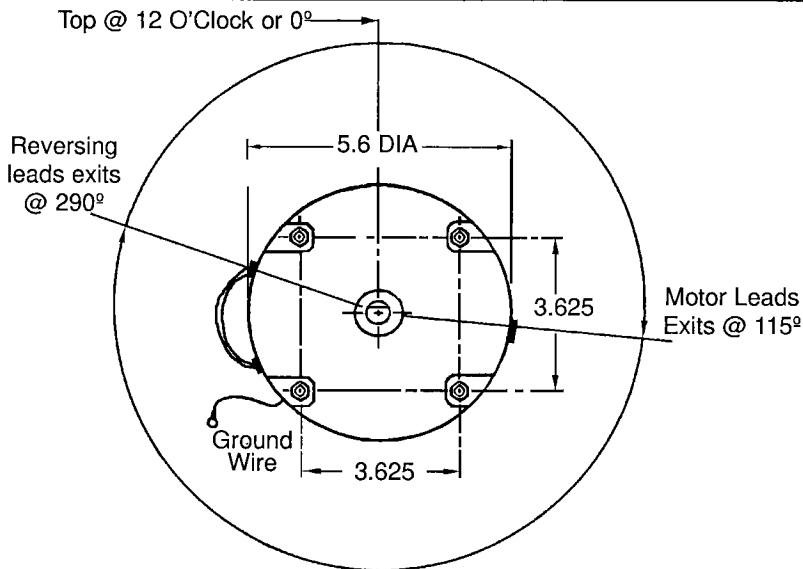

NOTE: Thru Bolts (8-32) are Reversible.
Four (4) extra nuts Shipped in bag W/Motor

PARTS DEPARTMENT

RHEEM MANUFACTURING CO.

Stuffer Number Changed from R920124FT220B to 92-26177-220-00 Y-0119S000 04/15/1999

00 REVISIONS

DR. BY: W. Charles | CHKD. BY: Robert Thomas | APPROVED BY: Baykal Altiner | DATE 05/03/1999 | ORIGINAL RELEASE Y-0119S000 | REV. -00

1/2 HP 3 Speed (115V) Direct Drive Furnace Blower Motor

PART NO. 51 - 23012 - 31