



The new degree of comfort.™

## Rheem Classic® Series Heat Pump

### RP15 Series

Efficiencies up to 15 SEER/12.5 EER  
Nominal Sizes 1½ to 5 Ton [5.28 to 17.6 kW]  
Cooling Capacities 17.3 to 60.5 kBTU  
[5.7 to 17.7 kW]



*“Proper sizing and installation of equipment is critical to achieve optimal performance. Split system air conditioners and heat pumps must be matched with appropriate coil components to meet Energy Star. Ask your Contractor for details or visit [www.energystar.gov](http://www.energystar.gov).”*

- New composite base pan – dampens sound, captures louver panels, eliminates corrosion and reduces number of fasteners needed
- Improved tubing design – reduces vibration and stress, making unit quieter and reducing opportunity for leaks
- Optimized defrost characteristics - decrease defrosting and provide better home comfort
- Powder coat paint system – for a long lasting professional finish
- Optimized reversing valve sizing – improves shifting performance for quieter unit operation and increased life of the system
- Enhanced mufflers – help to dissipate vibration energy for quieter unit operation
- Scroll compressor – a sound abating feature added to the compressor significantly reduces noise when system transitions in and out of defrost mode
- Modern cabinet aesthetics – increased curb appeal with visually appealing design
- Curved louver panels – provide ultimate coil protection, enhance cabinet strength, and increased cabinet rigidity
- Optimized fan orifice – optimizes airflow and reduces unit sound
- Rust resistant screws – confirmed through 1500-hour salt spray testing
- **PlusOne™ Expanded Valve Space** – 3"-4"-5" service valve space – provides a minimum working area of 27-square inches for easier access
- Integrated heat pump lift receptacle – allows standard CPVC stands to be inserted into the base
- **PlusOne™ Triple Service Access** – 15" wide, industry leading corner service access – makes repairs easier and faster. The two fastener removable corner allows optimal access to internal unit components. Individual louver panels come out once fastener is removed, for faster coil cleaning and easier cabinet reassembly
- Diagnostic service window with two-fastener opening – provides access to the TXV valves and the heat pump reversing valve before opening the unit.
- External gauge port access – allows easy connection of “low-loss” gauge ports
- Single-row condenser coil – makes unit lighter and allows thorough coil cleaning to maintain “out of the box” performance
- 35% fewer cabinet fasteners and fastener-free base – allow for faster access to internal components and hassle-free panel removal
- Service trays – hold fasteners or caps during service calls
- QR code – provides technical information on demand for faster service calls
- Fan motor harness with extra-long wires – allows unit top to be removed without disconnecting fan wire



## TABLE OF CONTENTS

Standard Feature Table .....	3
Available SKUs .....	3
Features & Benefits .....	4-5
Model Number Identification .....	6-7
Physical Data .....	8
Electrical Data .....	8
Accessories .....	9
Weighted Sound Power .....	9
Unit Dimensions.....	10
Clearances.....	11
Wiring Diagrams .....	12
Application Guidelines .....	12
Refrigerant Line Size Information .....	13-16
Performance Data .....	17
Guide Specifications .....	18
Limited Warranty .....	19



Air

## Standard Feature Table

Feature	18	24	30	36	42	48	60
R-410a Refrigerant	√	√	√	√	√	√	√
Maximum SEER	15.0	15.0	15.0	15.0	15.0	15.0	15.0
Maximum EER	12.5	12.5	12.5	12.5	12.5	12.5	12.5
Maximum HSPF	9	9	9	9	9	9	9
Scroll Compressor	√	√	√	√	√	√	√
Field Installed Filter Drier	√	√	√	√	√	√	√
Front Seating Service Valves	√	√	√	√	√	√	√
High Pressure Switch	√	√	√	√	√	√	√
Low Pressure Switch	√	√	√	√	√	√	√
Internal Pressure Relief Valve	√	√	√	√	√	√	√
Internal Thermal Overload	√	√	√	√	√	√	√
Long Line capability	√	√	√	√	√	√	√
Low Ambient capability with Kit	√	√	√	√	√	√	√
3-4-5 Service Valve Access	√	√	√	√	√	√	√
Composite Basepan	√	√	√	√	√	√	√
2 Screw Control Box Access	√	√	√	√	√	√	√
15" Access to Internal Components	√	√	√	√	√	√	√
Quick release louver panel design	√	√	√	√	√	√	√
No fasteners to remove along bottom	√	√	√	√	√	√	√
Optimized Venturi Airflow	√	√	√	√	√	√	√
Single row condenser coil	√	√	√	√	√	√	√
Powder coated paint	√	√	√	√	√	√	√
Rust resistant screws	√	√	√	√	√	√	√
QR code	√	√	√	√	√	√	√
External gauge ports	√	√	√	√	√	√	√
Service trays	√	√	√	√	√	√	√

√ = Standard

## Available SKUs

Available Models	Description
RP1518BJ1NA	Classic® 1 1/2 ton 15 SEER Single-Stage Heat Pump-208/230/1/60
RP1518CJ1NA	Classic® 1 1/2 ton 15 SEER Single-Stage Heat Pump-208/230/1/60
RP1524BJ1NA	Classic® 2 ton 15 SEER Single-Stage Heat Pump-208/230/1/60
RP1530BJ1NA	Classic® 2 1/2 ton 15 SEER Single-Stage Heat Pump-208/230/1/60
RP1536AC1NA	Classic® 3 ton 15 SEER Single-Stage Heat Pump-208/230/3/60
RP1536AJ1NA	Classic® 3 ton 15 SEER Single-Stage Heat Pump-208/230/1/60
RP1542BC1NA	Classic® 3 1/2 ton 15 SEER Single-Stage Heat Pump-208/230/3/60
RP1542BJ1NA	Classic® 3 1/2 ton 15 SEER Single-Stage Heat Pump-208/230/1/60
RP1548AC1NA	Classic® 4 ton 15 SEER Single-Stage Heat Pump-208/230/3/60
RP1548AJ1NA	Classic® 4 ton 15 SEER Single-Stage Heat Pump-208/230/1/60
RP1560AC1NA	Classic® 5 ton 15 SEER Single-Stage Heat Pump-208/230/3/60
RP1560AJ1NA	Classic® 5 ton 15 SEER Single-Stage Heat Pump-208/230/1/60



## Introduction to RP15 Heat Pump

The RP15 is our 15 SEER heat pump and is part of the Rheem heat pump product line that extends from 14 to 20 SEER. This highly featured and reliable heat pump is designed for years of reliable, efficient operation when matched with Rheem indoor aluminum evaporator coils and furnaces or air handler units with aluminum evaporators.

Our unique composite base (1) reduces sound emission, eliminates rattles, significantly reduces fasteners, eliminates corrosion and has integrated brass compressor attachment inserts (2). Furthermore it has incorporated into the design, water management features, means for hand placement (3) for unit maneuvering, screw trays (4) and inserts for lifting unit off pad. (5)

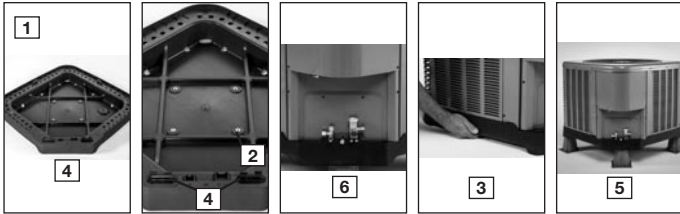

Service valves (6) are rigidly mounted in the composite base with 3" between suction and discharge valves, 4" clearance below service valves and a minimum of 5" above the service valves, creating industry leading installation ease. The minimum 27-square inches around the service valves allows ample room to remove service valve schrader prior to brazing, plenty of clearance for easy brazing of the suction and discharge lines to service valve outlets, easy access and hookup of low loss refrigerant gauges (7), and access to the service valve caps for opening. For applications with long-line lengths up to 250 feet total equivalent length, up to 200 feet heat pump above evaporator, or up to 80 feet evaporator above heat pump, the long-line instructions in the installation manual should be followed.

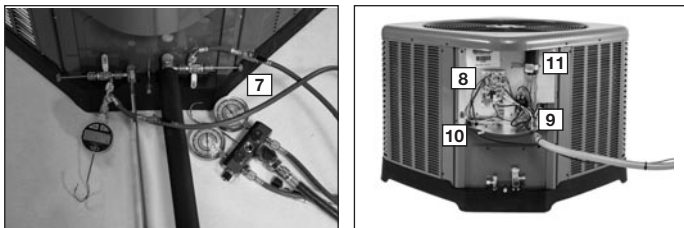

Controls are accessed from the corner of the unit by removing only two fasteners from the control access cover, revealing the industry's largest 15" wide and 14" tall control area (8). With all this room in the control area the high voltage electrical whip (9) can easily be inserted through the right size opening in the bottom of the control area. Routing it leads directly to contractor lugs for connection. The low voltage control wires (10) are easily connected to units low voltage wiring. If contactor, defrost control or capacitor (11) needs to be replaced there is more than adequate space to make the repair. Furthermore, the service window (12) can be removed to access the TXV and reversing valve by removing two screws or the entire corner can be removed providing ultimate access to the TXV or reversing valve. (13)

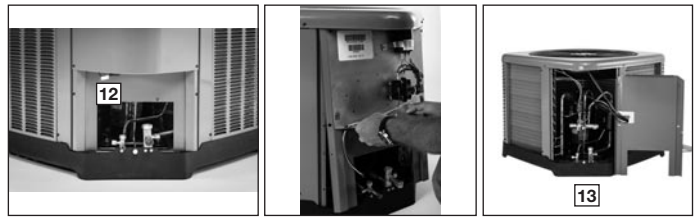

If in the rare event, greater access is needed to internal components, such as the compressor, the entire corner of the unit can be removed along with the top cover assembly to have unprecedented access to interior of the unit (14). Extra wire length is incorporated into each outdoor fan and compressor so top cover and control panel can be positioned next to unit. With minimal effort the plug panel can be removed from the compressor and the outdoor fan wires can be removed from the capacitor to allow even more uncluttered access to the interior of the unit (15). Outdoor coils heights range from as short as 25" to 45", aiding access to the compressor. Disassembly to this degree and complete reassembly only takes a first time service technician less than 10 minutes. (18)

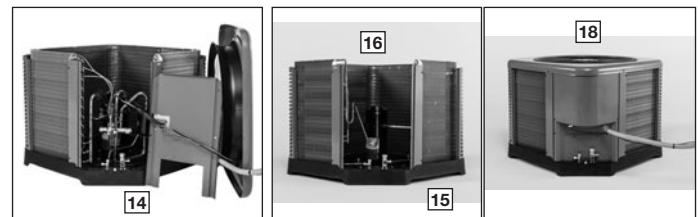

All units utilize strong formed louver panels which provide industry leading coil protection. Louver removal for coil cleaning is accomplished by removing one screw and lifting the panel out of the composite base pan (17). All RP15 units utilize single row coils (16) making cleaning easy and complete, restoring the performance of the heat pump back to out of the box performance levels year after year.



The outdoor fan motor has sleeve bearings and is inherently protected. The motor is totally enclosed for maximum protection from weather, dust and corrosion. Access to the outdoor fan is made by removing four fasteners from the fan grille. The outdoor fan can be removed from the fan grille by removing 4 fasteners in the rare case outdoor fan motor fails.

Each cabinet has optimized composite (19) fan orifice assuring efficient and quiet airflow.



The entire cabinet has powder post paint (20) achieving 1000 hour salt spray rating, allowing the cabinet to retain its aesthetics throughout its life.

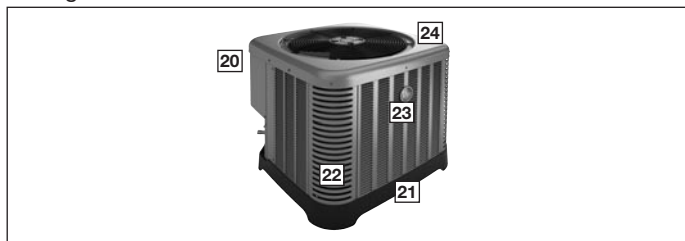

Scroll compressors with standard internal pressure relief and internal thermal overload are used on all capacities assuring longevity of high efficient and quiet operation for the life of the product. All RP15 Heat Pumps come standard with high and low pressure switches.

Each unit is shipped with filter drier for field installation and will trap any moisture or dirt that could contaminate the refrigerant system.



All cabinets have industry leading structural strength due to the composite base pan (21), interlocking corner post (22), formed curved louver panels (23) and drawn top cover (24) making it the most durable cabinet on the market today.

Each RP15 capacity has undergone rigorous psychrometric testing to assure performance ratings of capacity, SEER, EER and HSPF per AHRI Standard 210/240 rating conditions. Also each unit bears the UL mark and each unit is certified to UL 1995 safety standards.



Each unit has undergone specific strain and modal testing to assure tubing (25) is outside the units natural frequency and that the suction and discharge lines connected to the compressor withstand any starting, steady state operation or shut down forces imposed by the compressor.

All units have been sound tested in sound chamber to AHRI 270 rating conditions, and A-weighted Sound Power Level tables produced, assuring units have acceptable noise qualities (see page 9). Each unit has been ran in cooling operation at 95°F and 47°F and sound ratings for the RP15 range from as low as 73 dBA to 79 dBA.

All units have been ship tested to assure units meet stringent “over the road” shipping conditions.

As manufactured all units in the RP15 family have cooling capability to 55 °F. Addition of low ambient control will allow the unit to operate down to 0°F.

Factory testing is performed on each unit. All component parts meet well defined specification and continually go through receiving inspections. Each component installed on a unit is scanned, assuring correct component utilization for a given unit capacity and voltage. All condenser coils are leak tested with pressurization test to 550#’s and once installed and assembled, each units’ complete refrigerant system is helium leak tested. All units are fully charged from the factory for up to 15 feet of piping. All units are factory run tested. The RP15 has a 10-year conditional compressor and parts warranty (registration required).

**Optional Accessories (Refer to accessory chart for model #)**

**Compressor Crankcase Heater**

- Protects against refrigerant migration that can occur during low ambient operation

**Compressor Sound Cover**

- Reinforced vinyl compressor cover containing a 1½ inch thick batt of fiberglass insulation
- Open edges are sealed with a one-inch wide hook and loop fastening tape

**Compressor Hard Start Kit**

- Single-phase units are equipped with a PSC compressor motor. This type of motor normally does not need a potential relay and start capacitor
- In conditions such as low voltage, this kit may be required to increase the compressor starting torque

**Low Ambient Kit**

- Heat Pump operate satisfactorily in the cooling mode down to 55°F outdoor air temperature without any additional controls
- Kit can be added in the field enabling unit to operate properly down to 0° in the cooling mode
- Crankcase heater and freezestat should be installed on compressors equipped with a low ambient kit

**3"/6"/12"**

- Gray high density polyethylene feet are available to raise unit off of mounting surface away from moisture



# Heat Pumps

<u>R</u>	<u>P</u>	<u>15</u>	<u>24</u>	<u>A</u>	<u>J</u>	<u>1</u>	<u>N</u>	<u>A</u>	<u>*</u>
Brand	Product Category	SEER	Capacity BTU/HR	Major Series*	Voltage	Type	Controls	Minor Series**	Option Code
Rheem	P - Heat Pump	15 - 15 SEER	18 - 18,000 [5.28 kW] 24 - 24,000 [7.03 kW] 30 - 30,000 [8.79 kW] 36 - 36,000 [10.55 kW] 42 - 42,000 [12.31 kW] 48 - 48,000 [14.07 kW] 60 - 60,000 [17.58 kW]	A - 1st Design B - 2nd Design C - 3rd Design	J - 1ph, 208-230/60 C - 3ph, 208-230/60	1 - Single-stage	C - Communicating	A - 1st Design B - 2nd Design	N/A

# Air Conditioners (For Reference)

<u>R</u>	<u>A</u>	<u>14</u>	<u>24</u>	<u>A</u>	<u>J</u>	<u>1</u>	<u>N</u>	<u>A</u>	<u>*</u>
Brand	Product Category	SEER	Capacity BTU/HR [kW]	Major Series*	Voltage	Type	Controls	Minor Series**	Option Code
Rheem	A - Air Conditioners	13 - 13 SEER 14 - 14 SEER 16 - 16 SEER 17 - 17 SEER 20 - 20 SEER	18 - 18,000 [5.28 kW] 24 - 24,000 [7.03 kW] 30 - 30,000 [8.79 kW] 36 - 36,000 [10.55 kW] 42 - 42,000 [12.31 kW] 48 - 48,000 [14.07 kW] 60 - 60,000 [17.58 kW]	A - 1st Design B - 2nd Design	J - 1ph, 208-230/60 C - 3ph, 208-230/60 D - 3ph, 460/60	1 - Single-stage 2 - Two-stage V - Inverter	C - Communicating N - Non-communicating	A - 1st Design B - 2nd Design	N/A

# Furnace Coils (For Reference)

<u>R</u>	<u>C</u>	<u>F</u>	<u>24</u>	<u>17</u>	<u>S</u>	<u>I</u>	<u>A</u>	<u>M</u>	<u>C</u>	<u>A</u>	<u>*</u>
Brand	Product Category	Type	Capacity BTU/HR	Width	Efficiency	Metering Device	Major Series*	Orientation	Casing	Minor Series**	Option Code
Rheem	C - Evap Coil F - Furn Coil H - Air-Handler Coil	F - Furn Coil H - Air-Handler Coil	24 - 24,000 [7.03 kW] 36 - 36,000 [10.55 kW] 48 - 48,000 [14.07 kW] 60 - 60,000 [17.58 kW]	14 - 14" 17 - 17.5" 21 - 21" 24 - 24.5"	S - Standard Eff. M - Mid Eff. H - High Eff.	T-TXV E-EEV P-Piston	A - 1st Design	M - Multi-poise	C - Cased U - Uncased	A - 1st Design B - 2nd Design	N/A

[ ] Designates Metric Conversions



## 90%+ AFUE Gas Furnaces (For Reference)

<u>R</u>	<u>96</u>	<u>V</u>	<u>A</u>	<u>70</u>	<u>2</u>	<u>3</u>	<u>17</u>	<u>M</u>	<u>S</u>	<u>A</u>
Brand	Series	Motor	Major Rev	Input BTU/HR [kW]	Stages	Air Flow	Cabinet Width	Configuration	NOx	Minor Rev
Rheem	92 - 92 AFUE	V - Variable speed	A - 1st Design	040 - 42,000 [12.31 kW]	1 - Single-stage	3 - up to 3 ton	14 - 14"	M - Multi-poise	X - Low NOx	A - 1st Design
	95 - 95 AFUE	T - Constant Torque (X-13)	B - 2nd Design	060 - 56,000 [16.41 kW]	2 - Two-stage	5 - 3 1/2 up to 5 ton	17 - 17.5"	U - Upflow	S - Standard	B - 2nd Design
	96 - 96 AFUE			070 - 70,000 [20.51 kW]	M - Modulating		21 - 21"	K - Downflow		
	97 - 97 AFUE			085 - 84,000 [24.62 kW]			24 - 24.5"			
	98 - 98 AFUE			100 - 98,000 [28.72 kW]						
				115 - 112,000 [32.82 kW]						

## 80% AFUE Gas Furnaces (For Reference)

<u>R</u>	<u>80</u>	<u>2</u>	<u>V</u>	<u>A</u>	<u>075</u>	<u>3</u>	<u>17</u>	<u>M</u>	<u>S</u>	<u>A</u>
Brand	Series	Stages	Motor	Major Rev	Input BTU/HR [kW]	Air Flow	Cabinet Width	Configuration	NOx	Minor Rev
Rheem	80 - 80+ AFUE	1 - Single-stage	V - Variable speed	A - 1st Design	050 - 50,000 [15 kW]	3 - up to 3 ton	14 - 14"	M - Multi	X - Low NOx	A - 1st Design
		2 - Two-stage	T - Constant Torque (X-13)	B - 2nd Design	075 - 75,000 [22 kW]	4 - 2 1/2 to 4 ton	17 - 17.5"	D - Down	S - Standard	B - 2nd Design
					100 - 100,000 [29 kW]	5 - 3 1/2 up to 5 ton	21 - 21"	Z - Down & zero clearance		
					125 - 125,000 [37 kW]		24 - 24.5"	down flow		
					150 - 150,000 [44 kW]					

## Air Handlers (For Reference)

<u>R</u>	<u>H</u>	<u>1</u>	<u>I</u>	<u>36</u>	<u>17</u>	<u>S</u>	<u>I</u>	<u>A</u>	<u>N</u>	<u>A</u>	<u>*</u>	
Brand	Product Category	Stages of Airflow	Motor Type	Capacity BTU/HR	Width	Coil Size	Metering Device	Major Series*	Controls	Voltage	Minor Series**	Factory Heat Cap Code
Rheem	H - Air Handler	1 - Single-stage	V - Variable Speed	24 - 24,000 [7.03 kW]	14 - 14"	S - Standard Efficiency	T - TEV	A - 1st Design	C - Communicating	A - 1ph, 115/60	A - 1st Design	00 - no
		2 - Two-stage	T - Constant Torque	36 - 36,000 [10.55 kW]	17 - 17.5"	M - Mid Efficiency	E - EEV	B - 2nd Design	N - Non-communicating	J - 1ph, 208-240/60	Design factory	N/A
		M - Modulating	P - PSC	48 - 48,000 [14.07 kW]	21 - 21"	H - High Efficiency	P - Piston			D - 3ph, 480/60	B - 2nd Design	heat with option code
				60 - 60,000 [17.58 kW]	24 - 24.5"						Design option code	

[ ] Designates Metric Conversions



Air



Air

Physical Data/Electrical Data  
RP15 Series

<b>Physical Data</b>							
Model No. #	RP1518	RP1524	RP1530	RP1536	RP1542	RP1548	RP1560
<b>Nominal Tonnage</b>	1.5	2.0	2.5	3.0	3.5	4.0	5.0
<b>Valve Connections</b>							
Liquid Line O.D. – in.	3/8	3/8	3/8	3/8	3/8	3/8	3/8
Suction Line O.D. – in.	3/4	3/4	3/4	3/4	7/8	7/8	7/8
<b>Refrigerant (R410A) furnished oz.<sup>1</sup></b>	123	105	116	118	192	188	217
<b>Compressor Type</b>	Scroll						
<b>Outdoor Coil</b>							
Net face area – Outer Coil ft <sup>2</sup>	11.1	11.1	17.3	19.8	24.2	24.2	28.3
Net face area – Inner Coil	—	—	—	—	—	—	—
Tube diameter – in.	3/8	3/8	3/8	3/8	3/8	3/8	3/8
Number of rows	1	1	1	1	1	1	1
Fins per inch	20	20	20	20	20	20	20
<b>Outdoor Fan</b>							
Diameter – in.	20	20	24	24	24	26	26
Number of blades	2	3	3	3	3	3	3
Motor hp	1/8	1/8	1/5	1/3	1/5	1/3	1/5
CFM	2478	2478	3850	3121	4900	4380	3655
RPM	1077	1075	825	910	825	870	850
watts	151	138	197	134	201	266	274
<b>Shipping weight – lbs.</b>	159	159	198	206	264	264	285
<b>Operating weight – lbs.</b>	152	152	191	199	257	257	278

<b>Electrical Data</b>							
Line Voltage Data (Volts-Phase-Hz)	208/230-1-60	208/230-1-60	208/230-1-60	208/230-1-60	208/230-1-60	208/230-1-60	208/230-1-60
<b>Maximum overcurrent protection (amps)<sup>2</sup></b>	20/20	25	25	35	45	40	50
<b>Minimum circuit ampacity<sup>3</sup></b>	12/12	15	18	23	27	26	31
<b>Compressor</b>							
Rated load amps	9/9	10.9	12.8	15.4	18.6	18.5	23.7
Locked rotor amps	48.0	62.9	67.8	83.9	109	124	152.5
<b>Condenser Fan Motor</b>							
Full load amps	0.75	0.7	1	2.8	1	2.8	1
Locked rotor amps	1.3	1.3	1.2	—	1.2	—	2.3
<b>Line Voltage Data (Volts-Phase-Hz)</b>	—	—	—	208/230-3-60	208/230-3-60	208/230-3-60	208/230-3-60
Maximum overcurrent protection (amps) <sup>2</sup>	—	—	—	25	31	30	35
Minimum circuit ampacity <sup>3</sup>	—	—	—	16	19	21	21
<b>Compressor</b>							
Rated load amps	—	—	—	10.4	12.5	13.8	15.9
Locked rotor amps	—	—	—	73	84	83.1	110
<b>Condenser Fan Motor</b>							
Full load amps	—	—	—	2.8	1	2.8	1
Locked rotor amps	—	—	—	—	1.2	—	2.3

<sup>1</sup>Refrigerant charge sufficient for 15 ft. length of refrigerant lines. For longer line set requirements see the installation instructions for information about set length and additional refrigerant charge required.

<sup>2</sup>HACR type circuit breaker or fuse.

<sup>3</sup>Refer to National Electrical Code manual to determine wire, fuse and disconnect size requirements.





## Accessories

Model No.	RP1518	RP1524	RP1530	RP1536	RP1542	RP1548	RP1560
Compressor crankcase heater	44-17402-44	44-17402-44	44-17402-44	44-17402-44	44-17402-45	Factory Standard	Factory Standard
Low ambient control	RXAD-A08	RXAD-A08	RXAD-A08	RXAD-A08	RXAD-A08	RXAD-A08	RXAD-A08
Compressor sound cover	68-23427-26	68-23427-26	68-23427-26	68-23427-26	68-23427-25	68-23427-25	68-23427-25
Compressor hard start kit	SK-A1	SK-A1	SK-A1	SK-A1	SK-A1	SK-A1	SK-A1
Low pressure control*	Factory Standard	Factory Standard	Factory Standard	Factory Standard	Factory Standard	Factory Standard	Factory Standard
High pressure control*	Factory Standard	Factory Standard	Factory Standard	Factory Standard	Factory Standard	Factory Standard	Factory Standard
Liquid Line Solenoid (24 VAC, 50/60 Hz)	Solenoid Valve	200RD2T3TVLC	200RD2T3TVLC	200RD2T3TVLC	200RD2T3TVLC	200RD2T3TVLC	200RD3T3TVLC
	Solenoid Coil	61-AMG24V	61-AMG24V	61-AMG24V	61-AMG24V	61-AMG24V	61-AMG24V
	Bi-flow kit*	KS30387	KS30387	KS30387	KS30387	KS30387	KS30387
Liquid Line Solenoid (120/240 VAC, 50/60 Hz)	Solenoid Valve	200RD2T3TVLC	200RD2T3TVLC	200RD2T3TVLC	200RD2T3TVLC	200RD2T3TVLC	200RD3T3TVLC
	Solenoid Coil	61-AMG120/240V	61-AMG120/240V	61-AMG120/240V	61-AMG120/240V	61-AMG120/240V	61-AMG120/240V
	Bi-flow kit*	KS30387	KS30387	KS30387	KS30387	KS30387	KS30387
Classic Top Cap w/Label	91-101123-21	91-101123-21	91-101123-21	91-101123-21	91-101123-21	91-101123-21	91-101123-21
Heat Pump Riser – 6 inch	686020	686020	686020	686020	686020	686020	686020

\*Bi-flow kits are required when installing a liquid line solenoid on a heat pump.

## Weighted Sound Power Level (dBA)

Unit Size – Voltage, Series	Standard Rating (dBA)	TYPICAL OCTAVE BAND SPECTRUM (dBA without tone adjustment)						
		125	250	500	1000	2000	4000	8000
RP1518	76.4	53.7	61.8	66.2	66.8	62.9	58	52
RP1524	76.4	53.7	61.3	66.2	66.8	62.9	58	52
RP1530	75.3	53.2	55.4	64.3	65.6	63.1	59.2	57
RP1536	74.7	48.9	54.3	63.1	66.4	62.2	55.2	53.2
RP1542	73.0	49.3	55.3	65.1	60.6	57.9	55.2	48.3
RP1548	76.5	55.8	59	68.2	66.3	64.3	60.5	55.4
RP1560	73.9	58.9	55.7	63.4	63.3	61.5	58.6	56.4

NOTE: Tested in accordance with AHRI Standard 270-08 (not listed in AHRI)

## Unit Dimensions

MODEL NUMBER	OPERATING						SHIPPING					
	H (Height)		L (Length)		W (Width)		H (Height)		L (Length)		W (Width)	
	INCHES	mm	INCHES	mm	INCHES	mm	INCHES	mm	INCHES	mm	INCHES	mm
RP1518	25	635	29.75	755	29.75	755	26.50	673	32.38	822	32.38	822
RP1524	25	635	29.75	755	29.75	755	26.75	679	32.38	822	32.38	822
RP1530	31	787	33.75	857	33.75	857	32.75	831	32.38	822	32.38	822
RP1536	35	889	33.75	857	33.75	857	36.75	933	36.38	924	36.38	924
RP1542	39	991	35.75	908	35.75	908	40.50	1029	38.38	975	38.38	975
RP1548	39	991	35.75	908	35.75	908	40.75	1035	38.38	975	38.38	975
RP1560	45	1143	35.75	908	35.75	908	46.75	1187	38.38	975	38.38	975

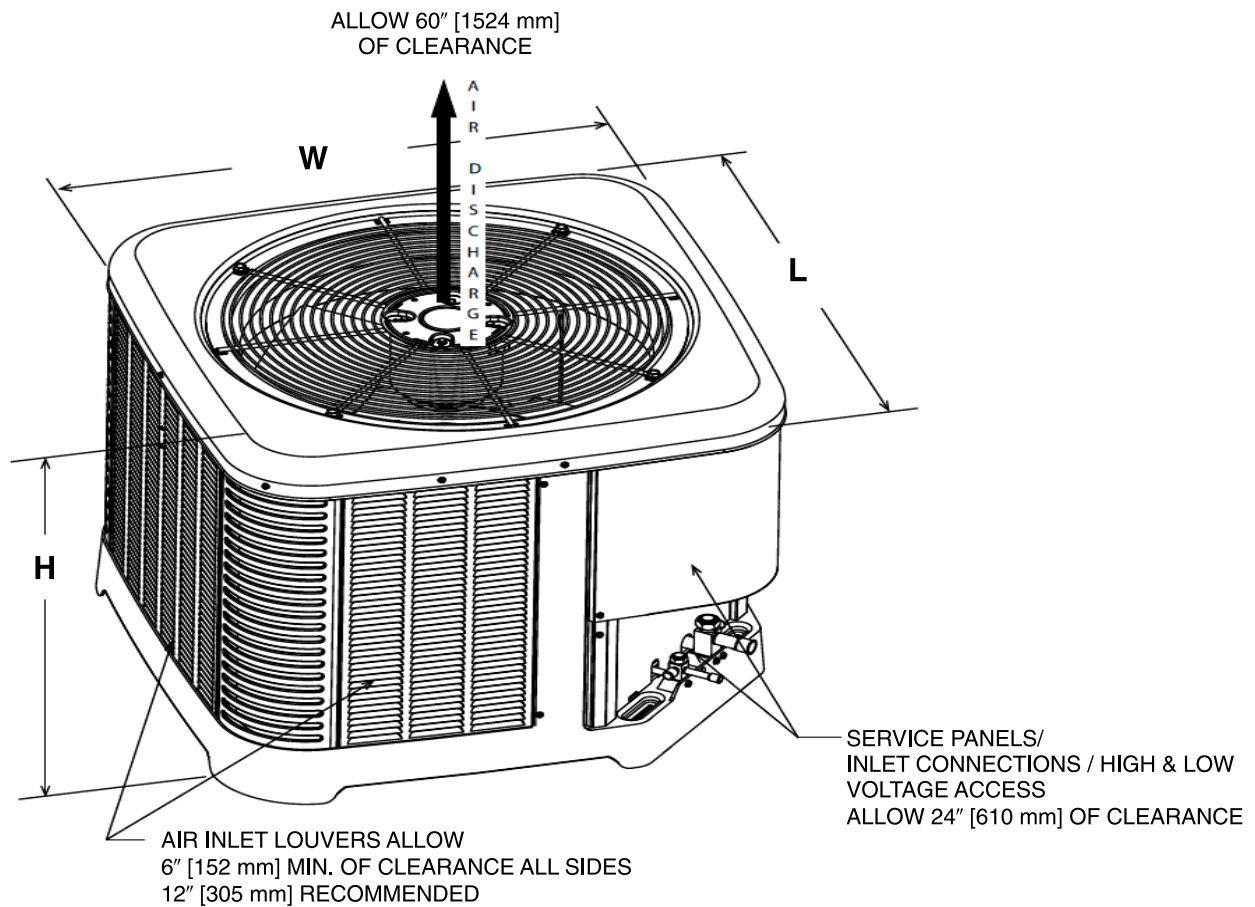

[ ] Designates Metric Conversions

ST-A1226-02-00



## Control Wiring

**FIGURE 4**  
**CONTROL WIRING FOR AIR HANDLER**

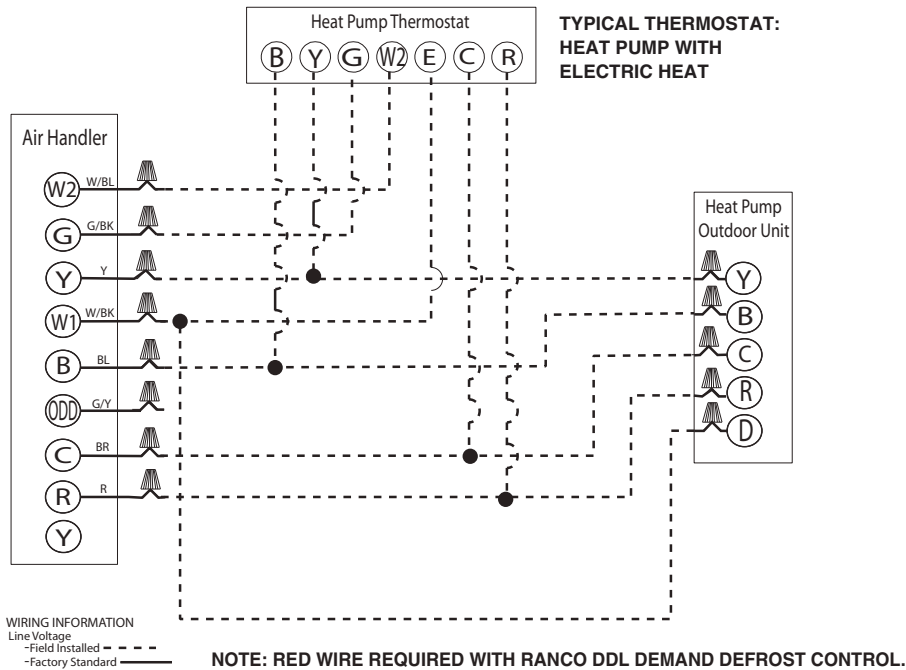

**NOTES:**

1. Jumper "E" to "W2" to transfer control of supplemental heat to 1st stage when the emergency heat switch is on.
2. This wire turns on heat for defrost, omit for most economical operation.
3. Wire with colored tracing stripe.

## Application Guidelines

1. Intended for outdoor installation with free air inlet and outlet. Outdoor fan external static pressure available is less than 0.01-in. wc.
2. Minimum outdoor operation air temperature for cooling mode without low-ambient operation accessory is 55°F (12.8°C).
3. Maximum outdoor operating air temperature is 125°F (51.7°C).
4. For reliable operation, unit should be level in all horizontal planes.
5. Use only copper wire for electric connections at unit. Aluminum and clad aluminum are not acceptable for the type of connector provided.
6. Do not apply capillary tube indoor coils to these units.
7. Factory – supplied filter drier must be installed.

**Table 2A: Refrigerant Line Sizing Chart (English Units)**

15 SEER Single-Stage Heat Pumps															
Unit Size	Allowable Liquid Line Size	Allowable Vapor Line Size	(-)P15	Outdoor Unit ABOVE or BELOW Indoor Unit Equivalent Length (Feet)											
				< 25	26-50	51-75	76-100	101-125	126-150	151-175	176-200	201-225	226-250		
				Maximum Vertical Separation / Capacity Multiplier											
1.5 Ton* SEE NOTE 3	1/4"	5/8"	98	25/1.00	50/0.99	62/0.98	43/0.98	24/0.97	5/0.97	N/R	N/R	N/R	N/R	N/R	N/R
	5/16"	5/8"	78	25/1.00	50/0.99	75/0.98	98/0.98	93/0.97	88/0.97	83/0.96	78/0.96	73/0.95	68/0.94		
	3/8"	5/8"	57	25/1.00	50/0.99	75/0.98	100/0.98	100/0.97	100/0.97	100/0.96	100/0.96	100/0.95	100/0.94		
	1/4"	3/4**	98	25/1.00	50/1.00	62/0.99	43/0.99	24/0.99	5/0.99	N/R	N/R	N/R	N/R		
	5/16"	3/4**	78	25/1.00	50/1.00	75/0.99	98/0.99	93/0.99	88/0.99	83/0.99	78/0.98	73/0.98	68/0.98		
	3/8"	3/4**	57	25/1.00	50/1.00	75/1.00	100/0.99	100/0.99	100/0.99	100/0.99	100/0.98	100/0.98	100/0.98		
		1/4"	5/8"	N/A	25/0.99	50/0.98	21/0.97	N/R	N/R	N/R	N/R	N/R	N/R	N/R	
2 Ton	5/16"	5/8"	123	25/0.99	50/0.98	75/0.97	87/0.96	77/0.95	69/0.94	61/0.93	53/0.92	45/0.91	37/0.90		
	3/8"	5/8"	82	25/0.99	50/0.98	75/0.97	100/0.96	100/0.95	100/0.94	98/0.93	95/0.92	93/0.91	90/0.90		
	1/4"	3/4"	N/A	25/1.00	50/1.00	21/0.99	N/R	N/R	N/R	N/R	N/R	N/R	N/R		
	5/16"	3/4"	123	25/1.00	50/1.00	75/0.99	87/0.99	77/0.98	69/0.98	61/0.98	53/0.97	45/0.97	37/0.96		
	3/8"	3/4"	82	25/1.00	50/1.00	75/0.99	100/0.99	100/0.98	100/0.98	98/0.98	95/0.97	93/0.97	90/0.96		
		5/16"	5/8"	103	25/0.99	50/0.98	75/0.96	70/0.94	59/0.93	48/0.91	36/0.90	N/R	N/R	N/R	
		3/8"	5/8"	68	25/0.99	50/0.98	75/0.96	100/0.94	98/0.93	94/0.91	90/0.90	N/R	N/R	N/R	
2.5 Ton	5/16"	3/4"	103	25/1.00	50/0.99	75/0.99	70/0.98	59/0.98	48/0.97	36/0.96	25/0.96	13/0.95	N/R		
	3/8"	3/4"	68	25/1.00	50/0.99	75/0.99	100/0.98	98/0.98	94/0.97	90/0.96	86/0.96	82/0.95	78/0.95		
		5/16"	5/8"	98	25/0.99	50/0.97	66/0.94	49/0.92	32/0.90	N/R	N/R	N/R	N/R		
		3/8"	5/8"	65	25/0.99	50/0.97	75/0.94	95/0.92	89/0.90	N/R	N/R	N/R	N/R		
		5/16"	3/4"	98	25/1.00	50/0.99	66/0.98	49/0.98	32/0.97	15/0.96	N/R	N/R	N/R		
		3/8"	3/4"	65	25/1.00	50/0.99	75/0.98	95/0.98	89/0.97	84/0.96	78/0.95	72/0.94	67/0.93	61/0.93	
		1/2"	3/4"	33	25/1.00	50/0.99	75/0.98	100/0.98	100/0.97	100/0.96	100/0.95	100/0.94	100/0.93	100/0.93	
3 Ton	5/16"	7/8"	98	25/1.00	50/1.00	66/1.00	49/0.99	32/0.99	15/0.99	N/R	N/R	N/R	N/R		
	3/8"	7/8"	65	25/1.00	50/1.00	75/1.00	95/0.99	89/0.99	84/0.99	78/0.98	72/0.98	67/0.98	61/0.97		
	1/2"	7/8"	33	25/1.00	50/1.00	75/1.00	100/0.99	100/0.99	100/0.99	100/0.98	100/0.98	100/0.98	100/0.97		
		3/8"	3/4"	93	25/0.99	50/0.98	75/0.97	88/0.96	80/0.95	72/0.94	65/0.92	57/0.91	49/0.90	N/R	
		1/2"	3/4"	47	25/0.99	50/0.98	75/0.97	100/0.96	100/0.95	100/0.94	100/0.92	100/0.91	100/0.90	N/R	
		3/8"	7/8"	93	25/1.00	50/1.00	75/0.99	88/0.99	80/0.99	72/0.98	65/0.97	57/0.97	49/0.96	42/0.96	
		1/2"	7/8"	47	25/1.00	50/1.00	75/0.99	100/0.99	100/0.99	100/0.98	100/0.97	100/0.97	100/0.96	100/0.96	

**Notes:**  
 1) Do not exceed 200 ft linear line length.  
 2) Do not exceed 100 ft vertical separation between indoor and outdoor units.  
 3) \*3/4" vapor line should only be used for 1.5 ton systems if outdoor unit is below or at same level as indoor unit to assure proper oil return.  
 4) Always use the smallest liquid line allowable to minimize refrigerant charge.  
 5) Applications shaded in light gray indicate capacity multipliers between 0.90 and 0.96 which are not recommended, but are allowed.  
 6) Applications shaded in dark gray are not recommended due to excessive liquid or suction line pressure drop.



Air

Table 2A: Refrigerant Line Sizing Chart (English Units) (con't.)

15 SEER Single-Stage Heat Pumps													
Unit Size	Allowable Liquid Line Size	Allowable Vapor Line Size	(-)P15	Outdoor Unit ABOVE or BELOW Indoor Unit Equivalent Length (Feet)									
				< 25	26-50	51-75	76-100	101-125	126-150	151-175	176-200	201-225	226-250
				Maximum Vertical Separation / Capacity Multiplier									
1.5 Ton* SEE NOTE 3	1/4"	5/8"	98	25 / 1.00	50 / 0.99	62 / 0.98	43 / 0.98	24 / 0.97	5 / 0.97	N/R	N/R	N/R	N/R
	5/16"	5/8"	78	25 / 1.00	50 / 0.99	75 / 0.98	98 / 0.98	93 / 0.97	88 / 0.97	83 / 0.96	78 / 0.96	73 / 0.95	68 / 0.94
	3/8"	5/8"	57	25 / 1.00	50 / 0.99	75 / 0.98	100 / 0.98	100 / 0.97	100 / 0.97	100 / 0.96	100 / 0.96	100 / 0.95	100 / 0.94
	1/4"	3/4**	98	25 / 1.00	50 / 1.00	62 / 0.99	43 / 0.99	24 / 0.99	5 / 0.99	N/R	N/R	N/R	N/R
	5/16"	3/4**	78	25 / 1.00	50 / 1.00	75 / 0.99	98 / 0.99	93 / 0.99	88 / 0.99	83 / 0.99	78 / 0.98	73 / 0.98	68 / 0.98
	3/8"	3/4**	57	25 / 1.00	50 / 1.00	75 / 1.00	100 / 0.99	100 / 0.99	100 / 0.99	100 / 0.99	100 / 0.99	100 / 0.98	100 / 0.98
2 Ton	1/4"	5/8"	N/A	25 / 0.99	50 / 0.98	21 / 0.97	N/R	N/R	N/R	N/R	N/R	N/R	N/R
	5/16"	5/8"	123	25 / 0.99	50 / 0.98	75 / 0.97	87 / 0.96	77 / 0.95	69 / 0.94	61 / 0.93	53 / 0.92	45 / 0.91	37 / 0.90
	3/8"	5/8"	82	25 / 0.99	50 / 0.98	75 / 0.97	100 / 0.96	100 / 0.95	100 / 0.94	98 / 0.93	95 / 0.92	93 / 0.91	90 / 0.90
	1/4"	3/4"	N/A	25 / 1.00	50 / 1.00	21 / 0.99	N/R	N/R	N/R	N/R	N/R	N/R	N/R
	5/16"	3/4"	123	25 / 1.00	50 / 1.00	75 / 0.99	87 / 0.99	77 / 0.98	69 / 0.98	61 / 0.98	53 / 0.97	45 / 0.97	37 / 0.96
	3/8"	3/4"	82	25 / 1.00	50 / 1.00	75 / 0.99	100 / 0.99	100 / 0.99	100 / 0.98	98 / 0.98	95 / 0.97	93 / 0.97	90 / 0.96

## Notes:

- 1) Do not exceed 200 ft vapor line length.
- 2) Do not exceed 100 ft vertical separation between indoor and outdoor units.
- 3) \* 3/4" vapor line should only be used for 1.5 ton systems if outdoor unit is below or at same level as indoor unit to assure proper oil return.
- 4) Always use the smallest liquid line allowable to minimize refrigerant charge.
- 5) Applications shaded in light gray indicate capacity multipliers between 0.90 and 0.96 which are not recommended, but are allowed.
- 6) Applications shaded in dark gray are not recommended due to excessive liquid or suction line pressure drop.

**Table 2B: Refrigerant Line Sizing Chart (Metric Units)**

15 SEER Single-Stage Heat Pumps													
Unit Size	Allowable Liquid Line Size mm [in.]	Allowable Vapor Line Size mm [in.]	(-)P15	Outdoor Unit ABOVE or BELOW Indoor Unit Equivalent Length (Meters)									
				< 8	8-15	16-23	24-30	31-38	39-46	47-53	54-61	62-69	70-76
				Maximum Vertical Separation / Capacity Multiplier									
5.3 kW [1.5 Ton] *SEE NOTE 3	6.35 [1/4]	15.88 [5/8]	30	8 / 1.00	15 / 0.99	19 / 0.98	13 / 0.98	7 / 0.97	2 / 0.97	N/R	N/R	N/R	N/R
	7.94 [5/16]	15.88 [5/8]	24	8 / 1.00	15 / 0.99	23 / 0.98	30 / 0.98	28 / 0.97	27 / 0.97	25 / 0.96	24 / 0.96	22 / 0.95	21 / 0.94
	9.53 [3/8]	15.88 [5/8]	17	8 / 1.00	15 / 0.99	23 / 0.98	30 / 0.98	30 / 0.97	30 / 0.97	30 / 0.97	30 / 0.96	30 / 0.95	30 / 0.94
	6.35 [1/4]	19.05 [3/4]*	30	8 / 1.00	15 / 1.00	19 / 0.99	13 / 0.99	7 / 0.99	2 / 0.99	N/R	N/R	N/R	N/R
	7.94 [5/16]	19.05 [3/4]*	24	8 / 1.00	15 / 1.00	23 / 0.99	30 / 0.99	28 / 0.99	27 / 0.99	25 / 0.99	24 / 0.98	22 / 0.98	21 / 0.98
	9.53 [3/8]	19.05 [3/4]*	17	8 / 1.00	15 / 1.00	23 / 0.99	30 / 0.99	30 / 0.99	30 / 0.99	30 / 0.99	30 / 0.98	30 / 0.98	30 / 0.98
7.0 kW [2 Ton]	6.35 [1/4]	15.88 [5/8]	N/A	8 / 0.99	15 / 0.98	6 / 0.97	N/R	N/R	N/R	N/R	N/R	N/R	N/R
	7.94 [5/16]	15.88 [5/8]	37	8 / 0.99	15 / 0.98	23 / 0.97	27 / 0.96	23 / 0.95	21 / 0.94	19 / 0.93	16 / 0.92	14 / 0.91	11 / 0.90
	9.53 [3/8]	15.88 [5/8]	25	8 / 0.99	15 / 0.98	23 / 0.97	30 / 0.96	30 / 0.95	30 / 0.94	30 / 0.93	29 / 0.92	28 / 0.91	27 / 0.90
	6.35 [1/4]	19.05 [3/4]	N/A	8 / 1.00	15 / 1.00	6 / 0.99	N/R	N/R	N/R	N/R	N/R	N/R	N/R
	7.94 [5/16]	19.05 [3/4]	37	8 / 1.00	15 / 1.00	23 / 0.99	27 / 0.99	23 / 0.98	21 / 0.98	19 / 0.98	16 / 0.97	14 / 0.97	11 / 0.96
	9.53 [3/8]	19.05 [3/4]	25	8 / 1.00	15 / 1.00	23 / 0.99	30 / 0.99	30 / 0.98	30 / 0.98	30 / 0.98	29 / 0.97	28 / 0.97	27 / 0.96
8.8 kW [2.5 Ton]	7.94 [5/16]	15.88 [5/8]	31	8 / 0.99	15 / 0.98	23 / 0.96	21 / 0.94	18 / 0.93	15 / 0.91	11 / 0.90	N/R	N/R	N/R
	9.53 [3/8]	15.88 [5/8]	21	8 / 0.99	15 / 0.98	23 / 0.96	30 / 0.94	30 / 0.93	29 / 0.91	27 / 0.90	N/R	N/R	N/R
	7.94 [5/16]	19.05 [3/4]	31	8 / 1.00	15 / 0.99	23 / 0.99	21 / 0.98	18 / 0.98	15 / 0.97	11 / 0.96	8 / 0.96	4 / 0.95	N/R
	9.53 [3/8]	19.05 [3/4]	21	8 / 1.00	15 / 0.99	23 / 0.99	30 / 0.98	30 / 0.98	29 / 0.97	27 / 0.96	26 / 0.96	25 / 0.95	24 / 0.95
	7.94 [5/16]	15.88 [5/8]	30	8 / 0.99	15 / 0.97	20 / 0.94	15 / 0.92	10 / 0.90	N/R	N/R	N/R	N/R	N/R
	9.53 [3/8]	15.88 [5/8]	20	8 / 0.99	15 / 0.97	23 / 0.94	29 / 0.92	27 / 0.90	N/R	N/R	N/R	N/R	N/R
10.6 kW [3 Ton]	7.94 [5/16]	19.05 [3/4]	30	8 / 1.00	15 / 0.99	20 / 0.98	15 / 0.98	10 / 0.97	5 / 0.96	N/R	N/R	N/R	N/R
	9.53 [3/8]	19.05 [3/4]	20	8 / 1.00	15 / 0.99	23 / 0.98	29 / 0.98	27 / 0.97	26 / 0.96	24 / 0.95	22 / 0.94	20 / 0.93	19 / 0.93
	12.7 [1/2]	19.05 [3/4]	10	8 / 1.00	15 / 0.99	23 / 0.98	30 / 0.98	30 / 0.97	30 / 0.96	30 / 0.95	30 / 0.94	30 / 0.93	30 / 0.93
	7.94 [5/16]	22.23 [7/8]	30	8 / 1.00	15 / 1.00	20 / 1.00	15 / 0.99	10 / 0.99	5 / 0.99	N/R	N/R	N/R	N/R
	9.53 [3/8]	22.23 [7/8]	20	8 / 1.00	15 / 1.00	23 / 1.00	29 / 0.99	27 / 0.99	26 / 0.99	24 / 0.98	22 / 0.98	20 / 0.98	19 / 0.97
	1/2 [12.7]	22.23 [7/8]	10	8 / 1.00	15 / 1.00	23 / 1.00	30 / 0.99	30 / 0.99	30 / 0.99	30 / 0.98	30 / 0.98	30 / 0.98	30 / 0.97
12.3 kW [3.5 Ton]	9.53 [3/8]	19.05 [3/4]	28	8 / 0.99	15 / 0.98	23 / 0.97	27 / 0.96	24 / 0.95	22 / 0.94	20 / 0.92	17 / 0.91	15 / 0.90	N/R
	12.7 [1/2]	19.05 [3/4]	14	8 / 0.99	15 / 0.98	23 / 0.97	30 / 0.96	30 / 0.95	30 / 0.94	30 / 0.92	30 / 0.91	30 / 0.90	N/R
	9.53 [3/8]	22.23 [7/8]	28	8 / 1.00	15 / 1.00	23 / 0.99	27 / 0.99	24 / 0.99	22 / 0.98	20 / 0.97	17 / 0.97	15 / 0.96	13 / 0.96
	12.7 [1/2]	22.23 [7/8]	14	8 / 1.00	15 / 1.00	23 / 0.99	30 / 0.99	30 / 0.99	30 / 0.98	30 / 0.97	30 / 0.97	30 / 0.96	30 / 0.96

**Notes:**  
 1) Do not exceed 61 meters linear line length.  
 2) Do not exceed 30 meters vertical separation between indoor and outdoor units.  
 3) \*19.05mm [3/4 in.] vapor line should only be used for 1.5 ton systems; if outdoor unit is below or at same level as indoor unit to assure proper oil return.  
 4) Always use the smallest liquid line allowable to minimize refrigerant charge.  
 5) Applications shaded in light gray indicate capacity multipliers between 0.90 and 0.96 which are not recommended, but are allowed.  
 6) Applications shaded in dark gray are not recommended due to excessive liquid or suction line pressure drop.



Air

Table 2B: Refrigerant Line Sizing Chart (Metric Units) (con't.)

15 SEER Single-Stage Heat Pumps													
Unit Size	Allowable Liquid Line Size mm [in.]	Allowable Vapor Line Size mm [in.]	(-)P14-F	Outdoor Unit ABOVE or BELOW Indoor Unit Equivalent Length (Meters)									
				24-30	31-38	39-46	47-53	54-61	62-69	70-76	Maximum Vertical Separation / Capacity Multiplier		
14.1 kW [4 Ton]	9.53 [3/8]	19.05 [3/4]	0	8 / 0.99	15 / 0.98	23 / 0.96	24 / 0.95	20 / 0.93	17 / 0.92	14 / 0.91	N/R	N/R	N/R
	12.7 [1/2]	19.05 [3/4]	0	8 / 0.99	15 / 0.98	23 / 0.96	30 / 0.95	30 / 0.93	30 / 0.92	30 / 0.91	N/R	N/R	N/R
	9.53 [3/8]	22.23 [7/8]	0	8 / 1.00	15 / 0.99	23 / 0.99	24 / 0.98	20 / 0.97	17 / 0.97	14 / 0.96	11 / 0.96	8 / 0.95	5 / 0.95
	12.7 [1/2]	22.23 [7/8]	0	8 / 1.00	15 / 0.99	23 / 0.99	30 / 0.98	30 / 0.97	30 / 0.97	30 / 0.96	30 / 0.96	30 / 0.95	30 / 0.95
17.6 kW [5 Ton]	9.53 [3/8]	19.05 [3/4]	0	8 / 0.99	15 / 0.97	23 / 0.94	19 / 0.92	14 / 0.90	N/R	N/R	N/R	N/R	N/R
	12.7 [1/2]	19.05 [3/4]	0	8 / 0.99	15 / 0.97	23 / 0.94	30 / 0.92	30 / 0.90	N/R	N/R	N/R	N/R	N/R
	9.53 [3/8]	22.23 [7/8]	0	8 / 1.00	15 / 0.99	23 / 0.98	19 / 0.97	14 / 0.96	10 / 0.95	5 / 0.94	N/R	N/R	N/R
	12.7 [1/2]	22.23 [7/8]	0	8 / 1.00	15 / 0.99	23 / 0.98	30 / 0.97	30 / 0.96	30 / 0.95	30 / 0.94	29 / 0.94	28 / 0.93	27 / 0.92
	9.53 [3/8]	28.58 [1-1/8]	0	8 / 1.01	15 / 1.01	23 / 1.00	19 / 1.00	14 / 0.99	10 / 0.99	5 / 0.99	N/R	N/R	N/R
	12.7 [1/2]	28.58 [1-1/8]	0	8 / 1.01	15 / 1.01	23 / 1.00	30 / 1.00	30 / 0.99	30 / 0.99	30 / 0.99	29 / 0.99	28 / 0.99	27 / 0.98

## Notes:

- 1) Do not exceed 61 meters linear line length.
- 2) Do not exceed 30 meters vertical separation between indoor and outdoor units.
- 3) \*19.05mm [3/4 in.] vapor line should only be used for 1.5 ton systems if outdoor unit is below or at same level as indoor unit to assure proper oil return.
- 4) Always use the smallest liquid line allowable to minimize refrigerant charge.
- 5) Applications shaded in light gray indicate capacity multipliers between 0.90 and 0.96 which are not recommended, but are allowed.
- 6) Applications shaded in dark gray are not recommended due to excessive liquid or suction line pressure drop.





## Performance Data @ AHRI Standard Conditions – Heat Pump

Designated Tested Combination (DTC)												
Outdoor Unit	Air Handler	Total Capacity BTU/H [kW]	Net Sensible BTU/H [kW]	Net Latent BTU/H [kW]	SEER	EER	Indoor CFM [L/s]	47 Degree Heating Capacity BTU/H [kW]	47 Degree COP	17 Degree Heating Capacity BTU/H [kW]	17 Degree COP	Region IV HSPF
RP1518CJ1	RH1T2417STAN	18000 [5.3]	14400 [4.2]	3600 [1.0]	15.00	12.50	650 [305.0]	15700 [4.6]	3.60	9100 [2.7]	2.40	8.20
RP1524BJ1	RH1T2417STAN	24000 [7.0]	16900 [5.0]	7100 [2.1]	15.50	13.00	800 [376.0]	22000 [6.4]	3.70	13500 [4.0]	2.50	9.00
RP1530BJ1	RH1T3617STAN	29400 [8.6]	20800 [6.1]	8600 [2.5]	15.50	13.00	1025 [481.8]	27000 [7.9]	3.70	16600 [4.9]	2.40	9.00
RP1536AJ1	RH1T3617STAN	35600 [10.4]	25100 [7.4]	10500 [3.1]	15.00	12.50	1175 [552.3]	33800 [9.9]	3.66	22200 [6.5]	2.66	9.00
RP1542AC1	RH1T4821STAN	42500 [12.5]	30000 [8.8]	12500 [3.7]	15.00	12.50	1350 [634.5]	40000 [11.7]	3.76	25600 [7.5]	2.60	9.00
RP1542AJ1	RH1T4821STAN	42500 [12.5]	30000 [8.8]	12500 [3.7]	15.00	12.50	1350 [634.5]	40000 [11.7]	3.76	25600 [7.5]	2.60	9.00
RP1548AC1	RH1T4821STAN	47000 [13.8]	33200 [9.7]	13800 [4.0]	15.00	12.50	1500 [705.0]	44500 [13.0]	3.66	28800 [8.4]	2.60	9.00
RP1548AJ1	RH1T4821STAN	47000 [13.8]	33200 [9.7]	13800 [4.0]	15.00	12.50	1500 [705.0]	44500 [13.0]	3.66	28800 [8.4]	2.60	9.00
RP1560AC1	RH1T6024STAN	58000 [17.0]	41000 [12.0]	17000 [5.0]	15.00	12.50	1775 [834.3]	56000 [16.4]	3.76	35600 [10.4]	2.66	9.00
RP1560AJ1	RH1T6024STAN	58000 [17.0]	41000 [12.0]	17000 [5.0]	15.00	12.50	1775 [834.3]	56000 [16.4]	3.76	35600 [10.4]	2.66	9.00

Note: Additional ratings and system match ups can be accessed on MyRheem.com at: <https://my.rheem.com/static/private/ahri/residential.html>  
 Additional ratings and system match ups and downloadable ratings certificates can be accessed from the AHRI website: [www.ahridirectory.org](http://www.ahridirectory.org)

[ ] Designates Metric Conversions

## GUIDE SPECIFICATIONS

### General

#### System Description

Outdoor-mounted, air-cooled, split-system heat pump unit suitable for ground or rooftop installation. Unit consists of a hermetic compressor, composite basepan, an air-cooled coil, propeller-type condenser fan, suction and liquid line service valve, and a control box. Unit will discharge supply air upward as shown on contract drawings. Unit will be used in a refrigeration circuit to match up to a coil unit.

#### Quality Assurance

- Unit will be rated in accordance with the latest edition of AHRI Standard 210.
- Unit will be certified for capacity and efficiency, and listed in the latest AHRI directory.
- Unit construction will comply with latest edition of ANSI/ASHRAE and with NEC.
- Unit will be constructed in accordance with UL standards and will carry the UL label of approval. Unit will have c-UL-us approval.
- Unit cabinet will be capable of withstanding ASTM B117 1000-hr salt spray test.
- Air-cooled condenser coils will be leak tested at 150 psig and pressure tested at 550 psig.
- Unit constructed in ISO9001 approved facility.

#### Delivery, Storage, and Handling

- Unit will be shipped as single package only and is stored and handled per unit manufacturer's recommendations.

**Warranty (for inclusion by specifying engineer)** – U.S. and Canada only.

### Products

#### Equipment

Factory assembled, single piece, air-cooled heat pump unit. Contained within the unit enclosure is all factory wiring, piping, controls, compressor, refrigerant charge R-410A, and special features required prior to field start-up.

#### Unit Cabinet

- Unit cabinet will be constructed of galvanized steel, bonderized, and coated with a powder coat paint.
- All units constructed with louver coil protection and corner post. Louver can be removed by removing one fastener per louver panel.

### AIR-COOLED, SPLIT-SYSTEM HEAT PUMP

#### RP15

#### 1-1/2 TO 5 NOMINAL TONS

#### Fans

- Condenser fan will be direct-drive propeller type, discharging air upward.
- Condenser fan motors will be totally enclosed, 1-phase type with class B insulation and permanently lubricated bearings. Shafts will be corrosion resistant.
- Fan blades will be statically and dynamically balanced.
- Condenser fan openings will be equipped with coated steel wire safety guards.

#### Compressor

- Compressor will be hermetically sealed.
- Compressor will be mounted on rubber vibration isolators.

#### Condenser Coil

- Condenser coil will be air cooled.
- Coil will be constructed of aluminum fins mechanically bonded to copper tubes.

#### Refrigeration Components

- Refrigeration circuit components will include liquid-line shutoff valve with sweat connections, vapor-line shutoff valve with sweat connections, system charge of R-410A refrigerant, and compressor oil.
- Unit will be equipped with filter drier for R-410A refrigerant for field installation.

#### Operating Characteristics

- The capacity of the unit will meet or exceed \_\_\_\_\_ Btuh at a suction temperature of \_\_\_\_\_ °F/°C. The power consumption at full load will not exceed \_\_\_\_\_ kW.
- Combination of the unit and the evaporator or fan coil unit will have a total net cooling capacity of \_\_\_\_\_ Btuh or greater at conditions of \_\_\_\_\_ CFM entering air temperature at the evaporator at \_\_\_\_\_ °F/°C wet bulb and \_\_\_\_\_ °F/°C dry bulb, and air entering the unit at \_\_\_\_\_ °F/°C.
- The system will have a SEER of \_\_\_\_\_ Btuh/watt or greater at DOE conditions.

#### Electrical Requirements

- Nominal unit electrical characteristics will be \_\_\_\_\_ v, single phase, 60 hz. The unit will be capable of satisfactory operation within voltage limits of \_\_\_\_\_ v to \_\_\_\_\_ v.
- Nominal unit electrical characteristics will be \_\_\_\_\_ v, three phase, 60 hz. The unit will be capable of satisfactory operation within voltage limits of \_\_\_\_\_ v to \_\_\_\_\_ v.
- Unit electrical power will be single point connection.
- Control circuit will be 24v.

#### Special Features

- Refer to section of this literature identifying accessories and descriptions for specific features and available enhancements.

**GENERAL TERMS OF LIMITED WARRANTY\***

Rheem will furnish a replacement for any part of this product which fails in normal use and service within the applicable period stated, in accordance with the terms of the limited warranty.

Conditional Parts  
(Registration Required) .....Ten (10) Years

**\*For complete details of the Limited and Conditional Warranties, including applicable terms and conditions, contact your local contractor or the Manufacturer for a copy of the product warranty certificate.**



The new degree of comfort.™

*In keeping with its policy of continuous progress and product improvement, Rheem reserves the right to make changes without notice.*

Rheem Heating, Cooling & Water Heating • 5600 Old Greenwood Road  
Fort Smith, Arkansas 72908 • [www.rheem.com](http://www.rheem.com)

Rheem Canada Ltd./Ltée • 125 Edgeware Road, Unit 1  
Brampton, Ontario • L6Y 0P5



INTEGRATED HOME COMFORT

PRINTED IN U.S.A. 12/19 QG FORM NO. P11-807 REV. 10