

SHERLOCK

102/202 REFRIGERANT MONITOR



Operations Manual

Part # 44-0297

 **GENESIS INTERNATIONAL, INC.**

1040 FOX CHASE INDUSTRIAL DR
ARNOLD, MO 63010
EMAIL:MAIL@GENESIS-INTERNATIONAL.COM
WEB:WWW.GENESIS-INTERNATIONAL.COM

TEL: 636-282-0011
FAX:636-282-2722

TABLE OF CONTENTS

1. SAFETY WARNINGS	5
2. INTRODUCTION	7-8
3. COMPONENT OVERVIEW	
Sherlock 102/202 Control Module	9
Infrared Sensor	10-12
Solid State (CMOS) Sensor	13-14
Ventline Sensor	15
High Pressure Ventline Sensor	15
Electro-Chemical Ammonia Sensor	16
Electro-Chemical Oxygen Depletion Sensor	17
Strobe Light	18
Horn and Strobe Combo	18
Stacked Horn and Strobe Combo	18
AutoAlarm Dialer	19
Remote Alarm and Strobe Combo	19
4. COMPONENT INSTALLATION	20-21
5. WIRING SPECIFICATIONS	
Sensor Wiring	22
Line Voltage Power In	23
Power Output (+12VDC)	23
Alarm Relay Outputs	23
Optional Aux Zone Isolation Alarm Relays	24
Alarm Components Basic Wiring	24
6. HELPFUL HINTS AND STARTUP GUIDE	25
7. KEYPAD BUTTON DESCRIPTION	26
8. DEFAULT SCREEN/ RESPONSE TO ALARM	27
9. MENU STRUCTURE	
Access Menu	28
Status Menu	29-30
Alarm Log Menu	31
Setpoint Menu	32-33
Calibration Menu	34
System Config Menu	35-36
Set Time Menu	38
Test Menu	39
10. MAINTENANCE AND CALIBRATION	
Zero Calibration	40
Measured Gas Calibration	41-43
11. TROUBLE SHOOTING	
CMOS Sensor Trouble Shooting	44
Infrared Sensor Trouble Shooting	45
Electro-Chemical Ammonia Sensor Trouble Shooting	46
12. GLOSSARY	47
13. COMPONENTS PART LIST	48
14. GENERAL WIRING SCHEMATIC	49
15. FIELD WIRING DIAGRAM (BLANK)	50
16. RECOMMENDED ALARM SETPOINTS	51
17. WARRANTY INFORMATION	53

THIS PAGE INTENTIONALLY LEFT BLANK



CAUTION, RISK OF ELECTRIC SHOCK!!!

SHUT OFF ALL POWER TO CONTROL PANEL AND CONTROL CIRCUITS BEFORE OPENING ENCLOSURE DOOR AND PERFORMING SERVICE.



CAUTION, RISK OF ELECTRIC SHOCK!!!

RELAY CONTACTS MAY BE ELECTRIFIED ALTHOUGH CONTROL POWER TO PANEL IS SHUT OFF. ENSURE THAT ALL POWER IS DISCONNECTED BEFORE OPENING ENCLOSURE DOOR AND PERFORMING SERVICE



CAUTION, IMPROPER CONNECTION OF EXTERNAL DEVICES MAY RESULT IN DAMAGE TO CONTROL SYSTEM.

This manual has been checked for accuracy. However, due to new technology being made available, some changes may have been implemented to the control but not necessarily to this manual. If you have any questions regarding any discrepancies, please call Genesis customer service for clarification.

THE SHERLOCK REFRIGERANT GAS MONITOR

The American Society of Heating, Refrigeration, and Air-Conditioning Engineers, Inc Standard *ANSI/ASHRAE 15-2004 Safety Code for Mechanical Refrigeration* states:

8.11.2 Each machinery room shall contain a detector, located in an area where refrigerant from a leak will concentrate, which shall activate an alarm and mechanical ventilation

The International Conference of Building Official *Uniform Mechanical Code, 2000* states:

SECTION 1121 - DETECTION AND ALARM SYSTEM

1121.1 General. Alarm shall be activated whenever the refrigerant vapor Permissible Exposure Limit (PEL) is exceeded. In other than machinery rooms, such systems shall also automatically stop the flow of refrigerant to evaporators within the space and stop the flow of refrigerant in all supply lines leaving the machinery room whenever the refrigerant vapor concentration is detected at or above 50 percent of the IDLH [Immediately Dangerous to Life or Health] or 25 percent of the LEL (lower explosive limit).

The *SHERLOCK* 102, and 202 Refrigerant Gas Monitor was designed to meet these and other requirements.

Monitoring Panel

The *SHERLOCK* 102 and 202 Control Module is an ETL listed, hard wired, permanently mounted electronic control panel that is capable of monitoring the analog output signal of up to two *SHERLOCK* Refrigerant Gas Sensors or one *SHERLOCK* Refrigerant Gas Sensors and one *SHERLOCK* Oxygen Depletion Sensors. The Control Module will activate four Form C SPDT relay contacts based upon the programmed alarm setpoints of each sensor. The relays are referred to as K1, K2 for the first alarm level and K3, K4 for the second alarm level. There is optional zone isolation alarm relay (K5 & K6) for each Sensor. The Control Module can be located in the area to be monitored, or in a separate location, typically outside of the monitored room.

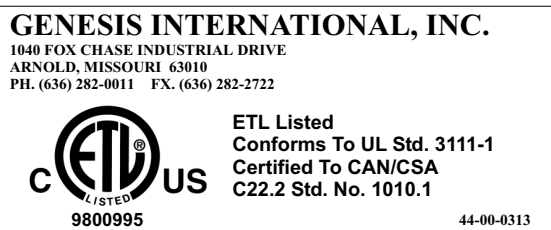

Monitoring Points

Each monitoring point consists of an analog signal generating sensor connected to the control module via discrete, three conductor cable. Each sensor can be mounted up to 1000 feet (longer run with special cable) away in locations where leaked refrigerant is likely to concentrate.

The Sherlock gas sensors are available in three varieties:

Ceramic Metal Oxide Semiconductor (CMOS) or Solid State Sensor

Non-Dispersive, Pyro-Electric Infrared Sensor.

Ammonia & Oxygen Depletion Electro-chemical Sensor.

CMOS or Solid State Sensor

The *SHERLOCK* CMOS (Solid State) Sensor utilizes a Tin-Oxide filament, heated to 400°F, to detect the presence of oxygen molecules within the air. At this temperature, Oxygen molecules cling to the filament. When a molecule of an organic compound or a halogen strikes the filament, it displaces an oxygen molecule thus increasing the resistive value of the filament. This change in resistance is processed by the sensor circuitry to produce an analog output signal, which sent to the Control Module as the sensor reading.

Sensors are available in configurations that detect refrigerant gases by class; CFC/HCFC, HFC and Ammonia. These sensors produce a non-linear output signal that generally corresponds to the concentration of refrigerant in the air.

NOTE: These sensors, due to their nature, are susceptible to detection of non-refrigerant gases and cannot distinguish the presence of different refrigerant gases, only that there is a gas present. The CMOS sensor will detect high concentrations of gasoline, diesel, and propane exhaust and fumes from solvents, paints, cleansers, and others (Please call Genesis Customer Support for more information).

Infrared Sensor

The *SHERLOCK* Non-Dispersive, Pyro-Electric Infrared Sensor utilizes a detection chamber with an infrared light emitter and an infrared Pyro-Electric photo sensor with a filtering lens. The IR sensor will detect the presence of a certain gas by measuring the change in the intensity of light measured by the photo sensor. Each sensor is designed to detect only infrared light of a specific wavelength corresponding to the refrigerant gas to be monitored. This change in light intensity is processed by the sensor circuitry to produce an analog output signal, which sent to the Control Module as the sensor reading.

Sensors are available in specific configurations that detect certain refrigerant gases. Check with Genesis International for a current list a available gas sensors.

These sensors produce a linear output signal that corresponds to the concentration of refrigerant in the air. The Control Module will translate the analog signal and display the readings in Parts per Million values.

Electro-Chemical Ammonia Sensor

The *SHERLOCK* Electro-Chemical Ammonia Sensor utilizes a chemical cell to determine the concentration of Ammonia in the air. The chemical cell produces small chemical reaction with Ammonia molecules, thus producing a voltage drop across the cell. When the concentration of Ammonia goes up, the voltage drop across the cell changes. This change in voltage is

INTRODUCTION

processed by the sensor circuitry to produce an analog output signal, which is sent to the Control Module as the sensor reading. The range is 0-500 ppm.

Oxygen Depletion Sensor

The **SHERLOCK** Oxygen Depletion Electro-chemical Sensor utilizes a chemical cell to determine the concentration of oxygen in the air. The chemical cell produces small chemical reaction with oxygen molecules, thus producing a voltage drop across the cell. When the concentration of oxygen changes, the voltage drop across the cell changes. This change in voltage is processed by the sensor circuitry to produce an analog output signal, which sent to the Control Module as the sensor reading.

Alarm Level Settings

The **SHERLOCK 2-Series** allows you to set a unique Level 1 Alarm Setpoint and delay and Level 2 Alarm Setpoint and delay for each individual sensor. These relays can be active Normally Open (N.O.) or Normally Closed (N.C.). When an Alarm Setpoint is exceeded, after the user set delay, corresponding alarm relays are activated. Each Alarm Setpoint has a programmable Alarm Delay, 1 to 120 minutes. Sensor readings are required to exceed an Alarm Setpoint for the programmed amount of time before the control activates the corresponding alarm relay contacts. For example, if the Alarm Setpoint is 200 and the Alarm Delay is five minutes, the control will enter an alarm condition only if the sensor detects a level of 200 or higher for more than five minutes.

Alarm Indication

All alarms are logged to indicate which sensor went in and out of any of the two alarm levels, the time and date of the alarm. The alarm log stores the last 10 alarms. When a sensor is in alarm, a red alarm light on the front panel will flash and the on-board beeper will sound and the display will show the activated alarm level.

Alarm Relay Contacts

The **SHERLOCK 2-Series** provides two fused SPDT (Single Pole Double Throw) relay outputs for each alarm level that switch positions in the event of an alarm condition. Level 1 Alarm activates #1 (REFR LEAK LEVEL 1) and #2 (REFR LEAK LEVEL 1 SILENCEABLE) relays. Level 2 Alarm activates #3 (REFR LEAK LEVEL 2) and #4 (REFR LEAK LEVEL 2 SILENCEABLE) relays. One alarm relay on each level can be silenced (returned to non-alarm state), (#2 REFR LEAK LEVEL 1 SILENCEABLE / #4 REFR LEAK LEVEL 2 SILENCEABLE) when the ALARM CLEAR button on the front panel is pushed. The other 2 alarm relays will remain active until the alarm condition is cleared. The **SHERLOCK 2-Series** can be programmed so that the alarm is cleared automatically when the air is cleared below the alarm setpoint (UNLATCHED). The relays can also be programmed so the alarm is latched "ON" until the alarm is manually reset. The relays can be configured so the relays are "Energized to Alarm" (where the C-NC contacts open on alarm) or "De-Energized to Alarm" (where the relay is energized during normal operations and the C-NC contacts close on alarm).

Zone isolation Alarm Relays (Factory Installed Option)

Optional zone isolation alarm relay (#5 SENSOR A ZONE, #6 SENSOR A ZONE SILENCE-ABLE, #7 SENSOR B ZONE, #8 SENSOR B ZONE SILENCE-ABLE). Each sensor can be programmed to activate by level 1 or level 1 & 2 alarm. One relay is silenceable and one is non-silenceable. This is a factory installed option and cannot be retro-fitted in the field.

Analog Signal Generator (Factory Installed Option)

The **SHERLOCK 102** and **202** has an optional 4-20 mA analog output generator for each sensor. Either of these signals can be incorporated to any commercially used monitoring and alarming system or in-house Data Management System. This option can only be installed in the factory and cannot be retro-fitted in the field.

Systems Sensor Open Monitoring

The **SHERLOCK 2-Series** constantly monitors the wiring to the sensors. Should any of the activated sensor wires be cut or disconnected, "SENSOR ALARM" will appear on the **SHERLOCK** display, the #1 (REFR LEAK LEVEL 1) and #2 (REFR LEAK LEVEL 1 SILENCEABLE) relays will be activated and the condition is logged.

Setback Alarm Settings

In some locations the sensor may be expected to function in two different environments. For example, the sensor may have to perform in still air (i.e. with the exhaust fan off) and in moving air (i.e. with the exhaust fan on), or the sensor may be used in a location where changes in air quality, perhaps caused by the use of propane powered floor buffers, elevates the sensor readings. The **SHERLOCK 2-Series** provides a feature called SETBACK to accommodate alternate environments under which the sensor would operate. SETBACK provides a second ALARM SETPOINT and a second ALARM DELAY enabling the sensor to perform in this second environment. The **SHERLOCK 2-Series** switches to the second set of parameters when a dry contact (i.e. air flow switch, sail switch or timer switch) closes or on a daily time schedule.

Each sensor can be programmed with one of five SETBACK options:

- 1) No SETBACK
- 2) SETBACK triggered by setback input 1 and the Setback Clock
- 3) SETBACK triggered by setback input 2 only

Each sensor can be programmed with only one SETBACK option; however, different sensors may be programmed to follow different options.

Genesis International Inc. offers a variety of external alarms for office use - A Remote Alarm, Remote Alarm with Strobe, Automatic Alarm Dialer as well as for mechanical room use - a Strobe Light and a combination Horn / Strobe as well as a Stackable Beacon.

SHERLOCK 102 / 202 CONTROL MODULE



**NEMA 1 TYPE ENCLOSURE
(SHER102 & SHER202)**



**NEMA 4X TYPE ENCLOSURE
(SHER102-4 & SHER202-4)**

Listings ETL, Conforms to UL Std. 3111-1
Certified to CAN/CSA
C22.2 Std. No. 1010.1



OVERVIEW

The *SHERLOCK* Monitoring System was designed to monitor up to two SHERLOCK Refrigerant Gas Sensors, activating up to two alarms based upon user defined alarm level setpoints. The SHERLOCK is compliant with ASHRAE 15-2010 and Mechanical Code requirements for refrigerant gas monitoring.

<u>Model #</u>	<u>Nema/IP Rating</u>	<u>Size Inches (mm)</u>	<u>Electrical Category</u>	<u>Pollution Protection</u>
SHER102	1	7.25 x 8.0 x 3.0	I	2
SHER202		(184 x 203 x 76)		
SHER102-4	4X/IP67	12.3 x 15.0 x 8.2	II	3
SHER202-4		(305 x 356 x 178)		

NEMA 1 Compliant Enclosure - This enclosure is intended for indoor use only primarily to provide a degree of protection against contact with the enclosed equipment. The enclosure is not designed to provide protection from water or to be placed in a hazardous environment. Mount only in Pollution Level 2 environments, ie. environmentally controlled offices, control rooms, or environmentally controlled machine rooms.

NEMA 4X Enclosure - This enclosure is intended for either indoor or outdoor use, 0 to 50 °C, to provide a degree of protection against corrosion, windblown dust and rain, splashing water, and hose directed water.

Power Input 100 to 250 VAC, 50/60 Hz, 0.8 Amp

Inputs Up to two Refrigerant Sensors:
or
One Refrigerant Sensor and/or
One Oxygen Depletion Sensor

Outputs Four (4) SPDT, 250V AC / 30V DC,
5.0 Amp Alarm Relays
Optional Zone Isolation Alarm Relays
Optional 4-20mA Analog Signal
Optional RS-485 for GenCom or Modbus

Setback 24 Hour Time Clock
Two Dry Contact Digital Inputs

Alarms Two Alarm Levels, Two SPDT Relay per Level, Fuse On Common Terminal. One relay on each alarm level can be silenceable when in alarm. Optional zone isolation alarm relay for each sensor.

Control Operating Environment

Temperature 32°F To 120°F (0°C To 50°C)
Humidity 0 To 95% RH Non-condensing

Display 2 Line By 16 Characters Alphanumeric
Backlighted LCD display

Keypad 5 Tactile Pushbuttons
Scroll Up, Scroll Down, Alarm Silent/Clear, Select/Edit/Change, Exit Function-Menu

Alarm Indicators

Display Name & Current Reading Of Alarming Sensor
Buzzer Built-in Piezo-electric, 90db @10ft (3.05M), Silenceable
Light Built-in Flashing red Light on front panel

IR SENSOR

(Also see manual 44-0295 IR Sensor (44-0221 Obsolete)

The **SHERLOCK** Non-Dispersive IR Refrigerant Gas Sensor was designed to monitor for the presence of refrigerant gases within an enclosed space. The sensor is mounted within the space to be monitored and connected by cable to a **SHERLOCK** System. The IR sensor is calibrated to a specific refrigerant gas. The IR comes in two Temperature ranges depending upon the monitoring environments: Machine room and Extended for refrigerated applications in NEMA 3R Aluminum (Pictured). Water-tight ABS fiberglass housing for Wash down protection (NEMA 3R) and Stainless Steel enclosure are also available.

The IR Sensor is a reliable method of monitoring for refrigerant gas leaks in environments that have air quality problems. The IR will eliminate many false alarms in environments that contain gasoline, diesel, and propane exhaust and fumes from solvents, paints, cleansers, and others.

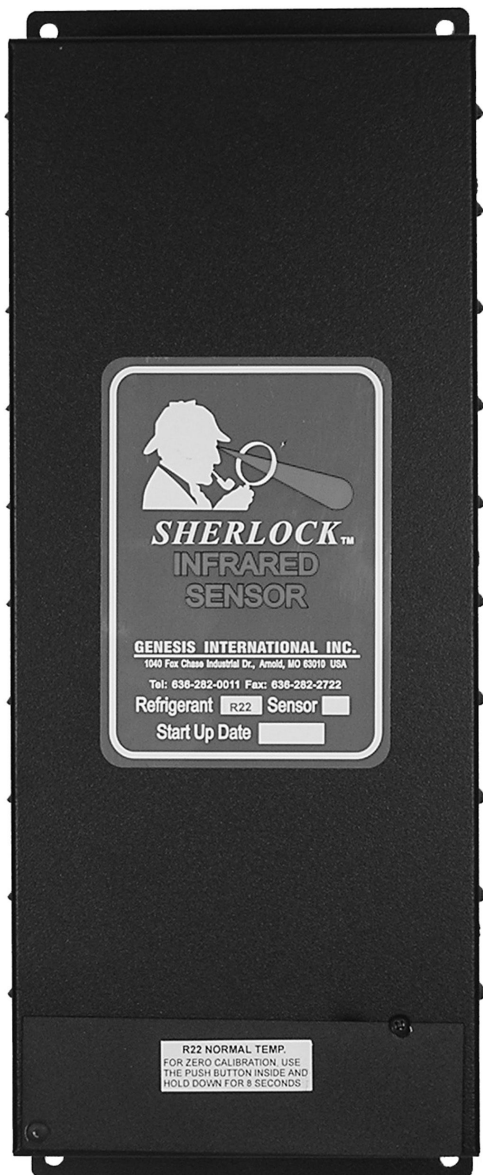

NEMA 3R ALUMINUM HOUSING

ENCLOSURE RATING	NEMA 3R Aluminum, Black Powder Coat
DIMENSIONS Inches (mm)	12.86 x 4.8 x 2.44 (327 x 122 x 62)
OPERATING ENVIRONMENT	
TEMPERATURE	Machine Room 32°-110°F (0°-43.3°C) Extended Temp -40°-110°F (-40°-43.3°C)
HUMIDITY	0 TO 90% RH Non-Condensing
POWER INPUT	12VDC, 0.4 A
EFFECTIVE RANGE	0 to 1000ppm
SENSITIVITY	±1 ppm at 77°F (25°C), 45% RH
RESOLUTION	1 ppm
RESPONSE TIME	Under Than 60 Seconds
CALIBRATION	Every 6 Months
WARM-UP TIME	Readings stabilize in 6 to 7 hrs
LIFE EXPECTANCY	Average of 5 to 7 years in normal environments

AVAILABLE GAS SENSORS (Part Numbers)

Machinery Room/Walk-In Cooler Application

R11 - 60-0057	R12 - 60-0104	R22 - 60-0053
R114 - 82-0260	R123 - 60-0137	R134A - 60-0054
R402A - 60-0231	R404A - 60-0052	R407A - 60-0223
R407C - 60-0214	R407F - 60-0514	R125 - 60-0466
R408A - 60-0184	R409A - 60-0066	R410A - 60-0165
R500 - 60-0067	R502 - 60-0059	R507 - 60-0061
Ammonia/NH ₃ - 600095		

Extended Temperature/Freezer Application

R11 - 60-0058	R22 - 60-0047	R402A - 60-0142
R404A - 60-0051	R408A - 60-0065	R502 - 60-0060
R507 - 60-0062	Ammonia/NH ₃ - 60-0096	

Call factory for list of additional refrigerants

APPLICATIONS

Typical applications include:

Wineries	HVAC Chiller Equipment Rooms
Bakeries	Refrigeration Mechanical Rooms
Refrigerated Rooms	Food Processing Plants



WARNING!!! The infrared sensor is not to be applied into all refrigerated storage applications where other toxic gases are used in the same room. Some installations are not suitable for Infrared technology. Misapplication may result in damage to sensor. Contact the factory for a specific list of approved applications.

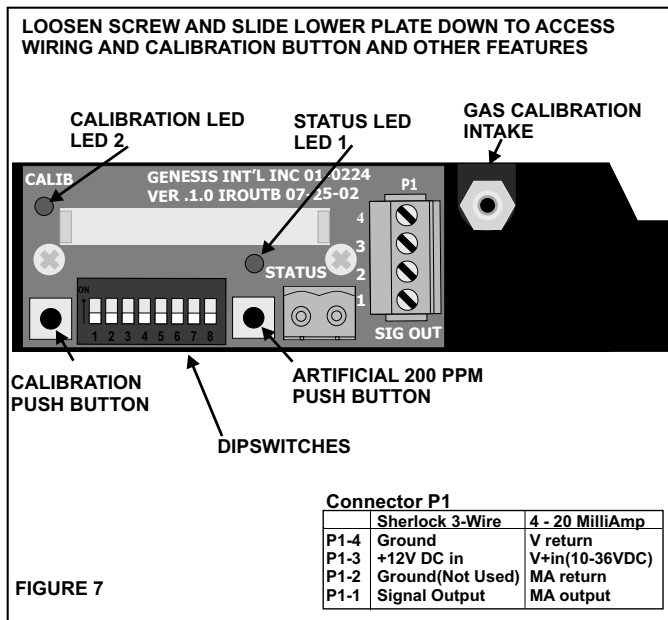

OPERATION

BEFORE CONTINUING, DON'T FORGET TO WRITE DOWN THE START UP DATE ON THE FRONT OF EACH SENSOR. FAILURE TO DO SO COULD VOID THE WARRANTY.

Infrared Sensor components description and use. (Please see 44-00-0295 Infrared sensor Manual for more information)

Dip Switch -- Switches 1 to 8 are set to off at the factory. This is the standard dip switch setting for normal operation

Switches 1, 2, and 3 - Switches 1, 2, and 3 are for communications port addressing.

Switch 4 - For auto long term zero compensation. It will recalibrate up to 10 ppm every 7 days. No more than 100 ppm between manual calibrations. Disable for low level detection.

On zero Compensation SW4 = **OFF**
 Disabled SW4 = **ON**

Switch 5 - For field testing at a set level.

Normal SW5 = **OFF**
 Fixed 200 ppm output SW5 = **ON**

Switch 6 - For factory calibration.

Normal SW6 = **OFF**
 Default Factory setting SW6 = **ON**

Switch 7 - For setting an offset to change from a Sherlock/Wizard control system sensor to a stand-alone sensor BAS signal.

Sherlock/Wizard SW7 = **OFF**
 Standalone (4-20mA) SW7 = **ON**

Switch 8 - Not used

Push buttons - Located just on either side of the DIP Switches.

Push button 1 It is used for testing the sensor with a 200 ppm false signal. Dipswitch 5 can be used for the same function.

Push button 2 It is used for sensor calibration and is used in conjunction with LED 2

Light Emitting Diodes (LED)

LED L1 - LED L1 will indicate if the sensor microprocessor is operating and if the sensor is in test mode. When the microprocessor goes through start-up, it will turn on L1 and keep it on unless switch 5 is on or pushbutton 1 is depressed.

Status	Condition
Off	Sensor is not powered up. Microprocessor detects an error in the sensor hardware. Microprocessor Failure
ON Steady	Sensor is operating properly.
ON Flashing	Switch 5 is set to on or pushbutton 1 is depressed or microprocessor error.

LED L2 - LED L2 is used for zero calibration. When pushbutton 2 is pressed, LED 2 will light after 8 seconds and turn off once the button is released.

Status	Condition
Off	Normal operation
ON Steady	Factory Calibrated Setting. Turn switch 6 off
ON Flashing	Microprocessor error. Call factory.

CALIBRATION

Prior to shipment, all sensors manufactured by Genesis International, Inc. are factory calibrated. The calibration method will set the base level (or Zero Level) and the gain (or Slope). As the sensor gets older or the ambient condition changes drastically, the Zero Level may drift upward or downward. The Gain (Slope) will not normally change.

Adjustments of the Zero Level is necessary to ensure that the Sherlock IR Sensor is reading accurately. This should be done every 6 months. This function can be performed by conducting a Push button at the sensor and Zero Offset Calibration within the Sherlock or Wizard control systems.

PUSH BUTTON -- Located just to the left of the red DIP Switch. **Please follow the directions below before doing the zero calibration on any of our controls.**

1) Make sure the unit is properly wired up and all dip switches are in the off position and allow a minimum of 3 hours warm up time. For low temperature applications, 18 hours is recommended. The ambient temperature should be stable and within the desired operating range. Make sure no refrigerant gas is present during of calibration.

2) Depress and hold down the push button (located to the left of DIP SW1) for at least 8 seconds until the calibration LED red light above the push button lights. Release the push button.

3) The LED red light will go off. If not, make sure switch 6 is off. Consult factory if calibration LED light stays on or keeps flashing after calibration or during normal operation.

4) For Genesis Control, do the Calibration on this sensor at the monitor to eliminate any internal errors. After control calibration, the sensor reading on the unit should be zero. ABS or absolute reading in the control calibration menu will read from 0 to around 20 depending on the control.

IR SENSOR

NOTE: If the sensor is reading greater than 80, the sensor will not calibrate and the display will read “CALIBRATION ERROR”. Check for gas leak around the sensor. If no leak is found, do the calibration on the sensor itself. This process is also called zero offset.

Zero Offset Calibration

Press the EXIT Key. Using the UP/DOWN Arrows, place the Sherlock into the “Access” Menu. Press Select. If the control display shows <DATA ACCESS MODE>, then press the EXIT Key. If not, press the **SELECT** Key, changing the control from <VIEW ONLY MODE> to <DATA ACCESS MODE>. Press the EXIT Key. Using the UP/DOWN Arrows, place the Sherlock into the “Calibration” Menu. Press Select. Using the UP/DOWN Arrows, locate the function <CALIBRATE SENSOR X> where “X” is the sensor being calibrated. Press the SELECT Key. The display should state <CONFIRM CALIBRATE>. Press the SELECT Key. The display should show <CALIBRATION DONE>.

SENSOR EMERGENCY RESET TO ORIGINAL FACTORY SETTING

Sensor Reading not keeping steady

If the sensor reading is floating, ie. not staying at “0”, the sometimes happens when the sensor push button calibration is done before the recommended burn in time of 3 hours, or if there is bad data in the sensor microprocessor, a factory reset may be necessary.

WARNING! FOLLOW INSTRUCTIONS EXACTLY!

- 1) Flip Switch 6 Up, “Factory Calibration”.
- 2) Hold Down Calibration Push Button. If LED is ON, it may go out when the button is pressed. Hold the button down for at least 8 seconds. The LED will come on.
- 3) Release the button.
- 4) Wait 2 Minutes
- 5) Switch Dip Switch 6 Off.
- 6) Disconnect Power From the Sensor.
- 7) Re-Connect Power.
- 8) Wait a **minimum of 3 hours** (more is preferable).
- 9) Attempt the Push Button procedure again.
- 10) Do control calibration

CMOS SENSOR

GENERAL

SHERLOCK CERAMIC METAL OXIDE SEMICONDUCTOR (CMOS) REFRIGERANT GAS SENSOR was designed to detect for the presence of a refrigerant gas within an enclosed space. The sensor is mounted within the space to be monitored and connected by cable to the monitoring device. Each sensor is calibrated to a clean air base zero level at the factory prior to shipment. There are two models of the CMOS sensor, a general one for CFC, HCFC and HFC gases and one for Ammonia. The CMOS Sensor should be utilized as a signal source for a **SHERLOCK** Refrigerant Gas Monitoring System, *Wizard* Evaporator Control or **Walk-In** Monitor & Control.

**** Please Note: Sensor Part Numbers Have Changed for Several Refrigerants, See the Sensor List on the 2nd Page ****



APPLICATIONS

Typical applications include:

Refrigerated Rooms	HVAC Chiller Equipment Rooms
Wineries	Refrigeration Mechanical Rooms
Bakeries	Food Processing Plants

SPECIFICATIONS

ENCLOSURE RATING NEMA1

DIMENSIONS Inches (mm) 4.3 x 2.4 x 1.2 (109 x 61 x 31)

POWER INPUT 12VDC, 250 mAMPs

OUTPUT 0.5 - 5 VDC
(Genesis Control Only)

EFFECTIVE RANGE 20 to 1000 ppm, Control and Refrigerant Gas Type Dependent

ACCURACY ±10% to 50% of reading (Gas Dependent, Could be higher for some newer blends)

REPEATABILITY ±10% when proper calibration and Maintenance is followed.

AVAILABLE GAS SENSORS CFC / HCFC, HFC & Ammonia

OPERATING ENVIRONMENT

TEMPERATURE -25 to 120° F (-32 to 49°C)

HUMIDITY 0 TO 85% RH Non-Condensing

CALIBRATION Every 6 Months

WARM-UP TIME Reading will stabilize after several hours

LIFE EXPECTANCY Average of 3 to 5 years in normal environments

NOTE: These sensors, due to their nature, are susceptible to detection of non-refrigerant gases and cannot distinguish the presence of different refrigerant gases, only that there is a gas present. The CMOS sensor will detect concentrations of gasoline, diesel, and propane exhaust and fumes from solvents, paints, cleansers, and others (Please call Genesis Customer Support for more information.) The stated accuracy is a best case and some refrigerant blends can be off as much as 100% of the Sherlock Control ppm reading.

NOTE: The stated life expectancy for this sensor is 3 to 5 years, however, continued exposure to refrigerants and other gases and humidity and other adverse conditions can severely decrease sensor life.

CMOS SENSOR SELECTION CHART*

Model 82-0101 -- CFC/HCFC/HFC gases

R-22	R-405A(G2015)	R-503
R-123	R-406A(CHG)	R-507A(AZ50)
R-125	R-407A(Klea60)	R-508A(Klea5R3)
R-134A	R-407B(Klea61)	R-508B(SUVA95)
R-143A	R-407C(Klea66)	R-509A(TP5R2)
R-152A	R-407D	R-411A(G2108A)
R-400	R-408A(FX10)	R-411B(G2108B)
R-401A(MP39)	R-409A(FX56)	R-412A(TP5R)
R-401B(MP66)	R-410A(AZ20)	R-413A
R-401C(MP62)	R-410B	R-438A(MO99)
R-402A(HP80)	R-411A(G2018A)	R-503
R-402B(HP81)	R-411B(G2018B)	R-507(AZ50)
R-403A	R-412A(TP5R)	R-508A(Klea5R3)
R-403B	R-413A	R-508B(SUVA95)
R-404A(HP62)	R-438A(MO99)	R-509A(TP5R2)

THE BELOW SENSORS WILL HAVE LIMITED DETECTABILITY USING THE 82-0101 CMOS

R-11	R-32	R-500(AZ50)
R-12	R-113	R-502
R-13	R-124	
R-23	R-142B	

Model 82-0102 -- Ammonia

R-717

*** Please Note: Sensor Part Numbers Have Changed for Several Refrigerants**

CMOS SENSOR

CMOS Sensor Component Description and Use.

Jumper Shorting Pins

The Sherlock CMOS Sensor has a ten pin, five position jumper block, marked as position 0 to 4. This jumper block allows the user to adjust the performance of the CMOS sensor based upon the ambient temperature. The normal, factory set position is position 0.

Once the sensor has "warmed-up" (at least 30 minutes), set the jumper so the sensor reading is between 0 and 80. Once the reading has stabilized, perform the Zero Calibration procedure.

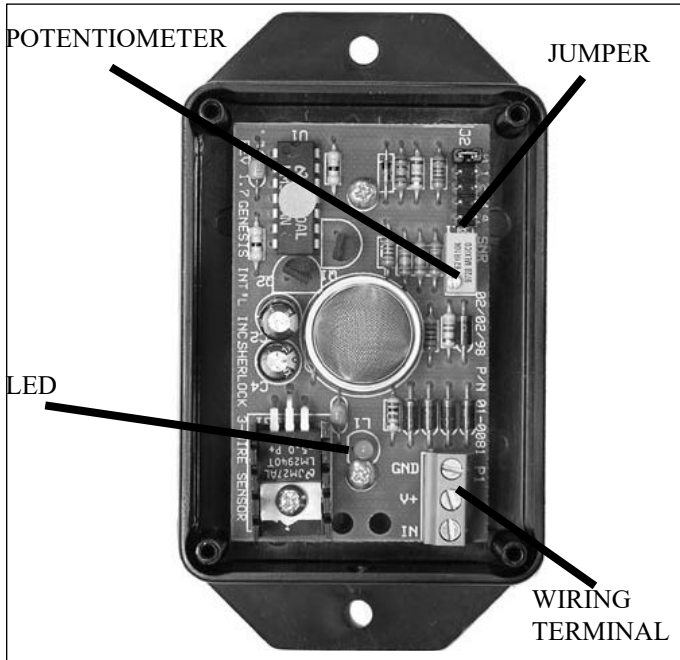

Potentiometers. The Sherlock CMOS Sensor contains a potentiometer used for field calibration procedures.

Light Emitting Diode

LED L1 - LED L1 will indicate whether if the sensor is connected properly and is powered up.

Status	Condition
Off	Sensor is not powered up.
ON Steady	Sensor is operating properly.

Operating Range.

The Sherlock CMOS Sensor has an effective range of 0 to 1000 ppm (gas and control dependant)

0 to 0.3 VDC - Sensor Malfunction

Temperature Adjustment: Jumper Placement

#0	60 to 120 F
#1	50 to 120 F
#2	30 to 80 F
#3	0 to 40 F
#4	-20 to 20 F

Set the jumper for the temperature range the sensor will most likely experience, if needed. **Note: If the application is a cold room environment and the sensor is reading properly on lower numbers, it is okay to leave the jumper there. This is only if the sensor is installed in a cooler or freezer and the system has not yet been turned on.**



NEMA 3R SPLASH PROOF HOUSING

Use only watertight fittings, either conduit fittings or cable retention fittings. Mount conduit on the bottom side of the housing to prevent moisture from dripping on the control board.

MOUNTING INSTRUCTIONS

Sensor Placement

The Sherlock CMOS Refrigerant Sensor must be placed in locations where a refrigerant gas leak is likely to occur or where leaked refrigerant gas is likely to concentrate so as to provide warning of a potentially hazardous condition. Mounting locations are dependent upon the type of application refrigerant.

All mounting locations should be a fixed, well supported wall, pole or frame and in locations that will prevent damage from fork trucks, carts, and other moveable devices.

For Halocarbon refrigerants (heavier than air), such as R11, R22, R123, R-134a, etc..., place the sensor Genesis part number 82-0101(60-0128) 18 to 24 inches off the floor.

For NH₃ Ammonia, (Lighter than air) Genesis part number 82-0102 (60-0129) place the sensor 18 to 24 inches from the ceiling. If circulation in the room is such that an ammonia discharge will continue to move around the room a second sensor can be added and place 5 to 8 feet above the floor for additional monitoring.

Sensor cable shall have the minimum specifications:

For cable runs of 0 to 100 feet -- 22 AWG, Twisted Pair/Triad, Stranded Wire. (Belden 8443 or equivalent)

For cable runs of 100 to 1000 feet -- 18 AWG, Twisted Pair/Triad, Shielded, Stranded Wire. (Belden 8770 or equivalent)

VENTLINE SENSORS



OVERVIEW

The SHERLOCK VENTLINE REFRIGERANT GAS SENSOR (VENTLINE) was designed to detect the presence of high concentrations of refrigerant gas in the vent lines of refrigeration systems. The sensor warns the user to investigate for possible leaks in relief valve or to check the systems for overpressure. The sensor is designed to be installed in refrigeration vent lines and is supplied in a NEMA 3R rated housing with 3/4" NPT female connections.

There are two models of the Ventline Sensor, one for CFC/ HCFC and HFC gases, and one for Ammonia. The Ventline Sensor should be utilized as a signal source for the SHERLOCK 4-SERIES refrigerant gas monitoring system.

Typical applications include:

- Monitoring of HVAC and refrigeration system relief lines

DIMENSIONS	4.3 x 3.5 x 4.0, 109 x 89 x 102 Inches (mm)
ENVIRONMENT	-25 - 120 °F (-30 - 50 °C), 0 - 95% RH non condensing
POWER INPUT	12V DC, 250mA
OUTPUT	0.5 - 5 VDC
DETECTION RANGE	20 to 1000 ppm (gas dependent)
SENSITIVITY	10 % of full scale reading.
CALIBRATION	Every 6 Months
WARM-UP TIME	Readings will stabilize in 6 to 7 hours.
LIFE EXPECTANCY	3 to 5 years in normal environments

NOTE: The Ventline Sensor is calibrated in the same way as the solid State CMOS sensor on the previous page.

OVERVIEW

The SHERLOCK High Pressure Ventline Refrigerant Gas Sensor was designed to detect the presence of high concentrations of refrigerant gas in the vent lines of refrigeration systems. The sensor warns the user to investigate for possible leaks in relief valve or to check the systems for overpressure. The sensor is designed to be installed in refrigeration vent lines and is supplied in a NEMA 3R rated housing with a 1 1/4" NPT female connection. The Ventline Sensor can be utilized as a signal source for the SHERLOCK 4-Series Refrigerant Gas Monitoring System.

DIMENSIONS Inches (mm)

ENCLOSURE	NEMA 3R 6.5 x 4.5 x 5.0 (165 x 114 x 127)
SENSOR HEAD	Nickel Plate 4.0 x 2.0 x 2.25 (102 x 51 x 57) Sensor Opening, 1.25 (31.75) NPT, Female Connection
CABLE	36 (914) Belden #8443, 3-22 AWG
ENVIRONMENT	-25 to 120 °F (-30 to 50 °C), 0 to 95 % RH non condensing
POWER INPUT	12VDC, 250 mAmps
OUTPUT SIGNAL	0.5 to 5VDC (Sherlock)
DETECTION RANGE	30 to 300 ppm (gas dependent)
SENSITIVITY	10 % of full scale reading.
MAX. PRESSURE	300 psi
CALIBRATION	Every 6 Months
WARM-UP TIME	Readings will stabilize in 6 to 7 hours.
LIFE EXPECTANCY	3 to 5 years in normal environments

NOTE: The Ventline Sensor is calibrated in the same way as the solid State CMOS sensor on the previous page.

ELECTRO-CHEMICAL NH3 SENSOR

(Please see the diagrams in manual 44-0377 for more information and the location of components.)

The **SHERLOCK** Ammonia (NH₃) Electro-Chemical Cell Refrigerant Gas Sensor was designed to monitor for the presence of Ammonia refrigerant gases within an enclosed space. The sensor is mounted within the space to be monitored and connected by cable to a **SHERLOCK** System. The Electro-Chemical Sensor Cell comes in a NEMA 3R Grey plastic box. (Pictured) or a NEMA 3R ABS Washdown Housing.

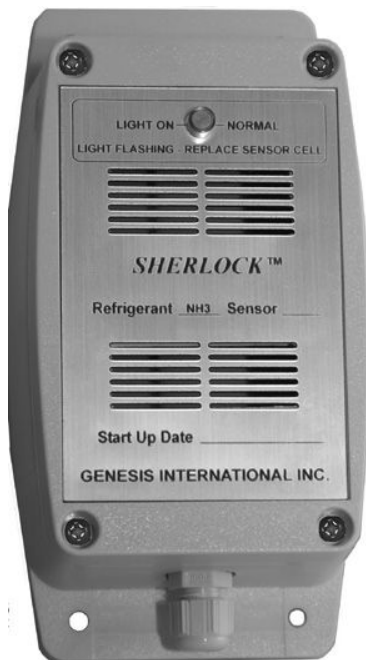

The Electro-Chemical Sensor Cell is a reliable method of monitoring for a low level refrigerant gas leaks in environments that have air quality problems. The Electro-Chemical Sensor Cell sensor will eliminate many false alarms in environments that contain gasoline, diesel, and propane exhaust and fumes from solvents, paints, cleansers, and others (Please call Genesis Customer Support for more information).

The LED on the front of the sensor remains lit when the sensor is operating within parameters. The LED will flash when the sensor element needs to be changed. After changing the sensor element, a push button on the sensor will reset the timer for when the next time the element needs to be changed out.

APPLICATIONS

Typical applications include:
Refrigeration Mechanical Rooms
Refrigerated Rooms
Food Processing Plants



WARNING!!!! The Electro-Chemical sensor will pick up all types of ammonia gas including fumes from household cleaners containing ammonia and is not to be applied into all refrigerated storage applications where other toxic gases are used in the same room. Some installations are not suitable for Electro-Chemical technology. Misapplication may result in damage to sensor. Contact the factory for a specific list of approved applications.

SPECIFICATIONS

ENCLOSURE RATING NEMA 3R ABS Gray Plastic,

DIMENSIONS Inches (mm)

STANDARD 6.88 x 3.58 x 2.13 (175 x 91 x 54)

NEMA 3R ABS 12.0 x 7.0 x 6.0 (305 x 178 x 152)

OPERATING ENVIRONMENT

TEMPERATURE

Machine Room Model 32° - 110°F (0° - 43.3°C)

STANDARD Part Number 82-0460

NEMA 3R ABS Part Number 60-0242

Freezer Room Model -40° - 110°F (-40° - 43.3°C)

STANDARD Part Number 82-0461

NEMA 3R ABS Part Number 60-0243

HUMIDITY 0 - 90% RH Non-Condensing

POWER INPUT 12VDC, 0.1 Amps

OUTPUTS Current Driven

EFFECTIVE RANGE 0 - 500 ppm

SENSITIVITY ±1 ppm at 77°F (25°C), 45% RH

RESOLUTION 1 ppm

RESPONSE TIME Under Than 20 Seconds

CALIBRATION Every 12 Months and after new sensor cell is installed.

WARM-UP TIME Readings will stabilize in 30 Minutes

LIFE EXPECTANCY Average of 24 Months, Sensor Cell can be Field Replaced

COMPONENTS DESCRIPTION AND USE

LED 2 - LED2 is the RED LED that is on the sensor main board. It will flash every second when there is power to the board and it is working properly.

PB1 (PUSHBUTTON 1) - After the new sensor is replaced, PB1 is used to reset the life span timer. Hold the button down for 6 seconds. The light will go out and after 6 seconds, it will flash once. Let go of the push button. The LED should resume flashing every second again. The sensor is ready for use.

POT1 - POT1 is on the upper board and does not need to be changed. On the obsolete board it is the middle potentiometer on the board. It is used to set the new sensor span.

P5 (PLUG CONNECTOR 5) - P5 is a ribbon cable that connects the lower board with the upper board. When replacing a sensor element, this plug is disconnected from the top board socket.

LED3 - LED3 is the 2 pin white plug that connects to the external amber warning LED. When replacing a sensor element, this plug is disconnected from this socket.

OXYGEN DEPLETION SENSOR

(Please see manual # 44-0342 "Oxygen Depletion Sensor" for more information and the location of components.)

The **SHERLOCK** OXYGEN DEPLETION SENSOR (O₂ SENSOR) was designed to monitor concentrations of Oxygen levels within an enclosed space. The sensor is mounted in the space to be monitored and connected by cable to a **SHERLOCK** monitoring control system. Each sensor is factory calibrated to a sea level concentration of 20.9% oxygen clean air base zero level at the factory prior to shipment. The O₂ Sensor should be utilized as a signal source for the **Sherlock** 2-Series or **Sherlock** 4-Series refrigerant gas monitoring systems.

Please Note: When using the Electro-Chemical Oxygen Depletion Sensor, be sure to select for SENSOR TYPE "OXYGEN".



SPECIFICATIONS

SENSOR TYPE	Electrochemical
ENCLOSURE	NEMA 1
Inches (mm)	4.3 x 3.4 x 1.2 (109 x 86 x 31) NEMA 3R Option Available
ENVIRONMENT	50 to 95 °F (10 to 35 °C), 0 to 95 % RH non-condensing
POWER INPUT	12VDC, 250 mAmps
OUTPUT SIGNAL	0 to 5VDC
DETECTION RANGE	15% to 25% Oxygen by volume
SENSITIVITY	0.5 % of full scale reading
CALIBRATION	Every 6 Months
WARM-UP TIME	Readings will stabilize after 3 hours.

LIFE EXPECTANCY

Factory Recommendation
of Replacing the sensor
every 5 years

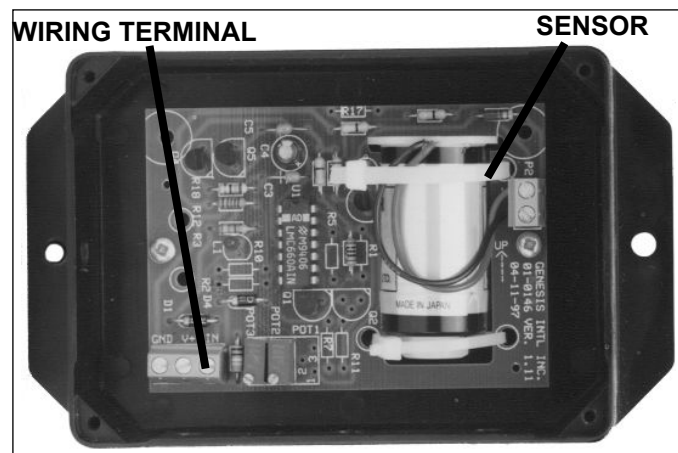

PROPER MOUNTING OF THE ELECTROCHEMICAL SENSOR

NOTE: Sensor module must be mounted so that the sensor (spool-like object) is sitting straight up and down with the wires at the top.

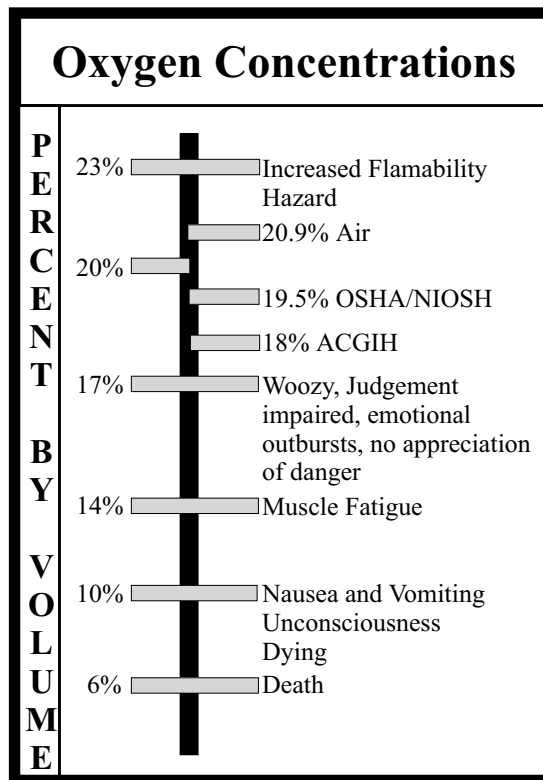

Oxygen Concentration chart with agency guidelines for setting alarm levels and danger limits.

STROBE/ HORN STROBE / BEACON

STROBE LIGHT

Optional Strobe light factory mounted on the *SHERLOCK* 102/202 Monitor

Specifications

- lens color: Blue, Amber or Red
- long-life xenon tube
- protected against polarity reversal
- fully sealed and waterproof
- power output: 1W
- power supply: DC 12V
- current consumption: 150mA
- flash rate: 90-110/min.
- life expectancy: $\pm 3 \times 1000000$ flashes
- operation temperature: -40°F to $+176^{\circ}\text{F}$
- black ABS / acrylic cover
- dimensions: 2.8"(\varnothing) x 2.5"



COMBINATION HORN/STROBE

The Horn/Strobe is a durable indoor/outdoor self-contained siren / strobe combination. The Horn/Strobe has a strong polycarbonate housing and a sturdy aluminum back plate to prevent warping and cracking.

ENCLOSURE RATING Indoor/Outdoor

POWER INPUT 12V DC, 670mA

SOUND OUTPUT 120dB @ 10ft (3.05M)

FLASHING RATE 20 - 100 Flashes/Min

OPERATING ENVIRONMENT

TEMPERATURE -4° - 149°F (-20° - 65°C)

HUMIDITY 0 TO 95% RH Non-Condensing



STACKABLE BEACON

A unique signaling appliance which contains two strobe modules, blue, red or amber, stacked onto a single base unit.

ENCLOSURE: Indoor/outdoor - NEMA 3R

POWER INPUT: 12VDC, 500 ma max.

SOUND OUTPUT: 85 db at 10 ft. (3.05 m)

FLASH RATE: 65 flashes/min

LENS COLORS: Red, blue and/or amber (must be different colors)



STROBE LIGHT/AUTO DIALER / REMOTE ALARM



STROBE LIGHT

Makes any alarm visible during an emergency. High-powered "U" shaped xenon bulb flash is visible for miles.

- HOUSING:** Rain tight; high impact resistant, clear blue, red or amber lens; black, high impact resistance ABS base
- SIZE:** 4" x 3"
- POWER INPUT:** 12VDC, 150ma ±20%
- FLASH RATE:** Approx. 60 to 100 flashes/min.

FAIL SAFE REMOTE ALARM and REMOTE ALARM WITH STROBE

This device will alert the user to an alarm condition it is activated by opening up a self looping dry contact signal. The base has a built-in red led, and blue strobe light to signal an alarm. The unit is equipped with a test and silence button. After the silence action, the buzzer is silent for 30 minutes and will be reactivated if the alarm condition still exists. The remote alarm with strobe comes standard with a wall mountable bracket.

- HOUSING** INDOOR
Remote Alarm
5 1/8" x 5 3/8" x 1 1/2"
Remote Alarm w/Strobe
5 1/8" x 5 3/8" x 5"
- POWER INPUT** Remote alarm - 12VDC 200ma
with strobe - 12VDC, 500ma
wall mounted transformer
- SOUND OUTPUT** 90db at 2 ft
- FLASHING RATE** 60 to 100 flashes/min.
- LENS** High impact resistant, standard blue lens. Red and Amber available



SHERLOCK AUTO ALARM DIALER MODEL 400

When an alarm is detected, the 400 can notify up to four people by making voice phone calls. It will continue to make phone calls until someone responds to the call. The voice messages can be custom recorded, so you get to describe each alarm message that it speaks in your own voice.

A built-in output relay is provided to switch an external device automatically, or manually. You can use it to have a local light or siren trip when an alarm occurs, or even to set off a local alarm when the phone line is cut or unplugged.

DIMENSIONS 7.5 x 2.0 x 8.5 (190 x 51 x 216)
Inches(mm)

BATTERIES (6) 1.5 Volt "D" cell alkaline Telephone Connection: FCC approved RJ-11 plug-in modular connector with 6' cord.

OPERATING TEMPERATURE

Unit should be kept between
32°F - 120°F (0°C - 49°C)

TEMPERATURE SENSING RANGE

-20°F - 150°F (-29°C - 66°C),
with remote temperature sensor.

NRTL listed for compliance with U.L. Standard 1459.



COMPONENT INSTALLATION

COMPONENT INSTALLATION MONITOR AND SENSOR LOCATION

The **SHERLOCK 2-Series** is a permanently mounted device which can be located in any convenient location within 800 feet of each sensor. For single runs under 100 feet, a standard 3 wire, 22 AWG cable should be used. For single runs over 100 feet and below 1000 feet, a shielded, 18 AWG 3 wire cable should be used. Ideally the **SHERLOCK 102/202** should be mounted outside the room being monitored and wired back to a circuit breaker panel. This way the user can check the room conditions without putting themselves in any danger.

Any location for the **SHERLOCK 2-Series** and the sensors must be free from contact with the elements such as steam, water, oil, rain or snow.

The monitor should be kept within a temperature range of 32°F and 120°F. While the IR sensors can operate in a range of -45°F to 120°F. For low temperature models, consult the factory.

Sensor Placement.

The **SHERLOCK** Refrigerant Gas Sensor must be placed in locations that a refrigerant gas leak is likely to occur and where leaked refrigerant gas is likely to concentrate so as to provide warning of a potentially hazardous condition. Mounting locations are dependent upon the application and monitored refrigerant gas.

All mounting locations must be a fixed, well supported wall, pole or frame. Sensors must be placed in locations that will prevent damage from fork trucks, carts, and other moveable devices.

For Halocarbon refrigerants, such as R11, R22, R123, etc..., place the sensor 18 to 24 inches off the floor. For Ammonia, place the sensor 18 to 24 inches from the ceiling.

HVAC/Refrigeration Machinery Room -- Prior to placement of the Refrigerant Gas Leak Sensors, the room air currents need to be determined. Air currents can be determined through the use of smoke candles or any other accepted field-expedient method. The air currents of every potential condition should be determined.

Exhaust Fan On -- The air currents with the machinery room exhaust fan must be determined. Identify locations that are "downwind" of the potential leak source. Located one sensor near the air intake duct of the exhaust fan, but not directly in the duct so the sensor is not subject to the full force of the duct air.

Exhaust Fan Off -- In applications where the machinery room exhaust fan can be shut off, identify air currents of the machine room with the fan off. Locate a position "downwind" of the potential leak source with the fan off. This location may be omitted if the exhaust fan is to be operated continuously.

Refrigerated Room -- Determine the direction of the discharge air from the evaporator coil.

Halocarbon Refrigeration Systems -- Mount the sensor on a wall near the return air vents of the evaporator coil or

within between ten to twenty feet of a doorway exiting the room to a space. Also 18 to 24 inches above the finished floor. Use of a "J" box or some other form of protection for the sensor may be necessary.

Ammonia Refrigeration Systems -- Mount the sensor on a wall in the downwind air path of the discharge air, at least 20 feet or more from the coil or on the wall on the opposite side of the room. 18 to 24 inches from the ceiling. Do not place the sensor closer than 10 feet from the coil or directly in the discharge air path to avoid temperature fluctuations due to defrost and violent air circulation.

Mounting

The sensor must be mounted with the wire terminal blocks oriented to the lower right and the sampling chamber in a vertical position. Failure to mount the sensor in this fashion may result in false or inaccurate readings and can allow moisture to enter the housing and destroy the sensor.

Halo-Carbon, NEMA 1/Ammonia, R123, NEMA 1

Wall Mount. Use locally available wall mounting hardware, such as molly-bolts or toggle bolts, to firmly affix the sensor to the wall. The sensor can be mounted using the available screw holes or a combination of the buttonhole and the two bottom screw holes.

Pole Mounting. The sensor can be mounted to a support pole by utilizing Uni-Strut C braces. Attach the C-braces to the back of the housing, perpendicular to the sensing chamber direction. Attach clamps to the C-brace and run stainless steel band straps around the pole and through the straps.

All Sensors, NEMA 3R

Wall Mount. Use locally available wall mounting hardware, such as molly-bolts or toggle bolts, to firmly affix the sensor to the wall. The sensor should be mounted using the mounting feet mounted on the back of the housing. Ensure that all four sets of mounting feet are accessible. Hold down the mounting feet with the locally available wall mounting hardware.

Pole Mounting. The sensor can be mounted to a support pole by utilizing Uni-Strut type C braces. Attach the C-braces to the back of the housing, perpendicular to the sensing chamber direction. Attach clamps to the C-brace and run stainless steel band straps around the pole and through the straps.

All access holes must be drilled by the installation personnel.

Use only watertight fittings, either conduit fittings or cable retention fittings. Mount conduit on the bottom side of the housing to prevent moisture from dripping on the control board.

The sensors should be located as close to potential leaks as possible. Refrigerants that are heavier than air will tend to settle at the lowest point. Where there is a ready flow of air, a leak will mix with the air and flow with the air stream. Under certain circumstances the best sensor location may require some experimentation; however, we suggest the following sensor locations:

COMPONENT INSTALLATION

Machine rooms with cycling exhaust fans:

Position the sensor about waist high, below the fan. DO NOT mount the sensor in the fanhousing. The sensor setback should be assigned to any sensors mounted in a high air flow path. A dry contact from the fan relay or a sail switch will be needed to switch the **SHERLOCK 2-Series** to the SETBACK mode.

Refrigeration pits piping troughs:

Position the sensor at least 12 inches above the lowest point. If the piping trough is subject to the effects of the machine room exhaust, use the sensor SETBACK feature.

Return air duct to the HVAC system:

Most any location in the main return duct will pick up leaks in the sales area of the store. See **NOTE** below.

Ammonia, being lighter than air, will rise from the source; therefore, ammonia sensors should be mounted above and down wind from the source. Since halocarbon based refrigerants are heavier than air, the sensors detecting the presence of these refrigerants should be located low and down wind from a potential leak.

NOTE: When the sensor are mounted in an area that has air of high velocity, measures must be taken to prevent the sensor from being cooled while still allowing the sensor to sample the air. One method is to mount the sensor inside a 3" diameter by 9" length plastic sewer pipe. A second method is to mount a baffle in the air stream just ahead of the sensor. Air flow across the sensor should never exceed 2 feet per second.

WARNING: Sensors will be damaged by liquids. Mount the sensors away from possible contact with any liquid.

Cable Runs.

All cabling must avoid running parallel to high voltage (48VDC or greater) or any AC voltage wiring. Cable must be greater than 12 inches from high voltage wiring or conduit. Avoid running cable near all inductive loads, such as motors, fluorescent fixtures, transformers. Depending upon local codes, sensor cabling may be run loose or be placed into conduit used exclusively for low voltage control wiring.

Sensor cable shall have the minimum specifications:

SOLID STATE SENSOR

For Wiring Runs of 0 to 100 ft

Twisted, Triad (3-wire) - 22 AWG
Belden part number 8443 or 9407 (For shielded applications - 9363. For Plenum installations - 83395)

For Runs 100 to 1000ft

Shielded, Twisted Triad (3-wire) - 18 AWG
Belden part number 8770 (For Plenum installations- 83335)

INFRARED SENSOR

For Wiring Runs of 0 to 1000 ft

Shielded, Twisted, Triad (3-wire) - 18 AWG
Belden part number 8770 or 9407

Cable wire from other manufacturers with the same specifications and ratings can also be used.

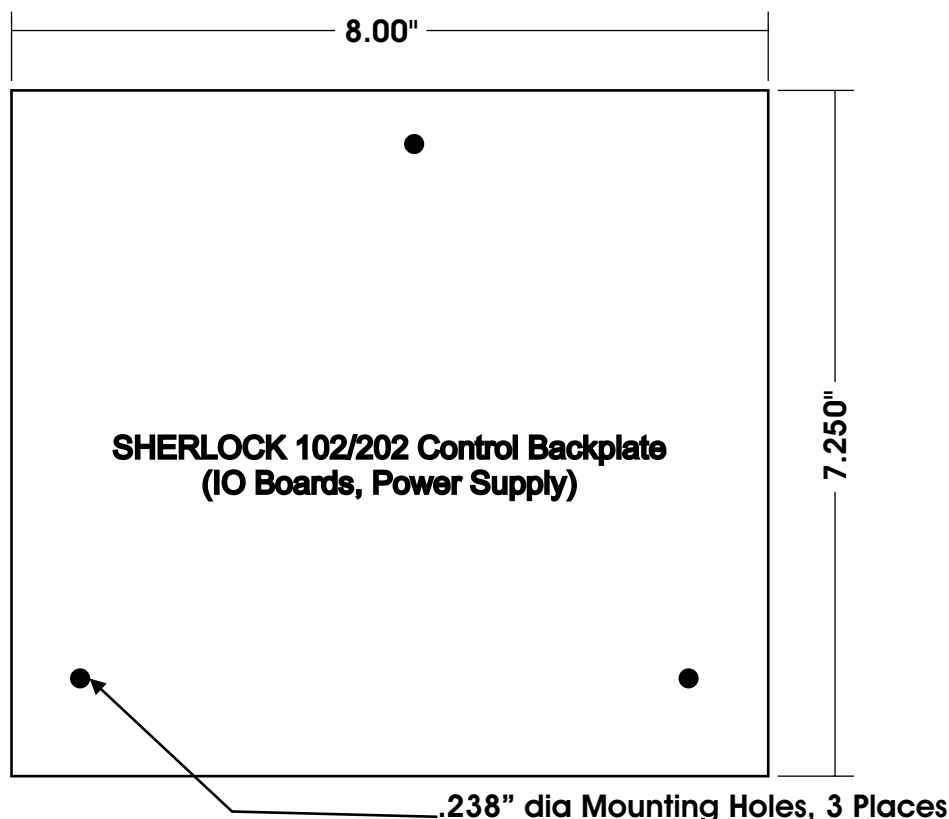

WIRING

SENSOR WIRING

The sensors will not work if improperly wired and may be damaged if wired improperly. We suggest using a three-wire color-coded cable for identification. For consistency, connect the black wire to GND on the sensor as well as the SHERLOCK 2-Series, the red wire to V+ and the green/white wire to IN (i.e. match the same color wire with the same input/output identity). The sensor covers are connected to the housing using either plastic snap-on connections or screws. **Always replace the cover after maintenance!. Do not run the sensor wire near power lines or high voltage wiring, otherwise control may act erratically!!**

SENSOR WIRE TECHNICAL SPECIFICATIONS

SOLID STATE SENSOR

For Wiring Runs of 0 to 100 ft

Twisted, Triad (3-wire) - 22 AWG
Belden part number 8443 or 9407 (For shielded applications - 9363. For Plenum installations - 83395)

For Runs 100 to 1000ft

Shielded, Twisted Triad (3-wire) - 18 AWG
Belden part number 8770 (For Plenum installations - 83335)

INFRARED SENSOR

For Wiring Runs of 0 to 1000 ft

Shielded, Twisted, Triad (3-wire) - 18 AWG
Belden part number 8770 or 9407

Cable wire from other manufacturers with the same specifications and ratings can also be used.

SHERLOCK 102/202 WIRING

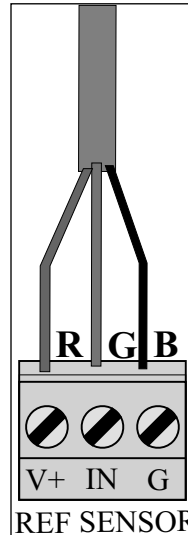

SHERLOCK 102 & 202 WIRING - (Refer to 44-0221 or 44-0295 Infrared Refrigerant Gas Sensor Manuals and 44-0283 Solid-State Sensor Manual for more information about sensor wiring and configuration.)

Wiring diagram for the Sherlock 102, one sensor control and Sherlock 202, two sensor control. Remove the 4 screws holding the faceplate to the housing to access the wiring screw terminals for the sensor at the top of the board and dry contact relays located on the bottom of the board. Follow the silk-screen directions also located on the back of the control faceplate.

SHERLOCK 102/202 TERMINAL CONNECTION DIAGRAM 44-0317D

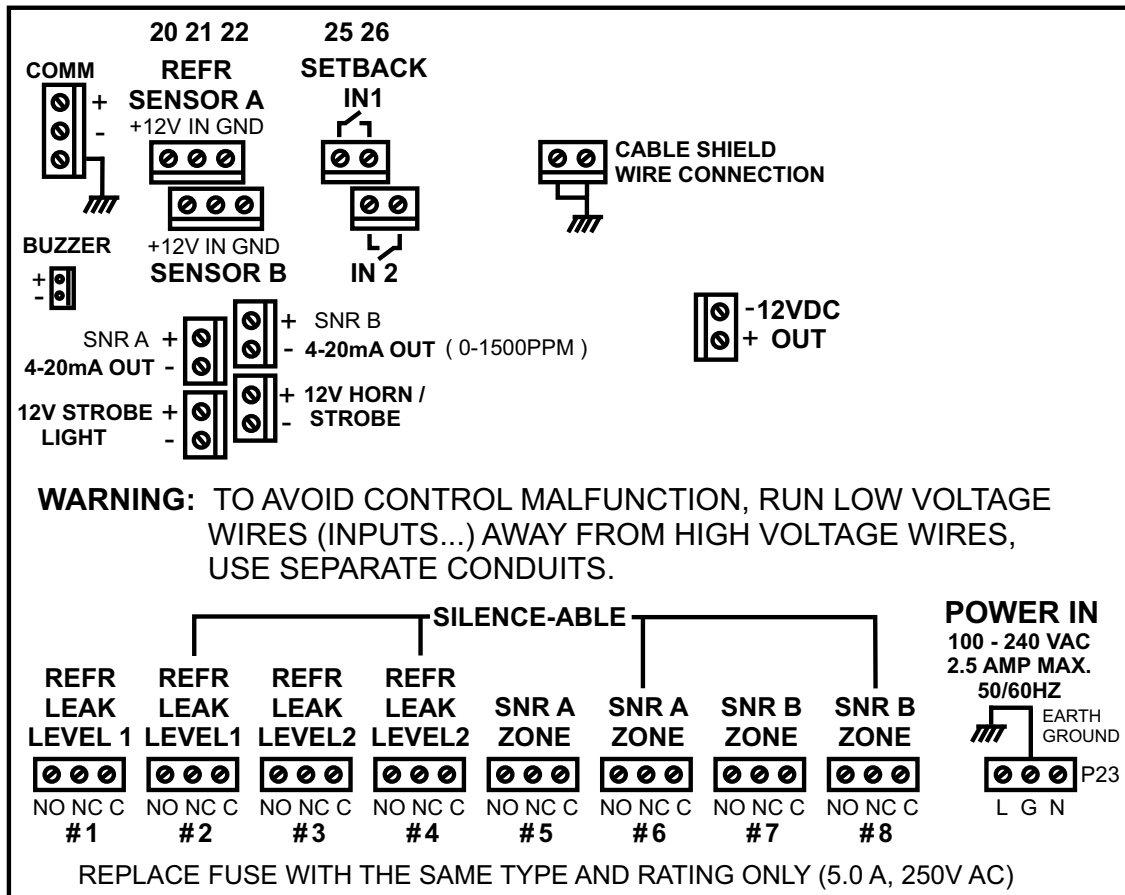

UN-PLUGGABLE MAIN CONNECTOR

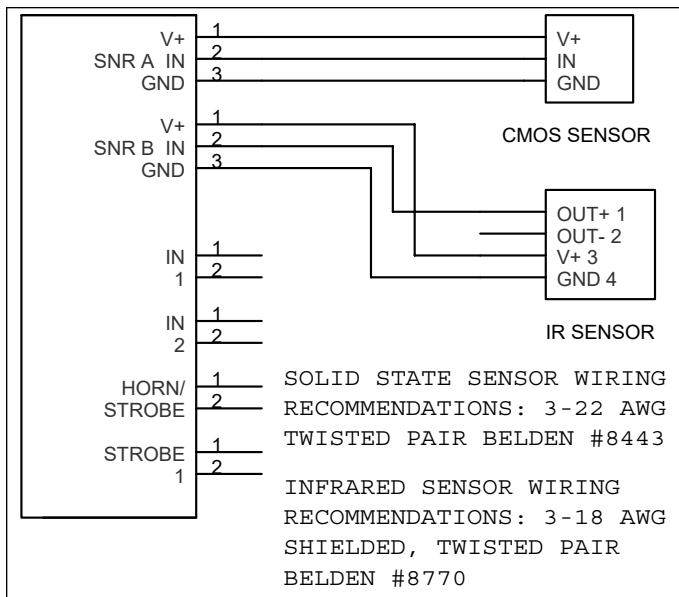

SOLID STATE & INFRARED SENSOR WIRING DIAGRAM
 (NOTE: Either sensor can be wired to either sensor "A" or Sensor "B" input)

POWER TERMINAL - INPUT

LINE VOLTAGE CONNECTIONS

For the **SHERLOCK** 102/202, the power input needs to be between 100 VAC and 240 VAC (Universal voltage) with a maximum current of 0.8 Amps. Bring the power into the control and connect it as it appears on the power terminals labeled at the bottom of the control.

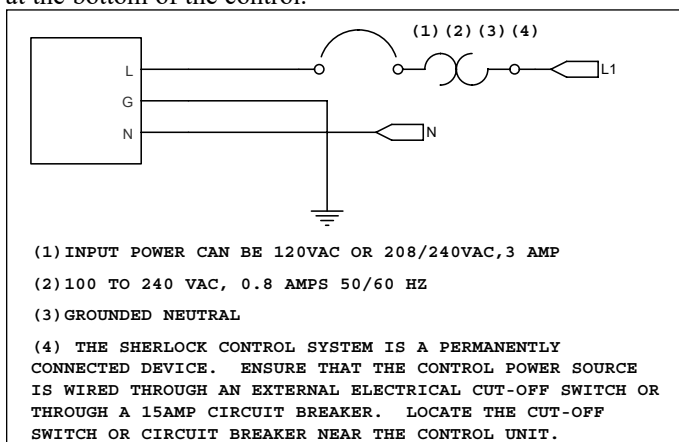

POWER INPUT DIAGRAM

Connections must utilize wire with a minimum insulation value rating of 300 VAC.

NOTE: The **SHERLOCK** 102/202 Control System is a Permanently Connected device. Ensure that the control power source is wired through an external electrical cut-off switch or through a 15 Amp circuit breaker. Locate the cut-off switch or circuit breaker near the control unit.

GROUNDING REQUIREMENTS

The Earth Grounding Terminal on the Input Power Terminal must be grounded in accordance to NEC and UL requirements. Connect the grounding to the G Earth Grounding Connection.

HORN/STROBE, STROBE - OUTPUT

OUTPUT (+12VDC, RETURN) VOLTAGE CONNECTIONS

These terminals are supplied to power only Genesis International, Inc. supplied alarm components. These are:

SHERLOCK STROBE LIGHT

SHERLOCK HORN AND STROBE ASSEMBLY

In general, to power the 12V DC alarm components when alarm occurs, connect the +12VDC supply side to the alarm components through the alarm relays and connect the return path together. In most cases, the alarm component wiring is application specified, please consult the application engineer.

Installation Requirements

- 1) Total current consumed by these alarm components and sensors must not exceed 3.0 Amps at 12VDC output. Refer to component specification for their current ratings.
- 2) The equipment connected to this terminal shall have no live, accessible parts.
- 3) The wire used to connect these devices to the Sherlock Monitoring System shall have, at the minimum, an insulation rating of 300VAC.
- 4) The wiring connection at the device connections shall not be grounded.

ALARM RELAY OUTPUTS

The Alarm Relay Outputs on the *2-Series* are a set of two Single Pole Double Throw (SPDT) alarm relays for each alarm level: K1 and K2 for alarm level 1, K3 and K4 for alarm level 2, Optional Auxilliary Zone Isolation Alarm Relays for each sensor can be factory ordered. Typical uses are:

K1/K2 Lower Alarm Level - Normally indicates the "Permissible Exposure Limits (PEL)" conditions. Connect to an audio-visual alarm and the Building Automation System or an alarm dialing system.

K3/K4 High alarm function - Normally indicates 50% of the "Immediate Danger to Life and Health (IDLH)" levels. Connect to an audio/visual alarm and Emergency Ventilation System.

Alarm schemes **K1/K2** can be configured as a "fail-safe" alarm scheme where the relay is "energized" (Opening the NC contact) during non-alarm conditions and "de-energized" (Closing the NC contact) during alarm conditions. This scheme will allow a alarm signal to be produced if the Sherlock system were to fail. Note that **K2** and **K4** are silenceable alarm relays that can be silenced by the Alarm Silent Button at the front panel when in alarm. Each relay circuit is connected via screw terminals. Each circuit is a dry contacts signal with a 5.0 Amp Time Lag fuse connected to the common leg.

Optional zone isolation alarm relay (**K5** through **K8**) for each sensor can be programmed to activate by level 1 or level 1&2 alarm. **K6/K8** are silenceable and **K5/K7** are non-silenceable. *This is a factory installed option and cannot be retro-fitted in the field.*

WIRING

ALARM INDICATION WIRING DIAGRAMS.

The Sherlock 102/202 is equipped with a Horn/Strobe and Strobe light Output. The total of these two outputs should not exceed 1.0 Amp. This connection is a global alarm and will activate on alarm level one. The output labeled Horn/Strobe is silenceable and the one labeled strobe will not silence until the alarm has cleared.

Another way of controlling alarm outputs is by using the dry contact relays on the bottom of the control board. They give you the option of having 2 alarm levels and 2 relays for each alarm level, One relay per alarm level is silenceable with the press of a button. Each individual relay fuse is rated at 3 Amps. There is also 4 optional relays for 2 zone isolation, so individual audible/visual alarms can be keyed to one specific sensor. If the relays are used, then an external power supply is needed. The onboard 12VDC power can only handle one (1) Horn/Strobe. If more are required, an Auxiliary power supply that can be purchased from Genesis must be used.

There is also a factory installed option of communicating with a Building Management System via a 4-20 milliamp signal.

For more examples, see the wiring diagrams section at the back of this manual.

STROBE LIGHT

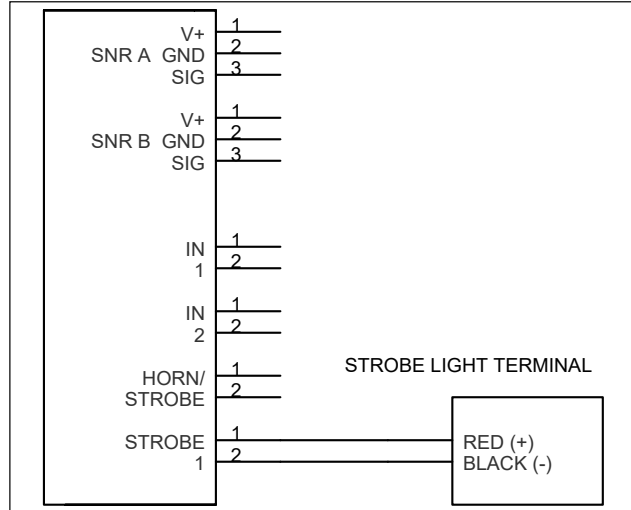

TWO LEVEL MULTI-COLOR STACK BEACON WITH HORN BASE

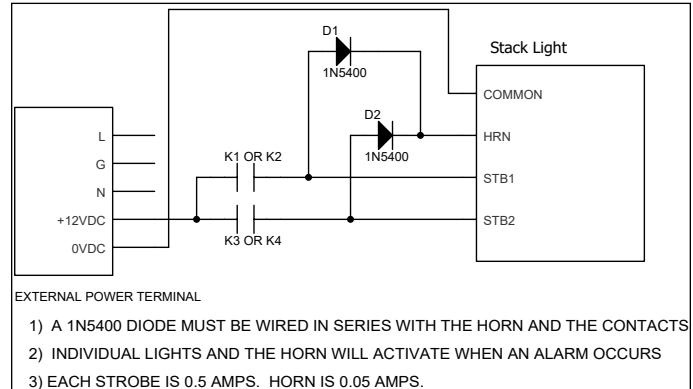

HORN STROBE

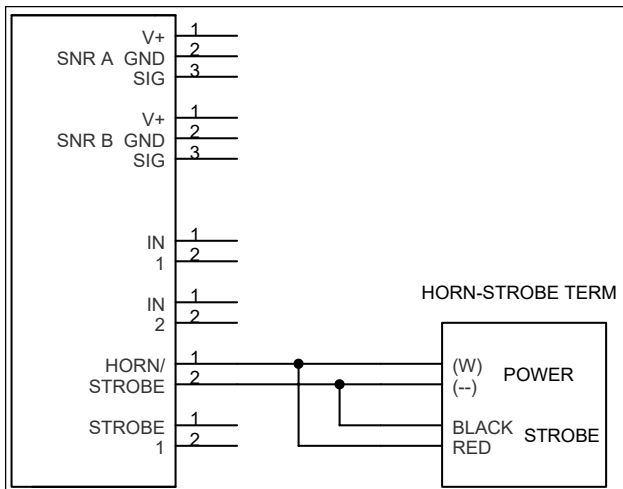

HORN STROBE WITH SILENCEABLE HORN

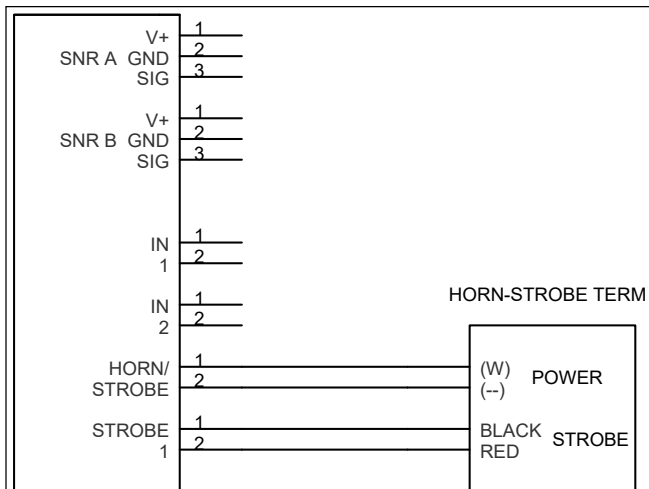

REMOTE ALARM AND ALARM WITH STROBE AUTO ALARM DIALER BUILDING AUTOMATION SYSTEM

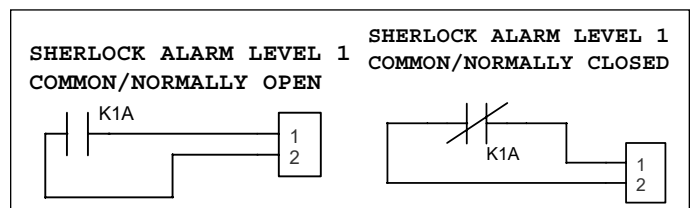

OPTIONAL ANALOG OUTPUT SIGNAL GENERATOR

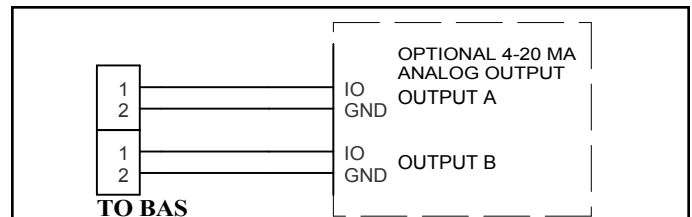

4 - 20 MA OUTPUT MAPPING EQUATION

$$MA = PPM \text{ Reading} * 0.0078125 + 4$$

TEST POINTS

0 PPM = 4.0 MA	500 PPM = 7.90 MA
100 PPM = 4.78 MA	800 PPM = 10.25 MA
250 PPM = 5.95 MA	1000 PPM = 11.81 MA

HELPFUL HINTS AND STARTUP GUIDE

When the monitor is first turned on, it will count down from 90 seconds in order to warm up the sensors. Allow the sensors to run for at least two hours after the initial start up to read accurately.

The Control must be put into ALL ACCESS MODE to make changes in the **SYSTEM CONFIG MENU**. The Control must be put into IN CHANGE MODE to make changes in other menus.

TEST RELAY MENU is useful to check out the proper wiring connection between the audio and visual alarming devices and the relay outputs.

For the initial start up, begin with the **ACCESS MENU**, set the Control to ALL ACCESS MODE, enable sensors in **SYSTEM CONFIG MENU**, modify setpoints in **SETPOINT MENU** and then set the clock in **SET CLOCK MENU**. When the sensor reading is stable (2 hours), calibrate the sensors in the **CALIBRATION MENU**.

The monitor has an internal buzzer in addition to a optional strobe light that can be mounted on the monitor. The buzzer can be silenced during an alarm condition by pushing any buttons on the Control. However the strobe light if installed will remain active as long as alarm level 1 is activated.

The K2 and K4 alarm relay can be silenced using the Alarm Silent Button on the front panel. During an alarm condition, pressing this button will silence these relays (returned to non-alarm state). Keep this in mind when wiring the relays. If you do not want that output to be silenced, do not wire that output to the K2 or K4 relay (i.e. Do not wire the exhaust fans to the K2 or K4 relay.). If the SYSTEM is in CHANGE MODE, pressing the Alarm Silent Button again within ten seconds will clear the alarm. The alarm can also be cleared in ALARM MENU.

The K3/K4 relay for level 2 alarm has a programmable alarm clear delay. If the alarm condition automatically cleared for level 2 alarm. The delay timer starts counting down. The relays will be de-activated after the count down. It can be programmed from 2 to 240 minutes.

The K1/K2 can be programmed to energize in an alarm condition (N.O.) or de-energize in an alarm condition (N.C.). If N.C. mode is selected, power loss to the control will activate the alarm contact.

Each alarm level has its own latching feature. Therefore if the user would like for alarm levels 1 to reset itself but have alarm level 2 be manually reset, they can program it this way.

All the menus and sub-menus wrap around.

The alarm delays are measured in minutes.

An alarm cannot be silenced while in a menu or a submenu.

The time in the control is military time: i.e. 11:00 a.m. = 11:00 and 11:00 p.m. = 23:00.

The display backlight will always be on.

KEYPAD / MENU STRUCTURE

KEYPAD DESCRIPTION

EXIT	Takes the user out of a sub-menu to the previous sub-menu or main main menu or abort changes.
SELECT/CHANGE	Enters the user into a sub-menu, allows the user to change a value or accepts a value.
UP/DOWN	Change values or settings, move around menu or sub-menu.
ALARM SILENT/CLEAR	When in alarm, pressing this button once silence the alarm, pressing it again within 10 seconds to clear the alarm. Alarm can only be cleared when the Control is in CHANGE MODE. This button is not active in MENUS and SUB-MENUS.

BASIC MENU STRUCTURE

ACCESS MENU	Allow the user gain access to the control. This is a program protections feature.
STATUS MENU	Allows the user to view the system setup, settings, version number, etc.
ALARM LOG MENU	Allows the user view the alarm logs.
SETPOINT MENU	Allows the user to change the setpoints, alarm delays, and setback levels for each sensor.
CALIBRATION MENU	Allows the user to view the raw (ABS) value for each sensor and zero each sensor.
SYSTEM CONFIG MENU	Allows the user to activate sensors, activate setback, activate alarm action (N.O. / N.C.), latching feature, enable day light saving, communications and clear the alarm log or the memory.
CLOCK MENU	Allows the user to set the time, and date (day/month/year).
TEST RELAY MENU	Allows the user to test the relays on or off. A method to check the wiring connections between relay outputs and their alarming devices.

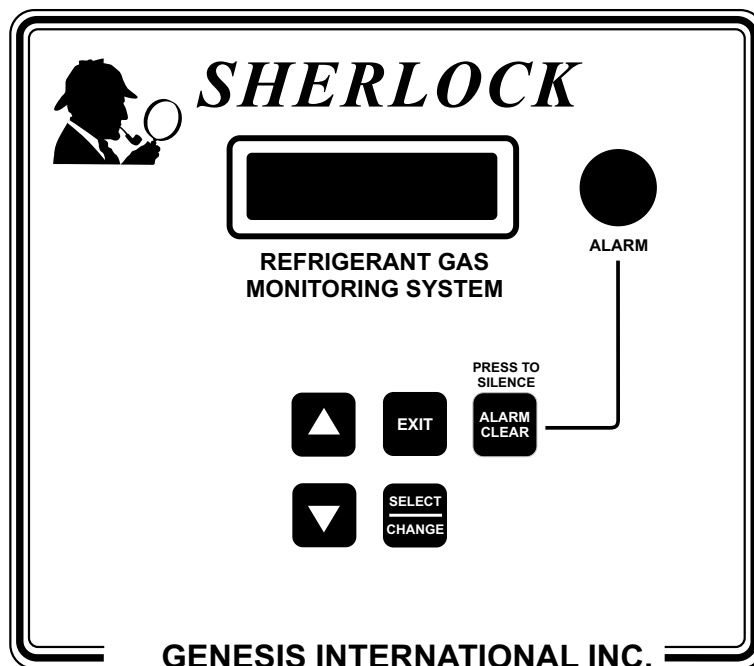

DEFAULT SCREEN / ALARM RESPONSES

DEFAULT SCREEN

The display is a 2 rows by 20 characters backlighted liquid crystal display. When the Control Module is first powered up, the unit will display its initialization screens. Thereafter, the reading and the setpoints of each enabled sensor are shown in alternating fashion every three seconds. If no sensor is enabled, the "TIME" screen will be the only screen shown. If the Control is in alarm, the cause of alarming on each sensor and the alarming level are shown. For those sensors that are in alarm, the correspondent alarm lights on top of the display will be on.. When in MENUS and if no button is pressed for fifteen minutes, the Control will return to the DEFAUT SCREEN

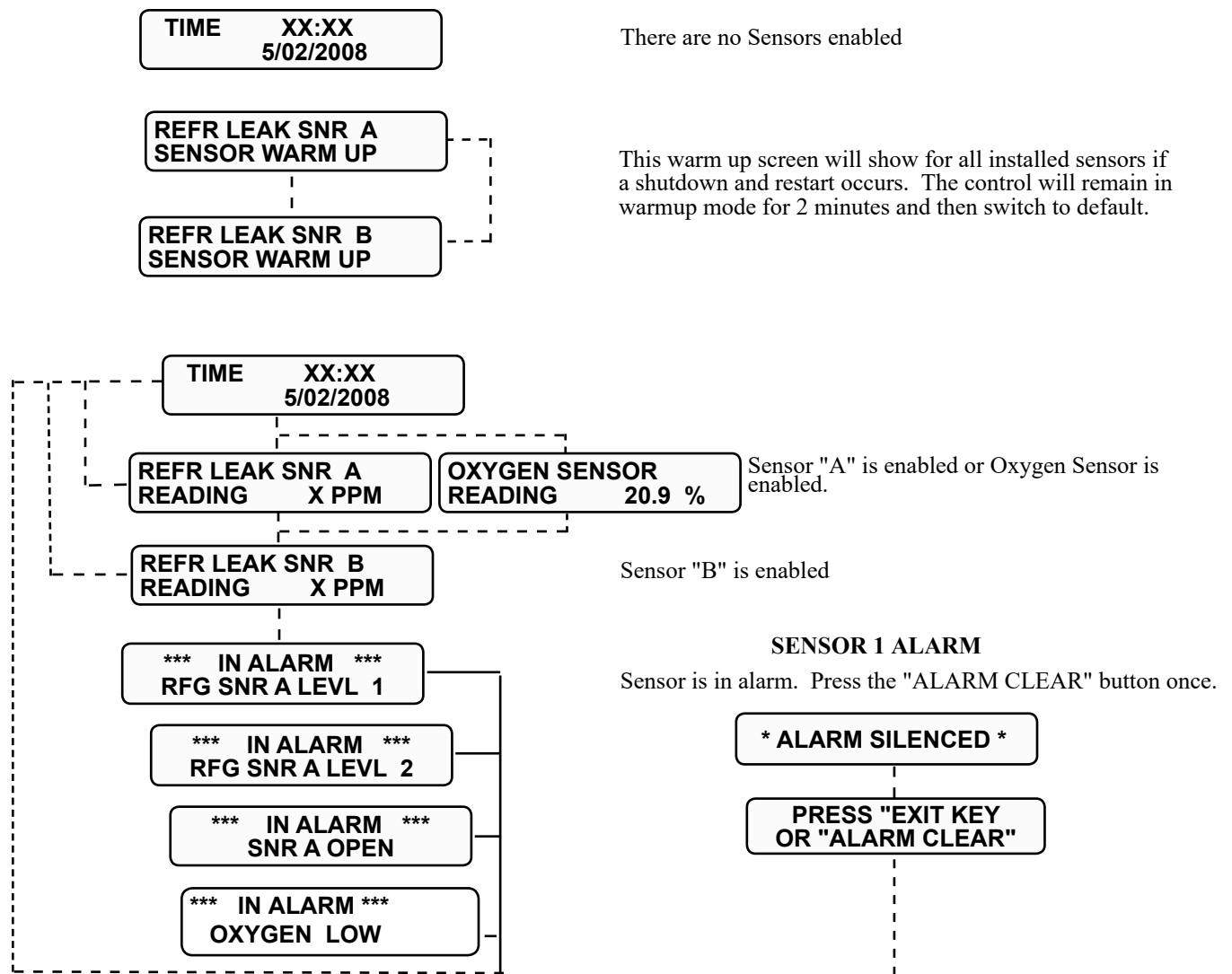

ALARM RESPONSE PROCEDURE

The Control will monitor each sensor according to the alarm settings. When the sensing level exceeds its alarm limit for the duration of its delay time, the Control will activate the appropriated alarm relays; Level 1 and/or level 2. The alarm will turn on the internal buzzer and external alarm light, and show the alarm messages. Pressing the "ALARM CLEAR" button on the front panel will turn off the internal buzzer and the K1 and K3 relays but keep the alarm light lit. The relays (K2 for level 1 and K4 for level 2 and configurable zone isolation alarm relays) can be silenced by pressing the "ALARM CLEAR" button a second time. The alarm light will also turn off. Do not press the "ALARM CLEAR" button if you do not want to clear the alarm so the Control will remain in this alarm state until manually cleared or automatically cleared. Once the "ALARM CLEAR" button has been pressed twice the Control will start new monitoring cycle. If the alarm conditions are not rectified it will go into alarm again after the alarm delay time. The alarm log can be seen in the alarm menu.

ACCESS MENU



PLACE CONTROL INTO THE "VIEW ONLY MODE", "IN CHANGE MODE" or "ALL ACCESS MODE". **VIEW ONLY MODE** allows user accessing Menus and Sub-menus, no control parameters can be changed. **CHANGE MODE** allows control parameters to be changed except parameters in the System Config Menu. **ALL ACCESS MODE** allows changes in all menus including System Config Menu. Control will remain in this selected mode for two hours, then it will automatically lock itself to **VIEW ONLY MODE**. If data access is blocked, the message "DENY" will be shown for not in the ALL ACCESS MODE or the message "LOCK" will be shown for not in the CHANGE MODE.

At DEFAULT SCREEN, press **UP/DOWN** arrow buttons until the "<ACCESS MENU>" screen appears.



Press **SELECT** button to enter the "<ACCESS MENU>". The control shows the mode it is in. When the CONTROL is first powered up or has not be accessed for sometimes it will be in the "VIEW ONLY MODE".



Press **SELECT** button to change the control to "IN CHANGE MODE".

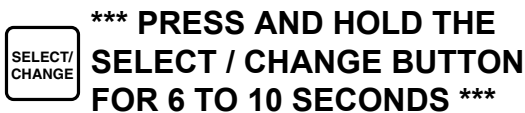

Press and hold the **SELECT/CHANGE** button for 6 ~10 seconds until the screen flashes over to "ALL ACCESS MODE".



Press **EXIT** button to exit this menu and return to DEFAULT SCREEN



STATUS MENU

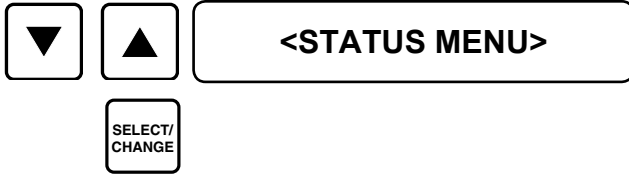

<STATUS MENU>

**<STS> 16:30
05/02/08**

**<STS> OXYGEN SNR
READING: 20.9 %**

**<ST> OXYGEN LEVEL
LOW ALARM: 17.0 %**

**<STS> LEAK SNR A
READING: 0 PPM**

**<ST> SNR A LEVEL 1
ALARM: 150 PPM**

**<ST> SNR A LEVEL 1
ALM DELAY: 2M**

**<ST> SNR A LEVEL 2
ALARM: 250 PPM**

**<ST> SNR A LEVEL 2
ALM DELAY: 2M**

REPEAT FOR SENSOR B

**<STS> SNR A SETBK
LVL1 ALM: 150 PPM**

**<STS> SNR A SETBK
LVL2 ALM: 250 PPM**

REPEAT FOR SENSOR B

This menu allows the user to view but not change the various controller parameters. Screen entries in "<STATUS MENU>" will only be shown if their respective control options are installed in the "<SYSTEM CONFIG MENU>"

At DEFAULT SCREEN, press **UP/DOWN** button to scroll to the "<STATUS MENU>". Press the **SELECT** button to enter this menu. "<STATUS MENU>" is shown on the first line of the display. The control status is shown on the second line of the display. These control status are:

The first screen shows the real time clock.

Oxygen Sensor Current reading if installed at the sensor A input.

Oxygen Sensor Alarm Setpoint.

Sensor A current reading if a refrigerant sensor was installed in the sensor A input..

Sensor A level 1 alarm setpoint

Sensor A level 1 alarm delay in minutes

Sensor A level 2 alarm setpoint

Sensor A level 2 alarm delay in minutes

Sensor 1 level 1 setback setpoint

Sensor 1 level 2 setback setpoint

Continued on next page

STATUS MENU



**<STS> SYSTEM ALM
RLY:NORMAL-OPEN**

This is the active state of the alarm relays.



**<ST>ZONE ALM RLY
ACTIVE BY LVL 1&2**

The optional zone alarm relays can be set for level 1&2 or just for level 2



**<ST>ZONE ALM RLY
:SILENCEABLE**

The zone alarms can be made silenceable or unsilenceable



**S>ALM AUTO CLEAR
AFTER NORMAL:YES**

The alarms can automatically clear or stay on and be manually cleared



**<STS> SYSTEM
VERSION 1.5**

Software version number



EXIT

Exit this MENU and return to DEFAULT SCREEN or down arrow to wrap around to the beginning of the STATUS menu.

ALARM LOG MENU



This menu also shows the most recent 10 alarm logs.

At DEFAULT SCREEN, press UP/DOWN arrow button to scroll to the "<ALARM MENU>". Press the **SELECT** button to enter this menu.

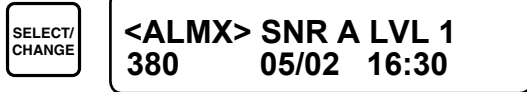

Each successive screen will show the last 10 alarms in reverse order. ie Last one first and the times the alarm was cleared. ALMX refers to Alarm number X (X = 1 through 10)



Down Arrow to the next 10 logs



Exit menu and return to the DEFAULT SCREEN

ALARM MESSAGE	DESCRIPTION
---------------	-------------

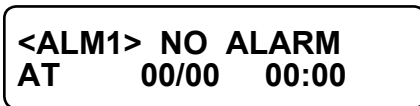

There is no alarm condition for this entry in the alarm log. All entries show no alarm if Alarm Log has been cleared in SYSTEM CONFIG MENU.

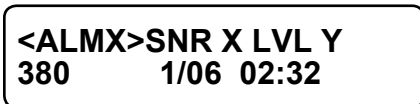

Sensor X was in alarm at Alarm level Y and reading XXX ppm on this date and time.

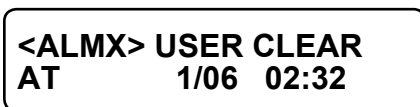

The previous alarm was cleared by the user on this date and time.



The previous alarm auto cleared by the control on this date and time.

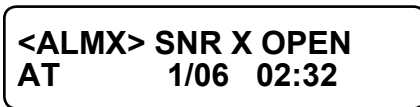

Sensor X was opened, no sensor return current path was detected on this date and time. Problem can either be a wiring problem, an incorrect style of sensor

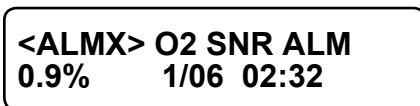

Sensor A was an Oxygen Depletion Sensor and was in an alarm condition on this date and time. This alarm will also activate if a refrigerant sensor is attached when the oxygen sensor is selected from the configure menu.





SETPOINT MENU



<SETPOINT MENU>

These Sub-menus are to be followed if the setpoints and alarm delays for one or all of the control system are to be changed. Prior to changing the control setpoints, ensure that the control system is in the "IN CHANGE MODE" or "ALL ACCESS MODE". At DEFAULT SCREEN, press UP/DOWN arrow button to scroll to the "<SETPOINT MENU>". Press the SELECT button to enter this menu. Screen entries will only be shown if their respective control options are installed in the SYSTEM CONFIG MENU.

To make any changes: Press SELECT button. The displayed value should begin to blink. Press UP/DOWN arrow buttons to change the value. Press SELECT button to accept the value. Press DOWN button to next entry

<SET> OXYGEN SNR ALARM 1, % 15.0



This Entry will be shown if sensor A is configured as Oxygen Sensor in SYSTEM CONFIG MENU.
OXYGEN SENSOR SETPOINT (15.0-25.0)



<SET> OXYGEN LOW ALM DLY,MIN: 1



OXYGEN SENSOR ALARM DELAY (1-10 MINUTES)



<ST>SNR A LEVEL1 ALARM,PPM: 150



This entry will be shown if sensor A is selected as a refrigerant sensor in the configuration menu

SENSOR A LEVEL 1 ALARM SETPOINT (20-999)



<ST>SNR A L1 ALM DELAY,MIN: 1



SENSOR A LEVEL 1 ALARM DELAY (1-120 MINUTES)



<ST>SNR A LEVEL2 ALARM,PPM: 250



SENSOR A LEVEL 2 ALARM SETPOINT (20-999)



<ST>SNR A L2 ALM DELAY,MIN: 1



SENSOR A LEVEL 2 ALARM DELAY (1-120 MINUTES)

REPEAT FOR SENSOR B IF APPLICABLE

Continued on next page

SETPOINT MENU

(THE SETBACK ENTRIES WILL NOT BE SHOWN IF SENSOR SETBACK OPTION WAS NOT INSTALLED.)

When the Control is in SETBACK MODE, the Setback Setpoint and Delay is used as the alarming criteria. The Setback Setpoint and Delay are usually set to a higher value. This prevents fault alarming in some applications. One example is CMOS sensor reading goes higher when propane floor buffer machine is in use. (See Page 45 for more on Setpoints)



**SENSOR 1 LEVEL 1 SETBACK ALARM SETPOINT
(20-999)**



**SENSOR 1 LEVEL 2 SETBACK ALARM SETPOINT
(20-999)**



REPEAT FOR SENSOR B IF APPLICABLE

Each sensor can have two levels of Alarming. The level 2 alarm of a particular sensor can be disabled. If enabled, the level 2 setpoint and delay can be modified. The two entries for the particular sensor will not be shown and level 2 alarm is disabled if level 1 alarm is not enabled.



Exit this MENU and return to DEFAULT SCREEN or down arrow to wrap around to the beginning of the menu.

CALIBRATION MENU



<CALIBRATION MENU>



**<CAL> CALIBRATE
O2 SENSR,%: 19.0**





**<CAL> CALIBRATE
CALIBRATE DONE**

**<CAL> OXYGEN SNR
ABS READ,% 21.0**

**<CAL> CALIBRATE
LEAK SENSOR A**

**<CAL> CALIBRATE
CONFIRM CAL.**

**<CAL> CALIBRATE
CALIBRATE DONE**

**<CAL> SNR A ABS
READ,PPM: 10**

**READING > 80 PPM
READING > 80 PPM**

REPEAT FOR SENSOR B



**<CAL> UNDO ALL
SNR CALIBRATION**

**<CAL> UNDO ALL
CONFIRM UNDO**

**<CAL> UNDO ALL
UNDO CAL DONE**



This page and the next contain a brief overview of the "<CALIBRATION MENU>" of the Sherlock Control System. The pages after these two contain specific instruction on calibrating the Sherlock Monitoring System and its sensors.

The CALIBRATION MENU contains three basic functions:

CALIBRATE OXYGEN SENSOR

These screens are only shown if Oxygen sensor was selected in the "CONFIGURATION" menu. Press **SELECT** button. The displayed setpoint value should begin to blink. Press **UP/DOWN** arrow buttons to change the value. Press **SELECT** button to accept this calibrated value. Press **DOWN** button to next entry.

OXYGEN SENSOR ABSOLUTE READING

This reading is the actual raw reading produced by the sensor before calibration. Its reading must be greater than zero This reading can be used to check the proper cable connection.

ZERO CALIBRATION

These instructions apply to the refrigerant sensor(s) activated in the "CONFIGURATION" menu. This function will allow the user to factor out the sensor's designed "zero" and any ambient effects on the sensor by resetting the currently displayed reading to zero. Any lost signal due to the long run cable wiring is also compensated. Follow this procedure for each sensor.

Each sensor will now produce a zero reading when zero ppm of gas is detected.

SENSOR ABSOLUTE READING

This reading is the actual raw reading produced by the sensor without the zero offset. Its reading must be greater than zero (10-80). This reading can be used to check the proper cable connection.

If the sensor is reading greater than 80, the sensor will not calibrate. Check for gas leak around the sensor. If no leak is found, do the calibration on the sensor itself then do the Control sensor calibration again.

UNDO (RESET) ZERO CALIBRATION

This function will clear the zero offset calibration for all sensors. The sensor reading will be the same as ABS(ABSOLUTE) reading. The reading will always be more than zero(10-25) Make sure to calibrate each sensor to have the sensor reading at zero level when no gas is detected.

Exit this menu and return to DEFAULT SCREEN.

SYSTEM CONFIG MENU



CONFIGURE THE CONTROL IN THE <SYSTEM CONFIG MENU>

At DEFAULT SCREEN, press **UP/DOWN** arrow buttons until the <SYSTEM CONFIG MENU> screen appears. Press **SELECT** button to enter the "SYSTEM CONFIG MENU". It is recommended that before the Sherlock Control Module is initially programmed, the memory should be cleared. If you do not want to clear the controller's memory, skip the CLEAR MEMORY section.

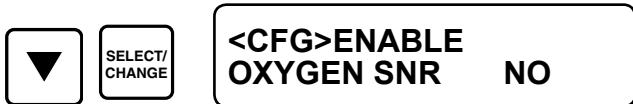

OXYGEN SENSOR SETUP

Sensor A has the option of being configured as a refrigerant gas sensor or as an oxygen depletion sensor. If you do not have the OXYGEN SENSOR, do not turn on this entry, else the sensor reading will be all wrong.



Press the **SELECT** button. The "NO" ("YES") will begin to blink indicating that the controller is in the Change mode. Press **UP/DOWN** arrow buttons to change to "YES" ("NO"), press **SELECT** button to save this entry.



SENSOR A SETUP

Each sensor will indicate its selected entry. To enable/disable a sensor, press **SELECT** button. The "NO" ("YES") will begin to blink. Press **DOWN** arrow. The blinking "NO" ("YES") will change to a blinking "YES" ("NO"). Press **SELECT** button to save this entry.

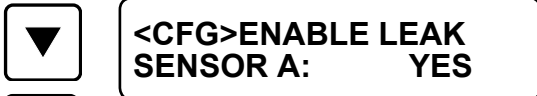

If Sensor A is not enabled, the Control will not display entries related to sensor A and will skip to next enabled entry.



Press **DOWN** arrow button to move to the next option.

Determine whether Sensor A shall have a Setback Option (See INTRODUCTION section). Set the type of setback option for Sensor A. The options are:



OFF No Setback Option

IN1 Setback controlled by Digital Input #1 & Schedule

IN2 Setback controlled by Digital Input #2 only



To set the setback option, press **SELECT** button. The "NO" will begin to blink. Press **DOWN** arrow button. The blinking "NO" will change to a blinking "IN1", Press **DOWN** arrow button again to a blinking "IN2". At proper setting, press **SELECT** button to save this entry. This is the end of sensor A setup.

REPEAT FOR SENSOR B

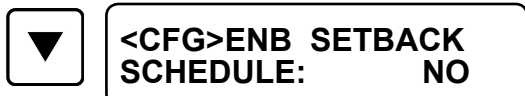

Press the **DOWN** arrow button to move to next entry. To

run the setback schedule by time, set this entry to ON. Press **SELECT** button, and "NO" ("YES") will begin to blink.

Press **DOWN** arrow button. The blinking "NO" ("YES") will change to a blinking "YES" ("NO"). Press **SELECT** button to save this entry



SYSTEM CONFIG MENU



**<CFG>SETBACK SCH
ON TIME 12:00**

Press the **DOWN** arrow button to move to next entry. To set the Setback begin time, press **SELECT** button. The time will begin to blink. Press the **UP/DOWN** arrow buttons to the desired time. Press **SELECT** button to save this entry



**<CFG>SETBACK SCH
OFF TIME 12:00**

Press the **DOWN** arrow button to move to next entry. To set the end time, press **SELECT** button. The time will begin to blink. Press **UP/DOWN** arrow buttons to the desired time. Press **SELECT** button to save this entry



**<CFG> ZONE ALARM
RELAY OPTION: NO**

Press the **DOWN** arrow button to move to next entry. Use this screen if you have the zone Isolation alarm relays factory installed. They would be relays 5 through 8 on the main input / output board.



**<CFG> ZONE ALARM
RELAY OPTION: YES**

To set this entry to ON. Press **SELECT** button, and "NO" ("YES") will begin to blink. Press **DOWN** arrow button. The blinking "NO" ("YES") will change to a blinking "YES" ("NO"). Press **SELECT** button to save this entry



**<CF>ZONE ALM RLY
ACTIVE BY: LVL 2**

Press the **DOWN** arrow button to move to the next option. Set the zone isolation alarm relay trigger level (The zone isolation alarm relays are optional and must be installed at the factory). Press **SELECT** button, "2" ("1&2") will begin to blink. Press **DOWN** arrow button. The blinking "2" ("1&2") will change to a blinking "1&2" ("2"). Press **SELECT** button to save this entry The zone isolation relays will activate on either level 1 &2 or level 2 alone.



**<CF>ZONE ALM RLY
ACTIVE BY: LVL 1&2**



**<CF>ZONE ALM RLY
ACTIVE BY: LVL 1&2**



**<CF>ZONE ALM RLY
SILENCEABLE: YES**

Press **DOWN** arrow button to move to the next entry. Set zone isolation alarm relays silenceable by the front panel silent button . The selection applies to all the zone isolation relays. Press **SELECT** button, and "NO" ("YES") will begin to blink. Press **DOWN** arrow button. The blinking "NO" ("YES") will change to a blinking "YES" ("NO"). Press **SELECT** button to save this entry



**<CF>ZONE ALM RLY
SILENCEABLE: NO**



**<CF>ZONE ALM RLY
SILENCEABLE: YES**



**<CF>SYS ALM RLY
ACTIVE MODE N.O.**

Press **DOWN** arrow button to move to the next option. Set the Active Mode for the level 1 relays K1/K2. The alarm relays can be set to "N.O." (Normally Open) or "N.C." (Normally Closed) modes. To change Active Mode, press **SELECT** button. The "YES" ("NO") will begin to blink. Press **DOWN** arrow button to change the blinking "YES" ("NO") to a blinking "NO" ("YES"). Press **SELECT** button to save this entry. The active mode can be verified by looking at the relays. In N.O. Mode, the LED is off. In N.C. Mode, the LED is on.



**<CF>SYS ALM RLY
ACTIVE MODE N.O.**



**<CF>SYS ALM RLY
ACTIVE MODE N.C.**

SYSTEM CONFIG MENU

▼	SELECT/ CHANGE	<C>ALRM AUTO CLR AFTER NORMAL: YES
	▼	<C>ALRM AUTO CLR AFTER NORMAL: NO
	SELECT/ CHANGE	<C>ALRM AUTO CLR AFTER NORMAL: YES
▼	SELECT/ CHANGE	<CFG>REMOTE COMM STATION NO: 1
	▼	<CFG>REMOTE COMM STATION NO: 199
	SELECT/ CHANGE	<CFG>REMOTE COMM STATION NO: 199
▼	SELECT/ CHANGE	<CFG>REMOTE COMM BAURATE,K: 9.60
	▼	<CFG>REMOTE COMM BAURATE,K: 9.60
	SELECT/ CHANGE	<CFG>REMOTE COMM BAURATE,K: 9.60
▼	SELECT/ CHANGE	<CFG> CLEAR ALL CONFIGURES: NO
	▼	<CFG> CLEAR ALL CONFIGURES: YES
	SELECT/ CHANGE	<CFG> CLEAR ALL CONFIGURES: NO
▼	SELECT/ CHANGE	<CFG> CLEAR ALL ALARM LOGS: NO
	▼	<CFG> CLEAR ALL ALARM LOGS: YES
	SELECT/ CHANGE	<CFG> CLEAR ALL ALARM LOGS: NO
EXIT		

Press **DOWN** arrow button to move to the next option. Set the Latch Action for all relays. The alarm relays can be set to "NO" (Alarms stay active until reset by a technician) or the "YES" (Alarm will autoclear when alarm conditions clear) modes. To change latch method, press **SELECT** button. The "YES" ("NO") will begin to blink. Press **DOWN** arrow button to change the blinking "YES" ("NO") to a blinking "NO" ("YES"). Press **SELECT** button to save this entry.

Press the **DOWN** arrow button to move to the next option. Communications Station Number **THIS OPTION IS FOR REMOTE COMMUNICATIONS AND IS NOT AVAILABLE ON ALL UNITS AND REQUIRES GENCOM SOFTWARE. IF YOU DO NOT HAVE THIS FEATURE IGNORE THIS SCREEN.** To set the baud rate, press the **SELECT** button. The "1" will begin to blink. You can enter from 1 to 199. Press the **UP/DOWN** arrow button to change to the desired value. Press the **SELECT** button to save this entry.

Press the **DOWN** arrow button to move to the next option. Communications Baud Rate **THIS OPTION IS FOR REMOTE COMMUNICATIONS AND IS NOT AVAILABLE ON ALL UNITS AND REQUIRES GENCOM SOFTWARE. IF YOU DO NOT HAVE THIS FEATURE IGNORE THIS SCREEN.** To set the baud rate, press the **SELECT** button. The "9.6" will begin to blink. The settings are 9.60, 14.4, 19.2, and 38.4. Press the **DOWN** arrow button to change to the desired value. Press the **SELECT** button to save this entry.

Press the **DOWN** arrow button to move to the next option. Press the **SELECT** button to activate the "CLEAR CONFIGURES" routine, "YES" starts to blink. Press **DOWN** arrow button. The Control will ask to confirm the configure memory clearing. If you do not want to clear the configures, press **DOWN** arrow button. If you want to continue, press **SELECT** button and then **DOWN** arrow button to start clearing EEPROM, and RAM. After memory clearing and testing, the "MEMORY OK" message will be shown.

CLEAR ALARM LOG

The alarm log has 10 entries that keeps the most recent alarms. These entries can be cleared using the following procedure, Press **SELECT** button to activate the clear alarm log function. The message "YES" will start to flash, Press **UP/DOWN** arrow button. The controller will ask you to confirm one more time. If you do not want to clear the memory, press **UP/DOWN** arrow button else press **SELECT** button to change the blinking "NO" to a blinking "YES". Press **UP/DOWN** button to begin the alarm log clearing routine.

Exit this menu and return to DEFAULT SCREEN.

SET TIME MENU



The year, month, day and time can be viewed and changed here. At DEFAULT SCREEN, press UP/DOWN arrow buttons until the "<CLOCK MENU>" screen appears. Press SELECT button to "<CLOCK MENU>".

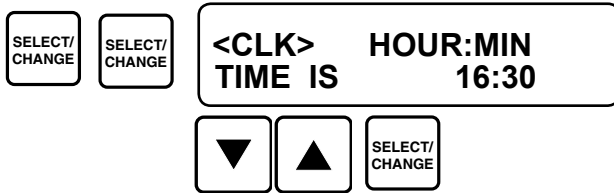

SET THE TIME

Press SELECT button. The time should start to blink. Press UP/DOWN arrow buttons to change to the desired time. The UP/DOWN arrow can be held down. Press SELECT button to save it. The time is displayed as to 24 Hour "Military time".



SET THE MONTH/DAY

Press SELECT button. The month/day should start to blink. Press UP/DOWN arrow buttons to change to the desired value. Press SELECT button to save it.



SET THE YEAR

Press SELECT button. The Year should start to blink. Press UP/DOWN arrow buttons to change the year to the desired value. Press SELECT button to save it.





SET FOR DAYLIGHT SAVINGS

Press SELECT button. The NO should start to blink. Press UP/DOWN arrow buttons to change to YES or NO. Press SELECT button to save it.





Exit this menu and return to DEFAULT SCREEN

TEST MENU



<TEST MENU>





<T> TOGGLE RELAY
LVL1 ALARM:



<T> TOGGLE RELAY
LVL1 ALARM: ON



<T> TOGGLE RELAY
LVL1 ALARM: OFF



REPEAT FOR UP TO 8 RELAYS



<TESTING>TOGGLE
HORN/STROBE: OFF



<TESTING>TOGGLE
AUX1 STROBE : ON







<TST>TEST 4-20MA
WHEN SNR A= XX



<TST>TEST 4-20MA
WHEN SNR A= XX









<TST> RE-START
THIS CONTROL : NO



<TST> RE-START
THIS CONTROL : YES

<TST> RE-START
CONFIRM: NO



<TST> RE-START
CONFIRM: YES



<TST> RE-START
IN 2 SECONDS ...



This menu is provided to facilitate wiring checks for each output. When entering into this menu, the relays retain their operating states. The relays can be turned ON (Energized) or OFF (De-Energized) by the user. The N.O. or N.C. settings on alarm relays have no effect on the test. When exiting from this menu, the preset states for all settings prior to entering this menu will be resumed. Refer to the input/output diagram on page 20.

TEST RELAY K1

This feature is used to test each dry contact relay. One at a time. Press **SELECT** button to toggle between "ON" and "OFF". Down arrow to move to the next screen.

Follow the same procedure for **LVL1 SIL-ALM**, **LVL2 ALARM**, **LVL2 SIL-ALM**, and also optional zone isolation relays **ZONE A ALM**, **ZONE A SIL**, and **ZONE B ALM**, **ZONE B SIL**, if installed.

TEST HORN/STROBE AND STROBE LIGHT INPUT

HORN/STROBE and **STROBE LIGHT** can be used to direct connect a 12 VDC Strobe or Horn/Strobe so as not to use any relays. This screen can be used to test the wiring for each. Press **SELECT** button to toggle between "ON" and "OFF" to activate the alarm device connected to **HORN/STROBE**. Do the same for **STROBE LIGHT**.

TEST 4-20 MILLIAMP OUTPUT

This feature tests the optional 4-20mA This output located on the input/output board. Press the **SELECT** button. The reading for the **Sensor A** PPM level will begin to blink. Press the **UP** or **DOWN** arrow. The blinking number will go up or down between 0 ppm and 1500 ppm. Press the **SELECT** button to save this entry and to read the current output. Do the same for **Sensor B** if applicable.

RESTART

This function is only necessary if for some reason the control will not operate properly. Doing restart will not clear any previous settings already input. This is equivalent to powering down and powering back up.

Press the **SELECT** button. The "NO" ("YES") will begin to blink indicating that the controller is in the Change mode. Press **UP/DOWN** arrow buttons to change to "YES" ("NO"), press **SELECT** button to save this entry.

The control will then ask for a confirmation. Press the **SELECT** button. The "NO" ("YES") will begin to blink indicating that the controller is in the Change mode. Press **UP/DOWN** arrow buttons to change to "YES" ("NO"), press **SELECT** button to save this entry.

RE-START will automatically begin.

Exit this menu and return to **DEFAULT SCREEN**. All relay outputs will return to their operating states prior to entering test menu.

CALIBRATION

Prior to shipment, all sensors manufactured by Genesis International, Inc. are factory calibrated. The calibration method will set the base level (or Zero Level) and the gain (or Slope). As the sensor gets older or the ambient conditions change drastically, the Zero Level may drift upward or downward. The Gain (Slope) will not normally change.

Periodic adjustment (no more than every six months) of the Zero Level is necessary to ensure that the Sherlock Sensor is reading accurately. This function can be performed in a number of different ways. The first and most expeditious method is to "offset" the Zero Level by programming an offset or by conducting a Zero Calibration within the Sherlock control systems. If calibration is beyond the offset limit (> 80) then the second

method is to adjust the zero offset on the sensor itself. More complex method involving exposing the sensor to pre-measured gas concentrations, mimicking one of the factory calibration procedures. A Sherlock Refrigerant Sensor Calibration and Test Kit is required for this method.

For CMOS sensor, turning the potentiometers CCW will lower the readings, CW will raise the readings. After turning a potentiometer, you must wait at least 30 seconds for the readings to stabilize before making any other adjustments or continuing to the next step.

For IR sensor, zeroing function is accomplished by pushing a push button on the sensor for six seconds. Refer to the OPERATIONS section of this manual.

Zero Calibration - Sherlock 102 & 202 Control, CMOS and IR Sensors

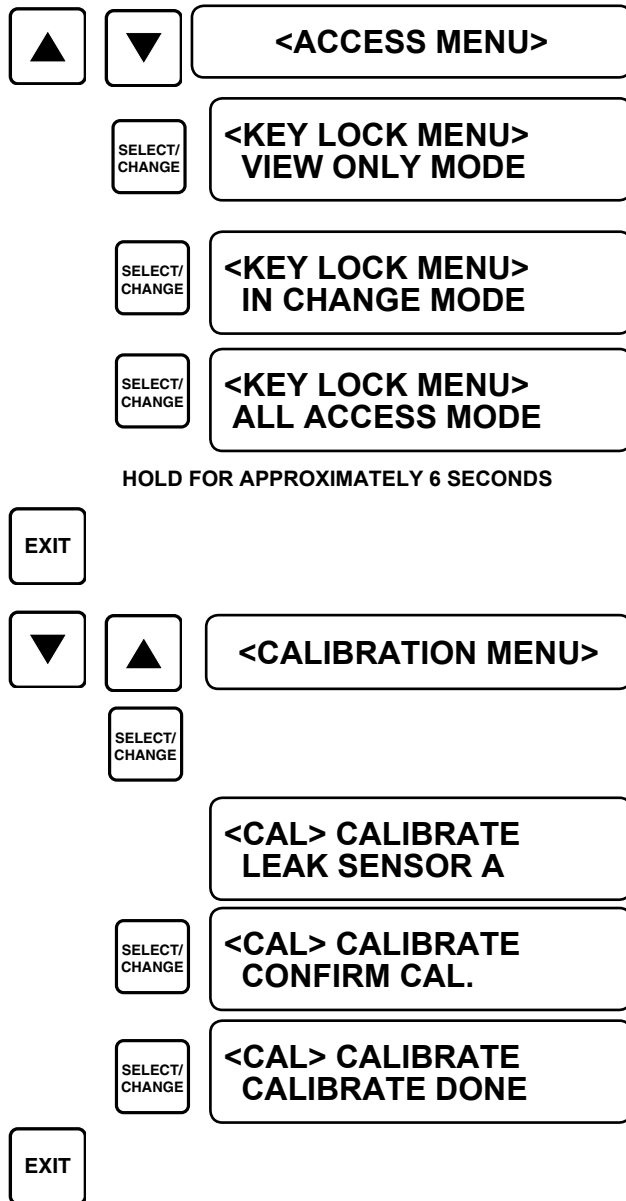

Prior to continuing, ensure that the sensors are properly connected to the SHERLOCK 2-Series Monitor and that the sensor has been energized for over 7 hours.

1. Place the Sherlock into the Calibrate Sensor Mode

At DEFAULT SCREEN, using UP/DOWN buttons to scroll to "<ACCESS MENU>". Press **SELECT** button. If the control display shows "IN CHANGE MODE" or "ALL ACCESS" mode, then press **EXIT** Button. If not, press **SELECT** button, changing the Control to "IN CHANGE MODE". Press **EXIT** button.

Using **UP/DOWN** arrow buttons place the Sherlock into the "<CALIBRATE MENU>".

Press **SELECT** button.

Using **UP/DOWN** arrow buttons to scroll to function "CAL SENSOR X" where "X" is the sensor being calibrated.

Press **SELECT** button. The display should state "SEL Button TO CONFIRM".

Press **SELECT** button. The display should show "CALIBRATION DONE".

NOTE: If the sensor is reading greater than 80, the sensor will not calibrate. Check for gas leak around the sensor. If no leak is found, do the calibration on the sensor itself then do the Control sensor calibration again.

OR

Do the sensor calibration and follow the instructions for the Measured Gas Calibration.

Please Note: The Zero Calibration procedure is usually all that is needed for initial startup of the Electro-Chemical NH3 sensor.

CALIBRATION KIT.

The Calibration Kit contains the following items:

- Carrying Case
- Flow Regulating Valve
- Calibration Chamber
- 2.5 ft Vinyl Tubing
- Calibration Gas - Zero Level
- Calibration Gas - Span Gas.

Flow Regulating Valve. The Flow Regulating Valve permits the sensor chamber or the IR Sensor chamber to be filled at a constant rate.

Calibration Chamber. The Calibration Chamber allows the CMOS and Oxygen sensors to be sealed into a controlled environment.

2.5 ft Vinyl Tubing. To connect the valve to either the Calibration Chamber or to the IR Sensor Chamber.

Calibration Gas - Zero Level. 79.1% Nitrogen/20.9% Oxygen, 34 L gas, compressed.

Calibration Gas - Span Gas.

Refrigerant Sensor-Measured concentration of refrigerant gas and N₂/O₂.

Oxygen Sensor - 23% Nitrogen/17% Oxygen, 34 L gas, compressed.

Measured Gas Calibration IR Sensor (Optional) Equipment Required.

One Sherlock Refrigerant Sensor Calibration and Test Kit :

The measured gas calibration procedure may be used as a double check of sensor accuracy and only needs to be done if there are questions of whether or not the sensor is working. It is not necessary to use measured gas to calibrate the infrared sensor. If you choose to, you can perform the calibration procedure outlined in the calibration test kit. Since the infrared sensor does not fit in the calibration chamber, a plastic bag or other airtight container must be used. The reading on the monitor will be off due to dilution of the gas with the air still in the container.

Another procedure involves changing the air currents drastically inside the sensing chamber, so please use the procedure listed below only as a test. Since the gas is forced into the sensor the reading will not be as accurate as a normal reading. At the factory we allow for normal airflow that would occur in a real leak when we calibrate the sensor and set the zero level. So there will be an artificial reading between the zero gas and measured gas because of the unusual air currents involved.

1) Place the Plastic tubing that comes with the calibration kit over the inlet valve on the top right of the sensing tube and connect the other end to the calibration gas canister regulator.

2) Run the 20.9% O₂ gas into the sensor for about 5 minutes and wait for the reading to settle. Press the push button on the sensor right above the dipswitch for 10 seconds. This will be the artificial zero level.

3) Next run the measured refrigerant gas into the sensor for about 5 minutes. The difference between the artificial measured gas reading and the artificial zero level reading should be close to the measured gas concentration however the way the gas is pumped in will create errors in the accuracy of the reading.



SHERLOCK CALIBRATION/TEST KIT

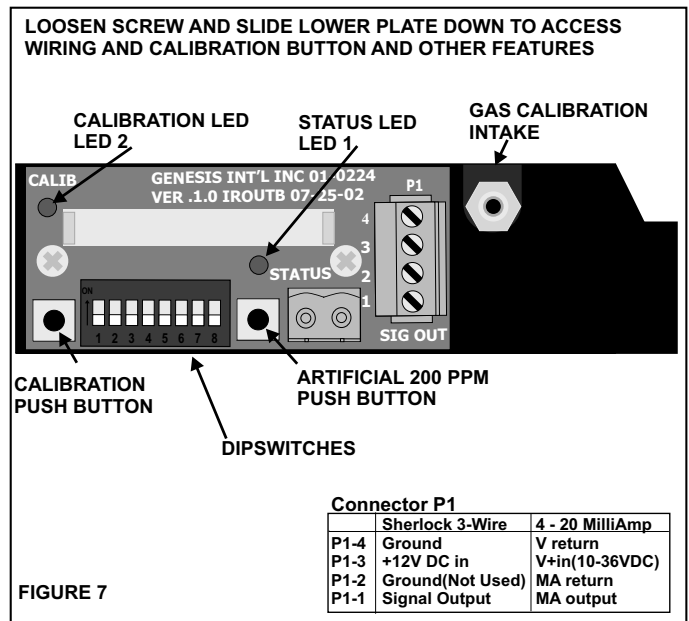

INFRARED SENSOR INPUT WIRING AND CALIBRATION BOARD

CALIBRATION

4) Once the measured gas testing is complete and no gas is present and the sensor is mounted in normal conditions, do the push button calibration once again to remove any artificial readings that were introduced during measured gas calibration.

To aid in performing the maintenance schedule, remember to write down the sensor start up date on the front of the sensor. If it is not written down and a problem due to calibration occurs, this will void the warranty.

Measured Gas Calibration - Sherlock CMOS Sensor

To accurately calibrate the Sherlock CMOS Sensor, the Refrigerant Gas Sensor Calibration Kit for the particular sensor must be used. (See 44-0166 Refrigerant Sensor Calibration for more.)

Note: This procedure can be used on the Standard CMOS Ventline Sensor (See manual 44-0163 Ventline Sensor manual for more) and High Pressure CMOS Ventline Sensor (See manual 44-0321 High Pressure Ventline Sensor manual for more)

Kit Setup Instructions

1. Insert the tube into the fitting at the end of the chamber, tighten the fitting until the tube is snug.
2. Remove the sensor from the wall or mounting point. Take the front face cover off of the sensor.
3. Mounting the Sensor
 - a. Place the chamber on its side so that the tube comes out from the left or right side.
 - b. Mount the sensor module in the chamber using the supplied mounting screw, making sure that the cable fits into the notch at one end of the chamber.
 - c. Seal the chamber.
4. Take the free end of the tube and mount it onto the barbed end of the flow regulating valve.

Calibration Procedures.

1. Filling the Chamber
 - a. Mount the valve onto the 20.9% Oxygen tank. Open the valve for 1 minute. Close the valve.
 - b. Wait 2 minutes.
 - c. Open the valve again for 1 minute and close.
 - d. Wait 2 minutes.
2. Place the controller into the Sensor Absolute Screen.
 - a. Press EXIT.
 - b. Press the DOWN arrow until the "CALIBRATE" Menu is displayed. Press SELECT.
 - c. Press the DOWN arrow until you reach the "ABS X: YYY" screen where X is the sensor being calibrated.
3. With the supplied Potentiometer Screwdriver, adjust the potentiometer until the displayed reading is 40. If the reading is too high or too low and the potentiometer has no effect on the reading, open the chamber and change the position of the set pin jumper one position lower if the reading is too high, or one position higher if the reading is too low.

It is recommended that infrared sensors are zero calibrated every 6 months to insure accuracy. Most of the time push button calibration and control calibration is all that is needed to re zero the sensor and keep it from false alarming. Measured gas calibration should only be necessary for testing accuracy and if the sensor fails to pick up a leak and is suspected of being damaged or faulty.

4. Conduct the Zero Calibration procedure for this particular sensor. (See manual 44-0283 CMOS Refrigerant Gas Sensor for more)

5) You can now test the sensor using the measured refrigerant gas tank. Follow the Calibration procedure step 1 "Filling The Chamber" using the span gas and record the value. If you achieve the desired reading on the first try, there is no need to open the valve a second time.

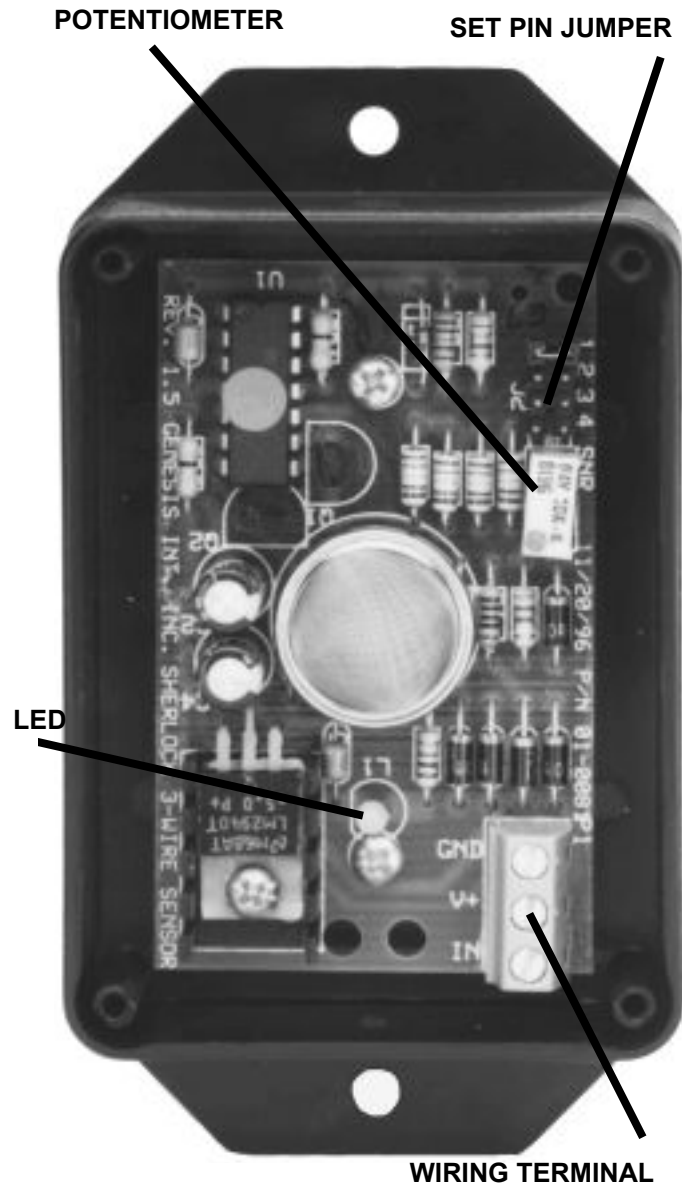

Calibration - Sherlock Oxygen Sensor

See manual 44-0165 Oxygen Sensor Calibration for more

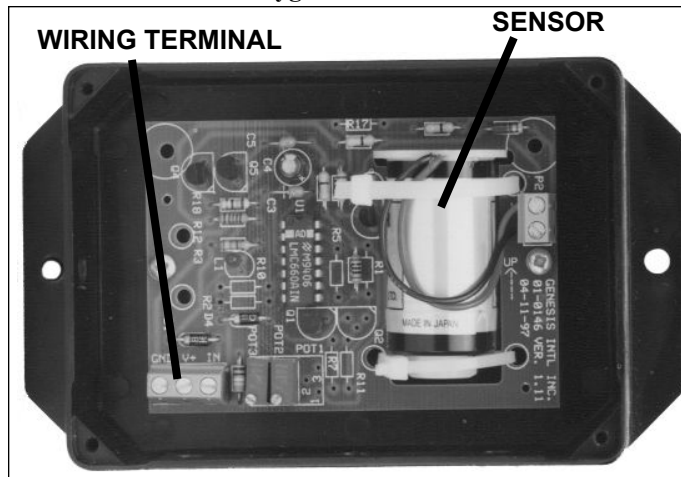

PROPER MOUNTING OF THE ELECTROCHEMICAL SENSOR

ZERO CALIBRATION INSTRUCTIONS

Prior to continuing, ensure that the sensors are properly connected to the SHERLOCK Monitor and that the sensor has been energized for over 3 hours.

NOTE: If the sensor is reading too far from 20.9%, the sensor will not calibrate. The display will read "CALIBRATION ERROR". Check the oxygen levels around the sensor. If everything is okay, it may be necessary to do the calibration on the sensor itself. This process is also called Sensor Zero Offset and is discussed on this page. Once this is done then do the Control sensor calibration again.

To accurately calibrate the Sherlock O2 Depletion Sensor, the O2 Sensor Calibration Kit must be used.

Kit Setup Instructions

1. Insert the tube into the fitting at the end of the chamber, tighten the fitting until the tube is snug.
2. Remove the sensor from the wall or mounting point. Take the front face cover off of the sensor.
3. Mounting the Sensor
 - a. Place the chamber on its side so that the tube comes out from the left or right side.
 - b. Mount the sensor module in the chamber using the supplied mounting screw, making sure that the cable fits into the notch at one end of the chamber.
 - c. Seal the chamber.

NOTE: Sensor module must be mounted so that the sensor (spool-like object) is sitting straight up and down with the wires at the top.

4. Take the free end of the tube and mount it onto the barbed end of the flow regulating valve.

Calibration Procedures.

- 1) Filling the Chamber
 - a. Mount the valve onto the 20.9% Oxygen tank. Open the valve for 2 minutes.

- b. Wait 5 minutes.
- c. Open the valve again for 2 minutes.
- d. Wait 5 minutes.

2) Follow these programming procedures.:

Ensure that the control access in "IN CHANGE MODE" or "ALL ACCESS" mode.

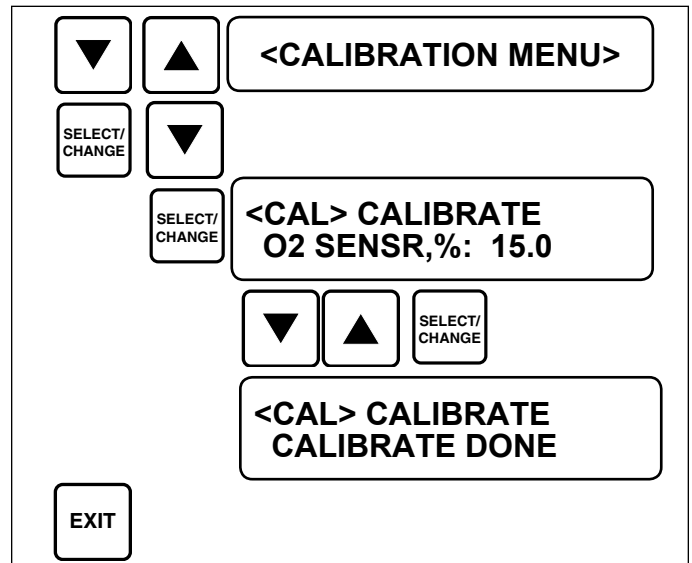

Using UP/DOWN arrow buttons, place the Sherlock into the "CALIBRATION MENU". Press SELECT button.

Using UP/DOWN arrow buttons, locate the function "CALIBRATE SNR O2"

Press SELECT button. The value should start blinking.

Use UP/DOWN arrow buttons to change the values to 20.9%. Press SELECT button to accept the value.

The screen will show "CALIBRATION DONE" message.

Exit this menu and return to DEFAULT SCREEN

3) You can now test the sensor using the 17% Oxygen / 83% Nitrogen tank. Follow the Calibration procedure step 1 "Filling The Chamber" using the span gas and record the value.

Offset Calibration

If the Oxygen sensor reading is too low to calibrate to 20.9%:

- 1) Make sure the air in the room is not contaminated and the oxygen content is not at a dangerous level.
- 2) Has the sensor been warmed up for at least 3 hours?
- 3) Is the **SHERLOCK** control set to monitor an oxygen sensor?
- 4) Is the sensor receiving 12 VDC between V+ and Ground from the Sherlock.

If so,

- 1) Undo all calibration at the control and then open the sensor cover and look for the two potentiometers located next to the wiring terminal. They are labeled POT 2 and POT 3.
- 2) Turn POT 3 Clockwise to raise the reading until it reads approximately 20.
- 3) If POT 3 has no effect, then try POT 2.
- 4) If still no change the sensor is bad.

TROUBLE SHOOTING

SHERLOCK CMOS (SOLID STATE) REFRIGERANT GAS SENSOR

Please See CMOS Sensor manual 44-0283 for more information.

LED L1 - LED L1 will indicate whether the sensor is powered up and if the internal circuitry is operating properly. The LED is color coded. Green is for CFC, HCFC and HFC gases. Amber is for Ammonia (NH3).

LED Status

Solution

Off	Sensor is not powered up. Check power. Ensure that the sensor is being powered by 12V AC or DC. Call Genesis Customer Service if LED is still off.
ON Steady	Sensor is powered up. Sensor is operating properly.

Sensor Reading

Solution

Sensor reading shows the presence of gas	Check space with a hand held leak detector for a leak. If no leak, follow the zero calibration instructions. Next move the sensor to another location or swap positions with another sensor. If readings "move" with the sensor, call Genesis Service.
Sensor output indicates a full scale reading	If readings "stay" at original location, check for wiring problems or the presence of gas. Double check signal wire connection.
Sensor output indicates an "open circuit"	Check for wiring problems, jumpers not properly set.
Sensor output indicates a "short circuit"	Check wiring. Sensor Element may have malfunctioned. Call Genesis Customer Service Check for continuity wiring problems.

MAINTENANCE SCHEDULE

The Solid State CMOS sensor should last 3 to 5 years under normal conditions. Extreme temperatures, or exposure to refrigerants or other gases will severely decrease the sensor's life expectancy. To insure a reading as accurate as possible, these sensors need to be zero calibrated every 6 months. It is strongly recommended to follow the zero calibration instructions on page 6 to rezero the sensors. Measured gas calibration testing should only be necessary for double checking accuracy and testing to see if the sensor is working properly.

Genesis customer service. If it still reads full scale double check for proper wiring. How old is the sensor? Check start up date on the sensor cover.

TROUBLE SHOOTING

SHERLOCK INFRARED GAS SPECIFIC REFRIGERANT GAS SENSOR

Please See Infrared Sensor manual 44-0295 for more information.

LED L1 - LED L1 will indicate if the sensor microprocessor is operating and if the sensor is in test mode using dip switch 5 or pushbutton 1. When the microprocessor goes through start-up, it will turn on L1 and keep it on unless the microprocessor detects a failure of any of the sensor components .

LED L2 - LED L2 is used for calibration of the sensor and is normally off. When the Push Button Calibration is done, L2 will turn on in about 8 seconds then turn off when Push button is released.

LED Status	Condition	Solution
L1 On Steady	Sensor is operating properly.	Sensor is working within acceptable limits
L1 Off	Sensor is not powered up.	Check power connector. Ensure that the sensor is being powered by 12 Volts DC. Ensure that wire connections are secure and are correct polarity. Microprocessor detects an error in the sensor hardware or Microprocessor Failure. Call Genesis Customer Service
L1 on Flashing	Switch 5 is on and there is a 200 ppm reading on the sensor Microprocessor detects error in the sensor signal.	Switch Dip Switch SW5 to other position. If switching SW5 does not work, call Genesis Customer Service
L2 Off	Sensor is operating properly.	Sensor is working within acceptable limits
L2 On Flashing	Microprocessor Failure	Call Genesis Customer Service. Check start up date on the sensor cover
L2 On Steady	Sensor is on factory calibration setting	Turn Dip Switch 6 off and wait at least 1 minute for L2 to turn off and do Push Button calibration again.
Sensor Reading	Sensor reading shows the presence of gas Sensor output indicates a full scale reading	Make sure Dip Switches are set to off position. If on, Switch 5 will show approximately 200 ppm, Switch 7 will read 250 ppm plus the original sensor reading. Check area around sensor with a hand held leak detector for refrigerant. If no leak, was the calibration procedure followed. Attempt calibration procedure. Move sensor to another location or, if possible, swap positions with another sensor. If readings "move" with the sensor, call Genesis Service, if readings "stay" at original location, check for wiring problems or the presence of gas. Check for wiring problems. Turn Dip Switch 5 to on. If the control reads about 200 there could be a sensor problem and contact Genesis customer service. If it still reads full scale double check for proper wiring. How old is the sensor? Check start up date on the sensor cover.

MAINTENANCE SCHEDULE

It is recommended that infrared sensors are zero calibrated every 6 months to insure accuracy. To aid in performing the maintenance schedule, remember to write down the sensor start up date on the front of the sensor. If it is not written down and a problem due to calibration occurs, this could void the warranty. These sensors can last an average of 5 to 7 years if the maintenance schedule is followed.

Most of the time push button calibration and control calibration is all that is needed to re zero the sensor and keep it from false alarming. See step 4 of quick start in the infrared sensor manual for more. Measured gas calibration should only be necessary for testing accuracy and if the sensor fails to pick up a leak and is suspected of being damaged or faulty. If a sensor is placed in a multi-use room where different temperatures will be used depending upon the product stored, it may be necessary to re-zero the sensor when the proper product temperature has been achieved.

TROUBLE SHOOTING

SHERLOCK ELECTRO-CHEMICAL AMMONIA REFRIGERANT SENSOR

Please See Electro-Chemical Sensor manual 44-0377 for more information.

External Amber Light and Internal Red LED Status and Trouble Shooting

Amber Light Status

Solution

Off	Sensor is not powered up. Check power. Ensure that the sensor is being powered by 12V DC. Call Genesis Customer Service.
ON Steady	Sensor is powered up. Sensor is operating properly.
ON Flashing	Sensor element needs to be replaced. The sensor will start flashing 40 days before the sensor goes bad. After 40 days the sensor will stop sending a signal to the Sherlock unit and a "SENSOR OPEN" will show on the display.

Red LED Status

Solution

Off	Sensor is not powered up. Check power. Ensure that the sensor is being powered by 12V DC. Call Genesis Customer Service.
ON Steady	Sensor Fault. Call Genesis Customer Service.
ON Flashing	Sensor is powered up. Sensor is operating properly.

Sensor Reading

Solution

Sensor reading shows the presence of gas	Check space with a hand held leak detector for a leak. If no leak, follow the zero calibration instructions. Next move the sensor to another location or swap positions with another sensor. If readings "move" with the sensor, call Genesis Service.
Sensor output indicates a full scale reading	If readings "stay" at original location, check for wiring problems or the presence of gas. Double check signal wire connection.
Sensor output indicates a System Fault	Is ABS in Sherlock control's Calibration menu reading -36? Sensor element needs to be replaced. If the sensor is new follow the calibration procedure and press the reset button inside the sensor
Sensor output indicates an "open circuit"	Check for wiring problems.
Sensor output indicates a "short circuit"	Check wiring. Check for continuity wiring problems. Sensor Element may have malfunctioned. Call Genesis Customer Service.

MAINTENANCE SCHEDULE

It is recommended that Electro-Chemical sensors are zero calibrated every 12 months to insure accuracy. To aid in performing the maintenance schedule, remember to write down the sensor start up date on the front of the sensor. If it is not written down and a problem due to calibration occurs, the Genesis technician may not be able to help and this could void the warranty. These sensors can last an average of 24 months before replacing the sensor element if the maintenance schedule is followed.

Most of the time push button restart of a new sensor and control calibration is all that is needed to re zero the sensor and keep it from false alarming. Measured gas calibration is necessary for testing the accuracy of the sensor and if the sensor fails to pick up a leak or is suspected of being damaged or faulty. Measured gas calibration should also be done when changing out a new sensor element. **WARNING: Use only recommended concentrations of Ammonia. Undiluted or Pure Ammonia sprayed directly on the sensor can damage the sensor element.**

GLOSSARY

ABS	This is the "absolute value" for the sensor also known as the "raw reading" for the sensor.	HFC	"Hydro Fluoro Carbon" This is a class of refrigerants.
ACGIH	"American Conference of Governmental Industrial Hygienists" This organization sets guidelines for occupational exposure for various gases.	LVL 1(2)	"Level 1(2)"
AEL	"Allowable Exposure Limit, refers to a refrigerant's toxicity level. Found on the refrigerant Material Safety Data Sheet. Also, PEL Permissible Exposure Limit.	K1A, K1B, ETC.	"K" denotes alarm, "1" refers to the alarm level (1 or 2) and "A" refers to the relay pole for that alarm level (A or B),
ALL ACCESS MODE	The user has complete access to the menus of the monitor including SYSTEM CONFIG MENU.	KEY, BUTTON	Keypad for menu and data access.
AL, ALM	"Alarm"	IN1(2)	Setback dry contact input (1 or 2). IN1 also activates time schedule.
ALARM DELAY	This feature is designed to minimize false alarms. It means the sensor must see gas levels at or above the setpoint for this period of time.	IN CHANGE MODE	The user can view as well as change the settings, however the critical settings in the SYSTEM CONFIG MENU cannot be changed.
ASHRAE	"American Society of Heating Refrigeration and Electrical Engineers." This organization sets guidelines for buildings and HVAC machine rooms.	LATCH	This feature allows the user to choose whether they would like an alarm condition to be manually reset (latched) or reset automatically (unlatched) when the alarm condition clears. Some Sherlock units do not have this function.
CAL	"Calibrate"	NDIR	"Non-Dispersive Infrared" Sensors also referred to as IR Sensors.
CFC	"Chloro Fluoro Carbon" This is a class of refrigerants.	NH3	"Ammonia Sensor", Chemical Formula for Ammonia.
CHECKSUM	Mathematics summing of all the control firmware locations. Identical firmware chips should have the same CHECKSUM.	OPEN	Sensor reads OPEN when activated but not wired to input "properly".
COMM BAUD RATE	This identifies the speed of the port used in the communications.	OXYGN SNR	"Oxygen Sensor"
COMMUNICATION STATION	- The monitor has remote communication capabilities. The monitors can be linked together. Each monitor in the network must have its own identification that distinguishes itself from other monitors and controls.	SETBACK	This feature allows the sensors to operate under alternate setting under certain circumstances.
CMOS	"Ceramic Metal Oxide Sensor", also referred to as Solid State Sensors.	SPT	"Setpoint"
DLAY	"Delay".	SNR	"Sensor"
DPDT	"Double Pole Double Throw" This is a type of relay with two independent poles. Each pole (common) can be switched from normally closed contact to normally open contact.	SPDT	"Single Pole Double Throw" This is a type of relay with one pole. The pole (common) can be switched between normally open contact and normally closed.
ELECTRO-CHEM	"Electro-Chemical Sensor" Chemical cell sensor used to monitor for oxygen and ammonia.	VIEW ONLY MODE	- The user can view the settings in the menu but cannot make any changes.
FAULT	Used to display when an Electro-Chemical Ammonia sensor needs to be replaced.		
HCFC	"Hydro Chloro Fluoro Carbon" This is a class of refrigerants.		

PARTS LIST

ITEM	PART#	ITEM	PART#
Sherlock 102 Control (SHER102)	82-0339	Regulating Valve, Standard Calibration Kit	46-0003
Sherlock 102 Control NEMA 4X (SHER102-4)	60-0141	Regulating Valve, Ammonia Calibration Kit	46-0010
Sherlock 102 Control With Analog Output (SHER102-A)	82-0375		
Sherlock 202 Control (SHER202)	82-0319	Calibration Kit For R-11 Sensors	88-0221
Sherlock 202 Control With Zone Isolation (SHER202-R)	82-0344	Calibration Kit For R-12 Sensors	88-0286
Sherlock 202 Control With Analog Output (SHER202-A)	82-0380	Calibration Kit For R-22 Sensors	88-0152
Sherlock 202 Control NEMA 4X (SHER202-4)	60-0133	Calibration Kit For R-134A Sensors	88-0153
Optional Strobe Light Factory Mounted on Control (-S)	87-0085	Calibration Kit For R-123 Sensors	88-0154
		Calibration Kit For R-404a Sensors	88-0215
Solid State CMOS CFC/HCFC Sensor	82-0100	Calibration Kit For R-507a Sensors	88-0396
Solid State CMOS CFC/HCFC Sensor NEMA 3R	60-0113	Calibration Kit For Oxygen Deprivation Sensors	88-0155
Solid State CMOS HFC Sensor	82-0101	Calibration Kit For R-717 (NH3) Sensors	88-0156
Solid State CMOS HFC Sensor NEMA 3R	60-0128		
Solid State CMOS Ammonia (NH ₃) Sensor	82-0102	Remote Alarm:	82-0127
Solid State CMOS Ammonia (NH ₃) Sensor NEMA 3R	60-0129	Auto Alarm Dialer Model 1104:	87-0001
Solid State CMOS CFC/HCFC Ventline Sensor	60-0018	Auto Alarm Dialer Model 1108:	87-0008
Solid State CMOS HFC Ventline Sensor	60-0028	Remote Alarm And Strobe:	88-0109
Solid State CMOS Ammonia (NH ₃) Ventline Sensor	60-0027	Horn	87-0030
Solid State High Pressure Ventline Sensor	60-0076	Horn/Strobe	87-0005
		1 Horn/Strobe w/Power Kit:	88-0227
Electrochemical Oxygen Deprivation Sensor	82-0108	2 Horn/Strobes w/Power Kit:	88-0228
Electrochemical Ammonia (NH ₃) Sensor	82-0460	3 Horn/Strobes w/Power Kit:	88-0229
Electrochemical Ammonia (NH ₃) Sensor, Low temp	82-0461	1 Horn/Strobe w/Power Kit:	88-0230
		2 Horn/Strobes w/Power Kit:	88-0231
R-11 Infrared Sensor NEMA 3R 45F to 120F	60-0057	3 Horn/Strobes w/Power Kit:	88-0232
R-12 Infrared Sensor NEMA 3R 45F to 120F	60-0104	1 Horn/Strobe:	88-0233
R-22 Infrared Sensor NEMA 3R 45F to 120F	60-0053	Strobe Light w/Power Kit:	88-0234
R-114 Infrared Sensor NEMA 3R 45F to 120F	82-0260	2 Stacked Beacons with Horn (Red, Amber)	88-0292
R-123 Infrared Sensor NEMA 3R 45F to 120F	60-0137	3 Stacked Beacons with Horn (Red, Amber, Blue)	88-0252
R-134a Infrared Sensor NEMA 3R 45F to 120F	60-0054	Break Glass Pull Station w/Back Box (Blue)	88-0268
R-402a Infrared Sensor NEMA 3R 45F to 120F	82-0249	Break Glass Pull Station w/Back Box (Yellow)	88-0271
R-404a Infrared Sensor NEMA 3R 45F to 120F	60-0052	GenCom Communications Installation Manual	44-0025
R-408a Infrared Sensor NEMA 3R 45F to 120F	60-0065	Gencom Interface Board to Modem	80-0010
R-409a Infrared Sensor NEMA 3R 45F to 120F	60-0066	Gencom Interface Wire Harness	80-0145
R-410a Infrared Sensor NEMA 3R 45F to 120F	60-0165	Gencom to Modem Ribbon Cable – 8”	80-0202
R-500 Infrared Sensor NEMA 3R 45F to 120F	82-0288	“The Stick” FAX Phone Switch	87-0002
R-502 Infrared Sensor NEMA 3R 45F to 120F	60-0059	GenCom Communication:	88-0190
R-507a Infrared Sensor NEMA 3R 45F to 120F	60-0061	GenCom Communication (w/ 33.6 KB Modem)	88-0191
R-717(NH ₃) Infrared Sensor NEMA 3R 45F to 120F	60-0095		
R-11 Infrared Sensor NEMA 3R -30F to 45F	60-0058	Inline Filter	30-0026
R-22 Infrared Sensor NEMA 3R -30F to 45F	60-0047	Transformer, Wall Plug, 12V DC 250ma	33-0008
R-404a Infrared Sensor NEMA 3R -30F to 45F	60-0051	Transformer, Wall Plug, 12V DC 250ma	33-0032
R-408a Infrared Sensor NEMA 3R -30F to 120F	60-0065	Transformer, Wall Plug, 12V DC 1.5a	33-0051
R-502 Infrared Sensor NEMA 3R -30F to 45F	60-0060	Fuse, 3.15 Amp, Time Lag	33-0054
R-507a Infrared Sensor NEMA 3R -30F to 45F	60-0062	Fuse, 6.3 Amp	33-0038
R-717 (NH ₃) Infrared Sensor NEMA 3R -30Fto 45F	60-0096	Sherlock 102 Control Power Supply 24 VAC	33-0025
		Power Supply, Switching, 12V DC 3a	33-0068
Gas Canister, 250 ppm R22, Air Balance, 34L	46-0004	Power Supply, Switching, 12V DC 6.2a	33-0072
Gas Canister, 1000 ppm R22, Air Balance, 34L	46-0024	Housing, Horn Strobe Power Supply w/ Knockouts	35-0075
Gas Canister, 250 ppm R22, Air Balance, 104L	46-0029		
Gas Canister, 250 ppm R134a, Air Balance, 34L	46-0005	Belden #8443 Triad Twisted Sensor Cable 22 AWG	27-0063
Gas Canister, 250 ppm R123, Air Balance, 34L	46-0006	Belden #8770 Triad Twisted Shielded Sensor Cable 18 AWG	27-0094
Gas Canister, 50 ppm R123, Air Balance, 34L	46-0030	Belden #9364 Triad Twisted Shielded Sensor Cable 20 AWG	27-0082
Gas Canister, 250 ppm R-404A, Air Balance, 34L	46-0022	Testing Fluid, Sherlock CFC/HCFC and HFC Sensors	45-0008
Gas Canister, 250 ppm R-507A, Air Balance, 34L	46-0031	Testing Fluid, Sherlock Ammonia Sensors	45-0019
Gas Canister, 250 ppm R11, Air Balance, 34L	46-0011		
Gas Canister, 250 ppm R12, Air Balance, 34L	46-0023	Manual Sherlock 2 SERIES (Obsolete)	44-0093
Gas Canister, 17% Oxygen, Nitrogen Balance, 34L	46-0007	Manual Sherlock 102/202 (SHER102 / SHER202)	44-0297
Gas Canister, 20.9% Oxygen, Nitrogen Balance, 34L	46-0008	Manual Solid State CMOS Refrigerant Gas Sensor	44-0283
Gas Canister, 20.9% Oxygen, Nitrogen Balance, 104L	46-0013	Manual Infrared Refrigerant Gas Sensor (Obsolete)	44-0221
Gas Canister, 50 ppm Ammonia, Air Balance, 75L	46-0027	Manual Infrared Refrigerant Gas Sensor	44-0295
Gas Canister, 250 ppm Ammonia, Air Balance, 75L	46-0026		
Gas Canister, 500 ppm Ammonia, Air Balance, 75L	46-0009		

GENERAL WIRING SCHEMATIC - SHERLOCK SYSTEM

SHERLOCK 102 AND 202 COMPLETE SYSTEM

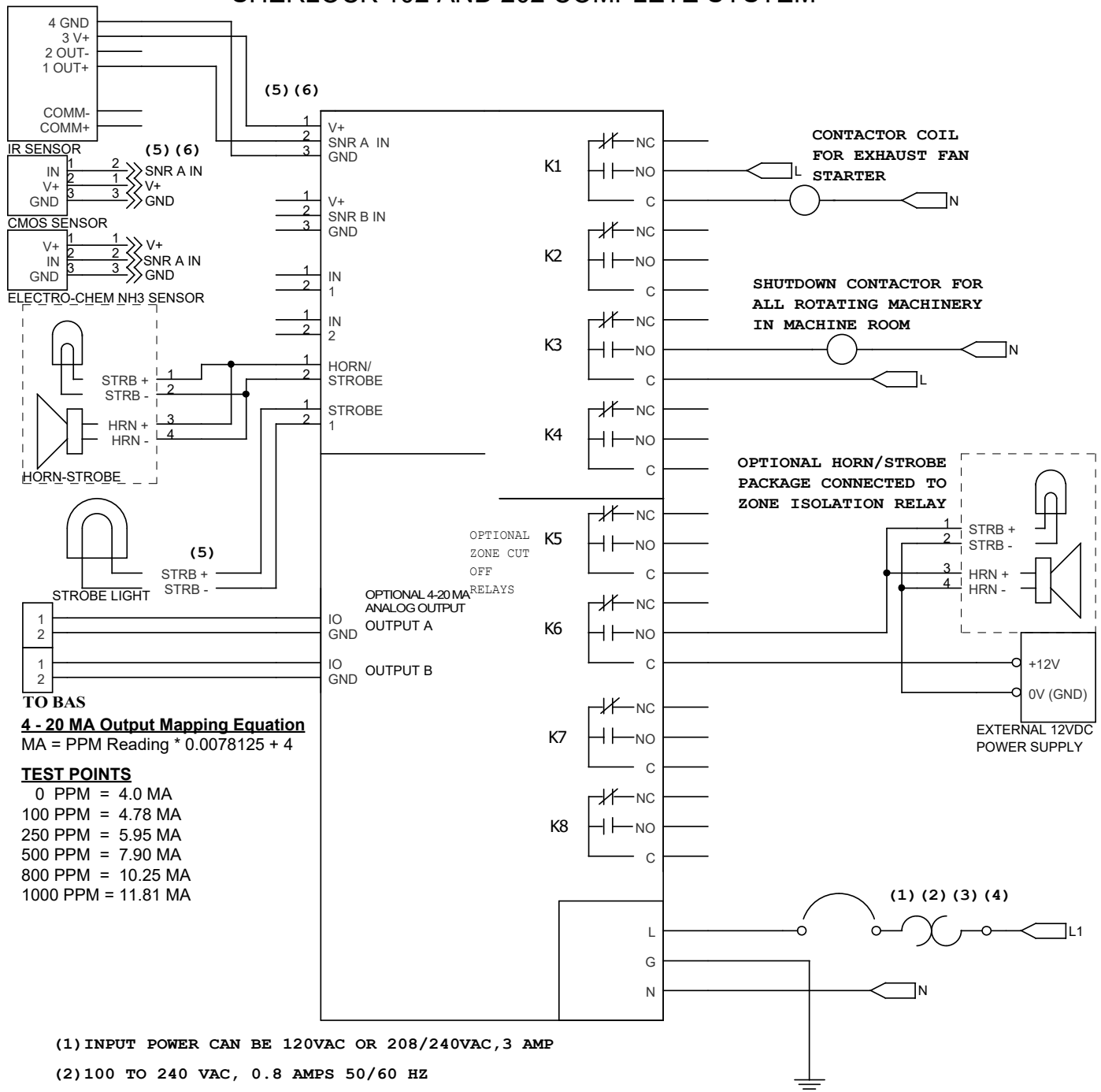

(1) INPUT POWER CAN BE 120VAC OR 208/240VAC, 3 AMP

(2) 100 TO 240 VAC, 0.8 AMPS 50/60 HZ

(3) GROUNDED NEUTRAL

(4) THE SHERLOCK CONTROL SYSTEM IS A PERMANENTLY CONNECTED DEVICE. ENSURE THAT THE CONTROL POWER SOURCE IS WIRED THROUGH AN EXTERNAL ELECTRICAL CUT-OFF SWITCH OR THROUGH A 15AMP CIRCUIT BREAKER. LOCATE THE CUT-OFF SWITCH OR CIRCUIT BREAKER NEAR THE CONTROL UNIT.

(5) TOTAL OUTPUT FROM 12 VDC DEVICES CANNOT EXCEED 3.0 AMPS INCLUDING SENSORS AND ALL ALARM DEVICES

(6) ANY SHERLOCK SENSOR (SOLID STATE (CMOS), INFRARED, ELECTRO-CHEM) CAN BE WIRED TO THE SENSOR A OR SENSOR B INPUT. THE OXYGEN SENSOR MUST BE WIRED TO SENSOR A.

THIS IS A TYPICAL WIRING DIAGRAM FOR REFERENCE ONLY. ACTUAL FIELD WIRING MAY DIFFER SIGNIFICANTLY FROM THIS DRAWING.

PAGE FOR FIELD WIRING - SHERLOCK SYSTEM

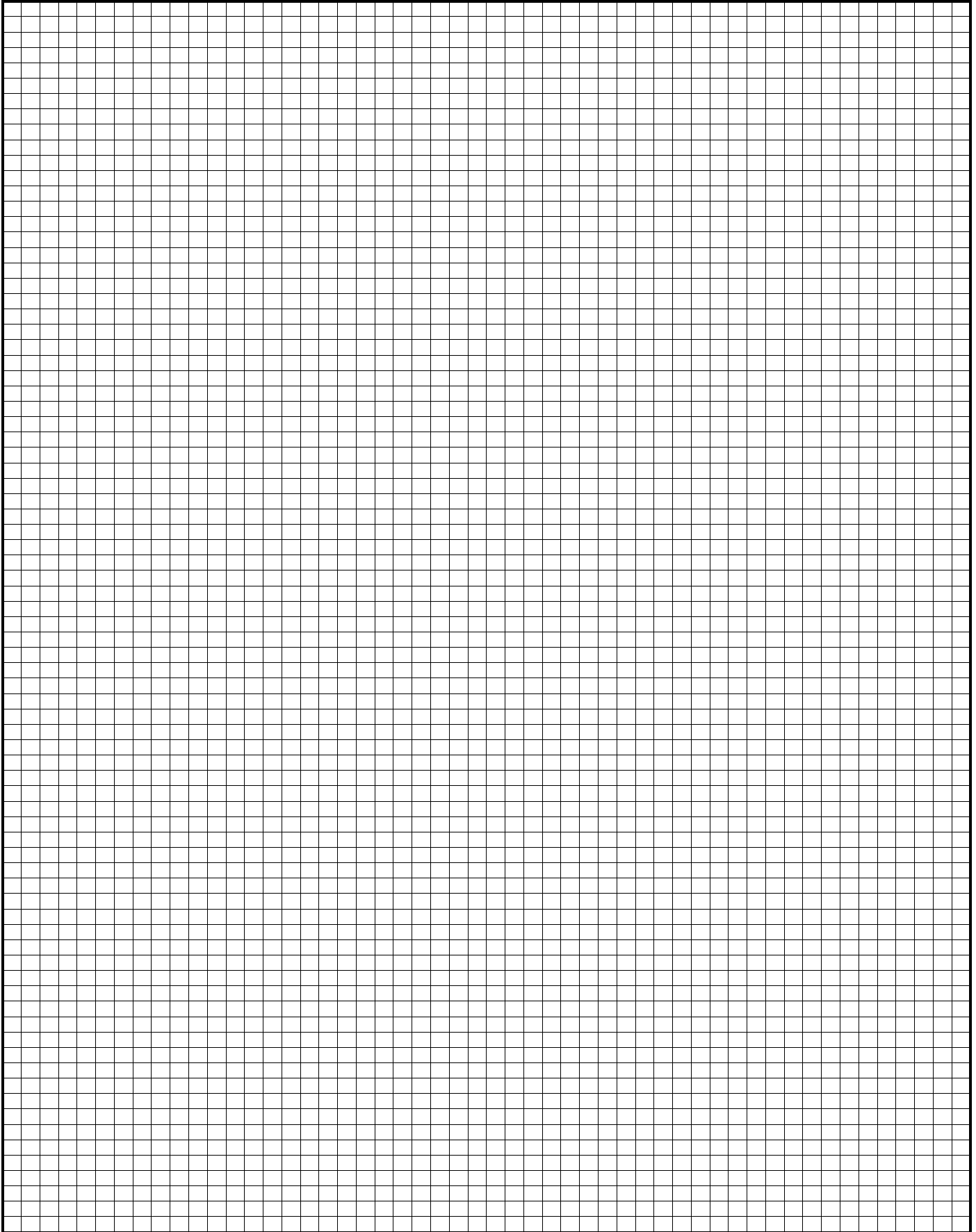

RECOMMENDED SETPOINTS

Before using the table below of "Suggested Setpoints", it must be noted that different municipalities use different standards depending upon local laws. Several Universal codes have published recommended alarm levels

- ASHRAE 15-2010
- Uniform Mechanical Code
- International Mechanical Code
- Standard Mechanical Code

When calculating the setpoints for the Sherlock control, the local code jurisdictions need to be consulted. Some jurisdictions have modified the Universal codes for their specific use. It is also a good idea to consult the refrigerant manufacturers Material Safety Data Sheet (MSDS) for Permissible Exposure Limits (PEL) and Immediate Danger to Life and Health (IDLH) limits.

Alarm levels can also vary depending upon which refrigerant is used. If your refrigerant is not listed, check the manufacturers material safety data sheet for PEL (also Allowable Exposure Limit) (AEL)) and IDLH limits. Generally, safety group A1 refrigerants (R11, R-22, R-134a, R-404a, R-410A, R-507, etc.) have a PEL of 1,000 PPM. Group B1 (R-123) and B2 (Ammonia, NH₃) have a much lower PEL.

The Uniform Mechanical Code table 11-A, from which this table was constructed, which is similar to tables in the other recognized Universal Codes and other code books states alarm levels should be at no more than 50% and 25% of the PEL.

If you have questions or concerns, contact Genesis International technical support and we can guide you further.

Suggested Setpoints

Refrigerant	Uniform Mechanical Code Levels			Sherlock 2-Series	
	PEL (ppm)	IDLH (ppm)	25% LFL (ppm)	Alarm Level 1	Alarm Level 2
R-11	1000	5000	na	250	500
R-12	1000	50000	na	250	500
R-22	1000	50000	na	250	500
R-113	1000	4500	na	250	500
R-114	1000	50000	na	250	500
R-123	30	4000	na	30	200
R-134A	1000	50000	na	250	500
R-500	1000	50000	na	250	500
R-502	1000	50000	na	250	500
R-717 (NH ₃)	50	500	40000	50	250

***Levels taken from Uniform Mechanical Code**

THIS PAGE INTENTIONALLY LEFT BLANK



ONE YEAR LIMITED WARRANTY

GENESIS INTERNATIONAL INC. (GENESIS) WARRANTS EACH NEW ELECTRONIC CONTROL SYSTEM AND COMPONENT PART THEREOF TO BE FREE FROM DEFECTS IN MATERIAL AND WORKMANSHIP AT THE TIME OF PURCHASE. GENESIS' OBLIGATION UNDER THIS WARRANTY SHALL BE LIMITED TO REPAIRING OR EXCHANGING ANY PART OR COMPONENT PARTS THEREOF, WITHOUT CHARGE, F.O.B. FACTORY OR NEAREST AUTHORIZED PARTS DEPOT, WHICH MAY PROVE DEFECTIVE WITHIN ONE (1) YEAR FROM DATE OF ORIGINAL INSTALLATION (NOT TO EXCEED FIFTEEN (15) MONTHS FROM THE DATE OF SHIPMENT FROM THE GENESIS FACTORY) AND WHICH IS PROVEN TO THE SATISFACTION OF GENESIS TO BE DEFECTIVE. GENESIS MAY AT ITS OPTION SHIP A REPLACEMENT PART PRIOR TO RECEIPT OF THE CUSTOMER'S DEFECTIVE PART AND PROOF OF THE DATE OF ORIGINAL INSTALLATION UPON RECEIPT OF A PURCHASE ORDER FROM THE CUSTOMER. UPON RECEIPT BY GENESIS OF A DEFECTIVE PART PROVEN TO GENESIS' SATISFACTION TO BE DEFECTIVE, THE CUSTOMER WILL BE CREDITED THE EXCHANGE PRICE OF THE PART. IF NOT WITHIN THE COVERAGE OF THIS LIMITED WARRANTY, THE PART OR PARTS WILL BE RETURNED TO THE CUSTOMER C.O.D. AND A CHARGE MAY BE IMPOSED FOR A REPAIR COST ESTIMATE. THE WARRANTIES TO REPAIR OR REPLACE ABOVE RECITED ARE THE ONLY WARRANTIES, EXPRESS, IMPLIED OR STATUTORY, MADE BY GENESIS WITH RESPECT TO THE ELECTRONIC CONTROL SYSTEM OR COMPONENT PARTS THEREOF, INCLUDING ANY IMPLIED WARRANTY OF MERCHANTABILITY OR FITNESS FOR A PARTICULAR PURPOSE, AND GENESIS NEITHER ASSUMES NOR AUTHORIZES ANY PERSON TO ASSUME FOR IT, ANY OTHER OBLIGATION OR LIABILITY IN CONNECTION WITH ANY PRODUCT WHICH UTILIZES A GENESIS ELECTRONIC CONTROL SYSTEM. SHIPPING CHARGES FOR WARRANTED ITEMS MAY ALSO APPLY.

WITHIN 30 DAYS OF THE DATE OF SHIPPING GENESIS WILL TAKE BACK ANY UNUSED EQUIPMENT AND REFUND THE CUSTOMER IN FULL MINUS A 15% RESTOCKING FEE AND ANY DAMAGE CHARGES OR TESTING CHARGES. IF THE UNIT IS RETURNED WITHIN 90 DAYS AN IN HOUSE CREDIT WILL BE GIVEN MINUS A 15% RESTOCKING FEE. RETURNS FOR CREDIT WILL NOT BE GIVEN AFTER 90 DAYS FROM THE SHIP DATE.

THIS WARRANTY SHALL NOT APPLY TO LOSS OF FOOD OR REFRIGERANT GAS, OR INCREASED POWER CONSUMPTION OR INCREASED UTILITY CHARGES DUE TO FAILURE FOR ANY REASON.

GENESIS SHALL NOT BE LIABLE FOR ANY LOSS, CLAIM, INJURY OR DAMAGE TO ANY PERSON OR PROPERTY, OR LOST PROFITS OR OTHER SIMILAR LOSS, OR DAMAGE, WHICH MAY ARISE, DIRECTLY OR INDIRECTLY, RESULT OR BE CLAIMED TO HAVE RESULTED FROM A DEFECT IN THE WORKMANSHIP OR MATERIALS OF ANY PRODUCT WHICH UTILIZES THE GENESIS ELECTRONIC CONTROL SYSTEM OR ANY COMPONENT PART THEREOF.

GENESIS SHALL NOT BE LIABLE FOR ANY LOSSES OR DAMAGES 1) RESULTING FROM ANY REPAIRS OR REPLACEMENTS MADE BY THE CUSTOMER TO THE GENESIS ELECTRONIC CONTROL SYSTEM OR ANY COMPONENT PART THEREOF WITHOUT THE WRITTEN CONSENT OF GENESIS, OR 2) WHEN THE ELECTRONIC SYSTEM IS INSTALLED OR OPERATED IN A MANNER CONTRARY TO THE PRINTED INSTRUCTIONS COVERING INSTALLATION AND SERVICE WHICH ACCOMPANIED THE SYSTEM. FURTHERMORE, GENESIS SHALL NOT BE LIABLE FOR PAYMENT OF ANY REMOVAL OR INSTALLATION CHARGES OF WARRANTED PARTS.

GENESIS SHALL NOT BE LIABLE FOR ANY DAMAGES, DELAYS, OR LOSSES CAUSED BY DEFECTS, NOR FOR DAMAGES CAUSED BY SHORT OR REDUCED SUPPLY OF MATERIALS, FIRE, FLOOD, STRIKES, ACTS OF GOD, OR CIRCUMSTANCES BEYOND ITS CONTROL OR WHEN THE FAILURE OR DEFECT OF ANY PART OR COMPONENT PARTS OF THE SYSTEM IS INCIDENT TO ORDINARY WEAR, ACCIDENT, ABUSE OR MISUSE, OR WHEN THE SERIAL NUMBER OF THE SYSTEM OR COMPONENT PART HAS BEEN REMOVED, DEFACED, ALTERED, OR TAMPERED WITH.

THIS WARRANTY SHALL BE VOID WHEN THIS ELECTRONIC CONTROL SYSTEM OR ANY COMPONENT PART THEREOF IS OPERATED ON HIGH, LOW, IMPROPER VOLTAGE OR AMPERAGE, PUT TO A USE OTHER THAN NORMALLY RECOMMENDED BY GENESIS, MOVED TO A DIFFERENT ADDRESS OTHER THAN THE ORIGINAL INSTALLATION, OR TRANSFERRED TO A SECOND OWNER.

THE WARRANTY OF ITEMS RESOLD BY GENESIS AND WARRANTED BY THE ORIGINAL MANUFACTURER SHALL BE TRANSFERRED TO THE ORIGINAL OWNER AND WILL BE THE ONLY WARRANTY RECOGNIZED BY GENESIS.



GENESIS INTERNATIONAL, INC.

**1040 FOX CHASE INDUSTRIAL DRIVE
ARNOLD, MISSOURI 63010**

**PHONE: (636) 282-0011
FAX: (636) 282-2722**

**WEBSITE:
WWW.GENESIS-INTERNATIONAL.COM**

**EMAIL:
MAIL@GENESIS-INTERNATIONAL.COM**