



# SM998/SM999 Universal Refrigeration Evaporator Motor

1. (2) Rubber Grommets
2. (2) Wire Nuts
3. (1) Hub Adapter
4. (1) Shaft Adapter
5. (4) Pin Standoffs
6. (2) 6-32 X 7/8" Threaded Rods
7. (2) 6-32 X 11/16" Phillip Screws
8. (2) 6-32 X 13/16" Phillip Screws
9. (4) Self Tapping Screws
10. (2) Hex Nuts
11. (4) Post Standoffs
12. (4) 10-32 X 3/8" Slotted Screws
13. (1) Motor Enclosure

SM998 Motors are single speed 240 V. 50/60 Hz.

SM999 Motors are single speed 120 V. 50/60 Hz.

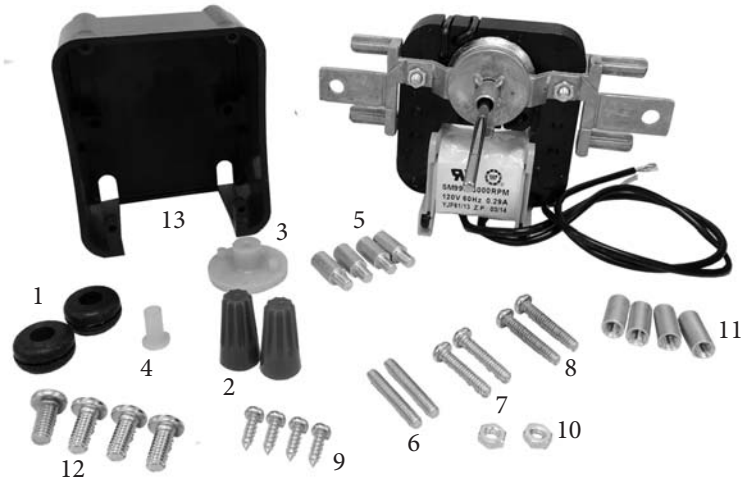

**Important: Disconnect source of electrical supply to prevent electrical shock hazard.**

## Original Motor Removal

1. Disconnect motor lead wires. Cut wires close to the motor if wired direct. If the motor is connected with quick connect terminals, cut the terminals off and discard them. If the original motor has leads that plug into a harness, cut the wires between the motor and the plug(s).
2. Remove the original motor from the unit, and save the hardware to install the replacement motor. Retain the defective motor as a model for the replacement motor.
3. Remove the fan blade from the original motor and save to install on the replacement motor.

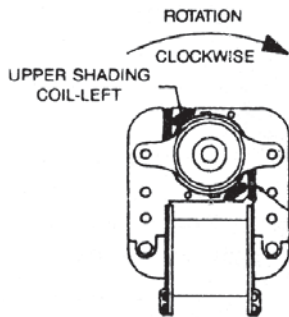
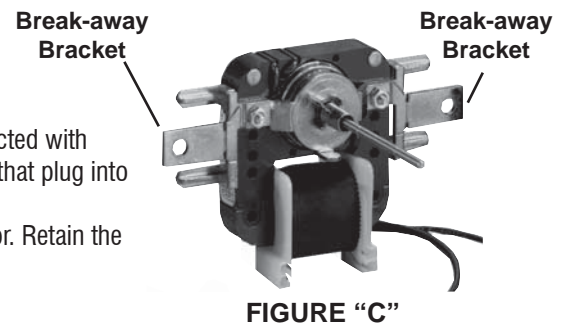

**FIGURE "A"**

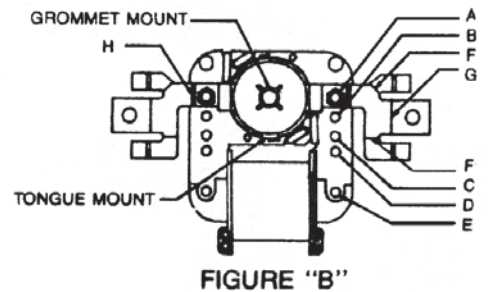
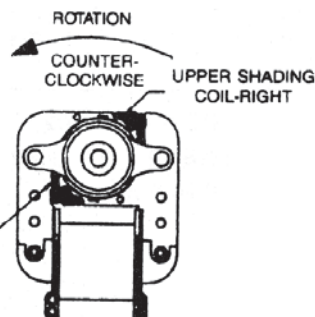

## Installation

1. Determine the motor rotation by referring to figure "A". The new motor is furnished with clockwise rotation when facing the shaft extension end.
2. To reverse the rotation, remove the screws holding the front and rear bearing brackets. Remove the front bearing bracket, lift shaft and rotor out and reverse. (Make sure front and rear thrust washers are in proper position.) Install screws and secure with hex nuts.
3. Determine if the shaft length needs to be shortened to meet the original shaft length. The motor is provided with two break-away points on the shaft. Choose the length which is closest to the original motor.
4. Use the following procedure to shorten the shaft without damaging the motor. With the motor resting on a solid surface, grip the shaft with a pair of pliers on each side of the break-away area. Hold the pliers closest to the motor firm while moving the other pair until the shaft breaks.
5. The new motor is also supplied with a break-away bracket design, which will accommodate most of the mounting configurations shown below. In most instances portions of the bearing brackets will have to be broken off in order to meet the mounting requirements of the original motor. This again must be done using two pairs of pliers to insure that the bracket only breaks where required. Grip bracket on each side of the break-away groove holding the pliers firm on the portion you want to keep. See figure "C".  
When removing the tongue mounts grasp the motor firmly with your hand and the tongue with a pair of pliers. Be careful not to hit the shaft during the removal process.  
To remove the grommet mounts hold the motor in one hand and using a pair of sidecutters, clip off the four posts that attach the "snoot" to the bearing bracket as low as possible.
6. Select from the assembly instructions the correct mounting configuration for your application.
7. Attach the original fan blade to the motor.
8. Install the replacement motor into the unit.
9. Carefully route the lead wires, making certain that they cannot be hit by the fan blade. Splice the wires using the supplied wire nuts.
10. Restore power, check that the motor is functioning properly, and that the lead wires cannot be hit by the blade.

**SEALED UNIT PARTS CO., INC.**

P.O. Box 21, 2230 Landmark Place

Allenwood, N.J. 08720 USA

www.supco.com

## Assembled SUPCO Motor

## Parts Required

## Procedure

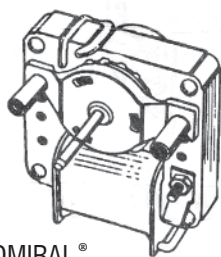

ADMIRAL<sup>®</sup>  
2 Post Standoff Mount

- (2) Post Standoffs
- (2) 10-32 X 3/8" Slotted Screws
- (1) 3/16" Shaft Adapter

1. Shorten shaft
2. Break-away brackets at location "H"
3. Clip-off grommet mounts
4. Replace the hex nuts at location "A" with the standoffs
5. Install the shaft adapter into the fan blade and slide on the shaft.
6. Mount with 10-32 slotted screws.

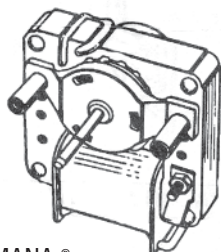

AMANA<sup>®</sup>  
2 Post Standoff Mount

- (2) Post Standoffs
- (2) 6-32 X 11/16" Phillips Screws
- (2) 10-32 X 3/8" Slotted Screws

1. Reverse rotation
2. Shorten shaft
3. Break-away brackets at location "H"
4. Clip-off grommet mounts
5. Install standoffs at location "B" on the shaft side
6. Mount with 10-32 slotted screws

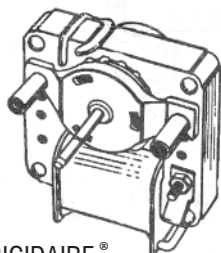

FRIGIDAIRE<sup>®</sup>  
Pin Standoff Mount

- (4) Pin Standoffs
- (2) 6-32 X 7/8" Threaded Rods
- (1) Hub Adapter

1. Shorten Shaft
2. Break-away brackets at location "H"
3. Break-away tongue mounts
4. Clip-off grommet mounts
5. Install pin mounts at location "B" using threaded rod.
6. Install hub adapter on shaft

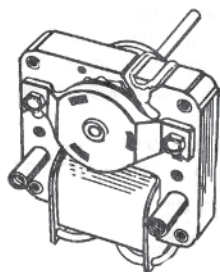

FRIGIDAIRE<sup>®</sup>  
2 Post Standoff Mount

- (2) Post Standoffs
- (2) 6-32 X 11/16" Phillips Screws
- (2) 10-32 X 3/8" Slotted Screws
- (1) Hub Adapter

1. Shorten shaft
2. Break-away brackets at location "H".
3. Break-away tongue mounts
4. Clip-off grommet mounts
5. Install standoffs at location "B"
6. Install hub adapter on shaft

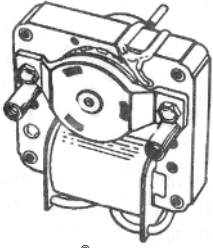
**Assembled SUPCO Motor****Parts Required****Procedure**

FRIGIDAIRE® • WHIRLPOOL®  
Motor Enclosure Mount

- (1) Motor Enclosure
- (2) 6-32 X 11/16" Phillips Screws
- (1) Hub Adapter
- (4) Self Tapping Screws

1. Shorten shaft
2. Break-away brackets at location "H"
3. Break-away tongue mounts
4. Clip-off grommet mounts
5. Insert motor into enclosure and secure with Phillips screws at location "C".
6. Install hub adapter on shaft.
7. Install motor enclosure to plate using self tapping screws

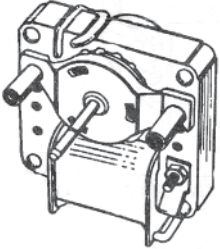

GE® • FRIGIDAIRE®  
KELVINATOR® • GIBSON®  
Grommet Mount

- (2) Rubber Grommets
- (1) 3/16" Shaft Adapter  
(Frigidaire Only)

1. Shorten shaft
2. Break-away brackets at location "H"
3. Install with rubber grommets.

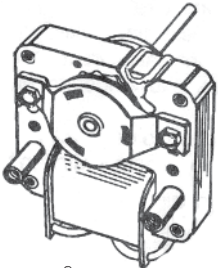

GIBSON® • WHIRLPOOL® • FRANKLIN®  
2 Post Standoff Mount

- (2) Post Standoffs
- (2) 6-32 X 11/16" Phillip Screws
- (2) 10-32 X 3/8" Slotted Screws
- (1) Hub Adapter  
(Franklin Only)

1. Shorten Shaft
2. Break-away brackets at location "H"
3. Break-away tongue mounts
4. Clip-off grommet mounts
5. Install pin mounts at location "B" using threaded rod.
6. Install hub adapter on shaft

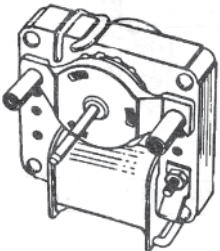

WESTINGHOUSE®  
Tongue Mount

NONE

1. Shorten shaft
2. Break-away brackets at location "H".
3. Break-away tongue mounts
4. Clip-off grommet mounts
5. Install standoffs at location "D" on rear of motor  
(Note: On Franklin reverse rotation, install standoffs at location "B" on rear of motor. Install hub adapter.)
6. Mount with 10-32 slotted screws

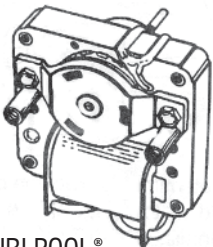

WHIRLPOOL®  
Side Wing Mount

- (1) Hub Adapter

1. Reverse rotation
2. Shorten shaft
3. Break-away brackets at location "G"
4. Clip-off grommet mounts
5. Install hub adapter on shaft

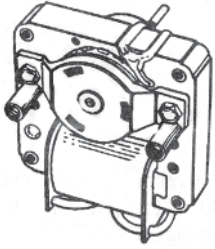
**Assembled SUPCO Motor****Parts Required****Procedure**

WHIRLPOOL<sup>®</sup>  
Side Mount

(1) Hub Adapter

1. Shorten shaft
2. Break-away brackets at location "F" four places
3. Clip-off grommet mounts
4. Install hub adapter on shaft.

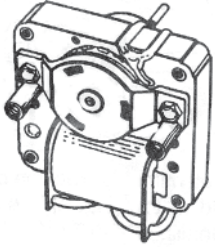

PHILCO<sup>®</sup>  
2 Post Standoff Mount

(2) Post Standoffs  
(2) 6-32 X 11/16" Phillips Screws  
(2) 10-32 X 3/8" Slotted Screws  
(1) Hub Adapter

1. Reverse rotation
2. Shorten shaft
3. Break-away brackets at location "H"
4. Break-away tongue mounts
5. Clip-off grommet mounts
6. Install standoffs at location "C" shaft side.
7. Install hub adapter
8. Install with 10-32 slotted screws.

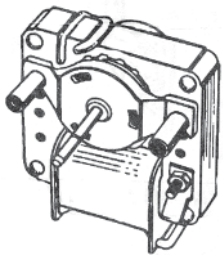

PHILCO<sup>®</sup>  
Screw Mount

(2) 6-32 X 13/16" Phillip Screws  
(2) Hex Nuts

1. Reverse rotation
2. Shorten shaft
3. Break-away brackets at location "H"
4. Break-away tongue mounts
5. Clip-off grommet mounts
6. Install 13/16" screws at location "E" and secure with hex nuts on shaft side
7. Remove hex nuts at location "A" leaving screws on shaft side for mounting

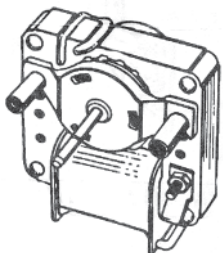

PHILCO<sup>®</sup>  
4 Post Standoff Mount

(4) Post Standoffs  
(2) 6-32 X 13/16" Phillips Screws  
(2) Hex Nuts  
(1) Hub Adapter  
(4) 10-32 X 3/8" Slotted Screws

1. Reverse rotation
2. Shorten shaft
3. Break-away brackets at location "H"
4. Break-away tongue mounts
5. Clip-off grommet mounts
6. Replace hex nuts at location "A" with standoffs
7. Install 13/16" screws at location "E" and secure with hex nuts on shaft side.
8. Install standoffs at locations "E" (on top of nut)
9. Install hub adapter
10. Mount with 10-32 slotted screws



**SEALED UNIT PARTS CO., INC.**

P.O. Box 21, 2230 Landmark Place

Allenwood, N.J. 08720 USA

www.supco.com

Rev. 1222014