

UNIT CURBS ACCOMMODATE AIR CONDITIONING UNIT WITH A TOLERANCE OF NOT MORE THAN 1/8 INCH.

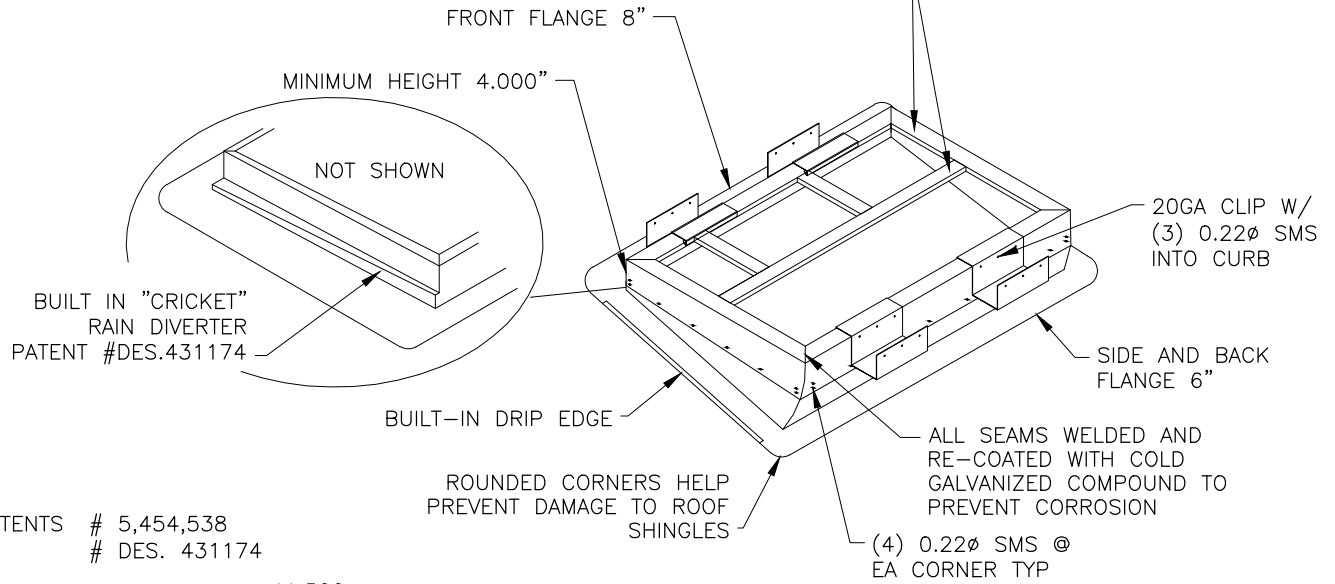

PATENTS # 5,454,538  
# DES. 431174

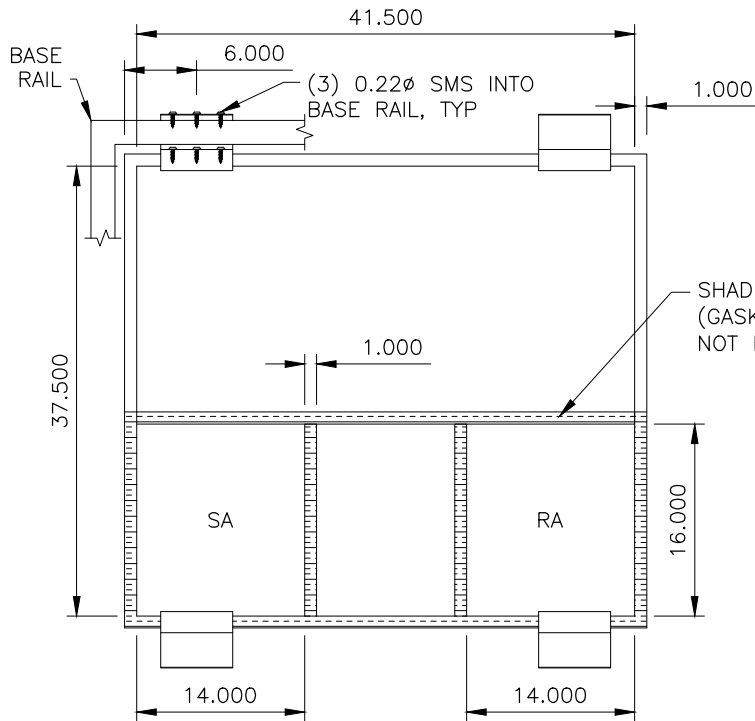

CURB CONSTRUCTION :  
20 GA. G-90 GALVANIZED STEEL FULLY WELDED SEAMS AND CORNERS  
ADJUSTABLE FROM A 2/12 UP TO A 6/12 PITCH  
MAXIMUM LOAD RATING 800 lbs.

PRODUCT #: MSMP1DL

# UNI-PRODUCTS, INC.

3315 Elkhorn Blvd  
North Highlands, CA 95660  
(916)-348-3800  
www.adaptacurb.com  
Mark@adaptacurb.com

DATE: 12/8/2015

**DESIGN CRITERIA**

WIND: 155 MPH, EXP C, ROOF HEIGHT < 60ft lw=1.0  
SEISMIC: Ss=3.73 Ip=1.5  
CODE: 2013 CBC

