

UNIT CURBS ACCOMMODATE AIR CONDITIONING UNIT WITH A TOLERANCE OF NOT MORE THAN 1/8 INCH.

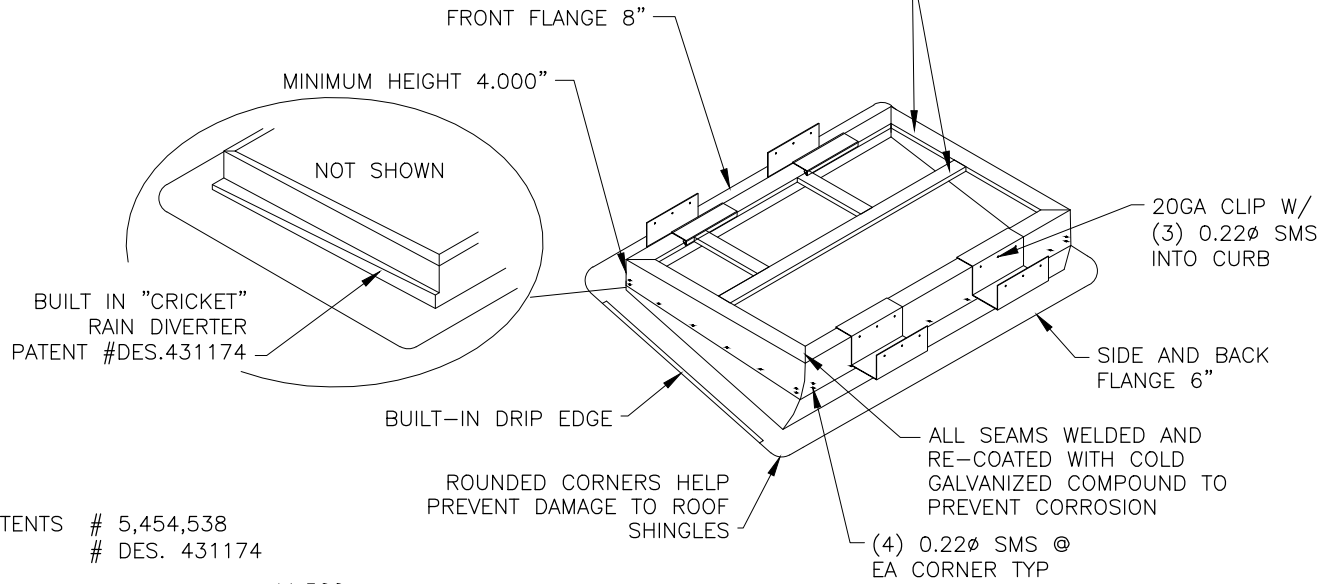

CURB CONSTRUCTION :
20 GA. G-90 GALVANIZED STEEL FULLY WELDED SEAMS AND CORNERS
ADJUSTABLE FROM A 2/12 UP TO A 6/12 PITCH
MAXIMUM LOAD RATING 800 lbs.

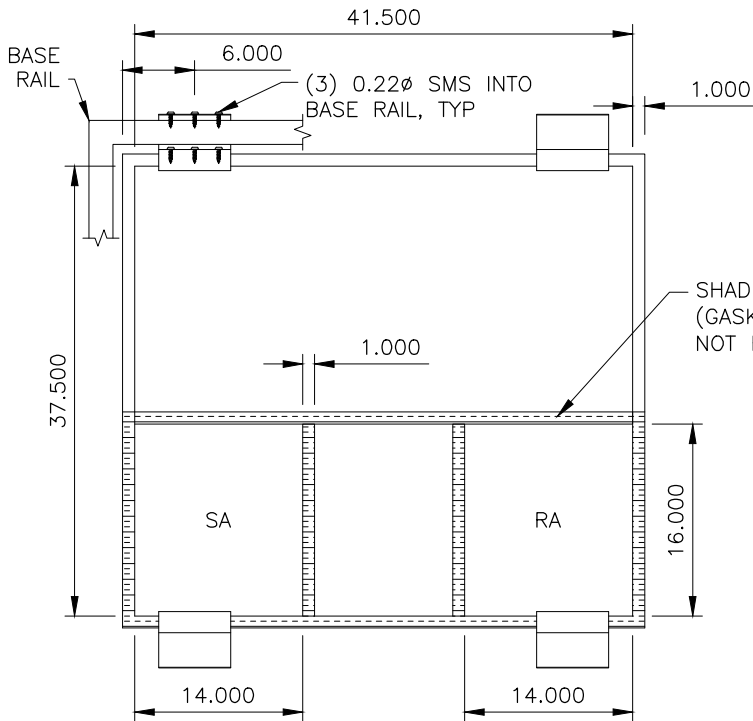

PRODUCT #: MSMP1DL

UNI-PRODUCTS, INC.

3315 Elkhorn Blvd
North Highlands, CA 95660
(916)-348-3800
www.adaptacurb.com
Mark@adaptacurb.com

DATE: 12/8/2015

DESIGN CRITERIA

WIND: 155 MPH, EXP C, ROOF HEIGHT < 60ft lw=1.0
SEISMIC: Ss=3.73 IP=1.5
CODE: 2013 CBC

Weight: 62 lbs"

